

LCP63





Unità di centraggio pneumatica,
singola asta



L	C	P	6	3	0	5	0	K	A	E	R
1	2	3	4		5	6	7	8			

1 Serie	2 Versione	3 Taglia
LC = Unità di centraggio	P = Pneumatica, singola asta	63 = Ø 63 mm

4 Corse	5 Sensore di posizione	6 Terminale asta
015 = 15 mm 025 = 25 mm 040 = 40 mm 050 = 50 mm 060 = 60 mm	D = Sensore pneumatico N = Senza sensore (con piastra di chiusura) K = Sensore elettronico PNP (ottico) (DF-K)	A = Asta per centraggi dislocati B = Asta con impronta a chiavetta C = Asta con impronta a chiavetta a croce, Ø interno 16 mm D = Asta per centraggi dislocati con fori spina maggiorati E = Asta con impronta chiavetta a croce, Ø interno 10 mm F = Asta con sede fissaggio laterale H = Asta con terminale piatto, Ø interno 10 mm I = Asta con terminale piatto, Ø interno 12 mm L = Asta con foro Ø 12 compatibile con CNOMO LCG M = Asta con foro Ø 20 compatibile con CNOMO LCG

7 Orientamento asta	8 Opzione
E = est, standard  O = ovest  N = nord  S = sud 	R = Raschiastelo metallico B = Doppia guida interna e raschiastelo metallico

Solo con terminale asta A o D

LCP63__ _KA_R

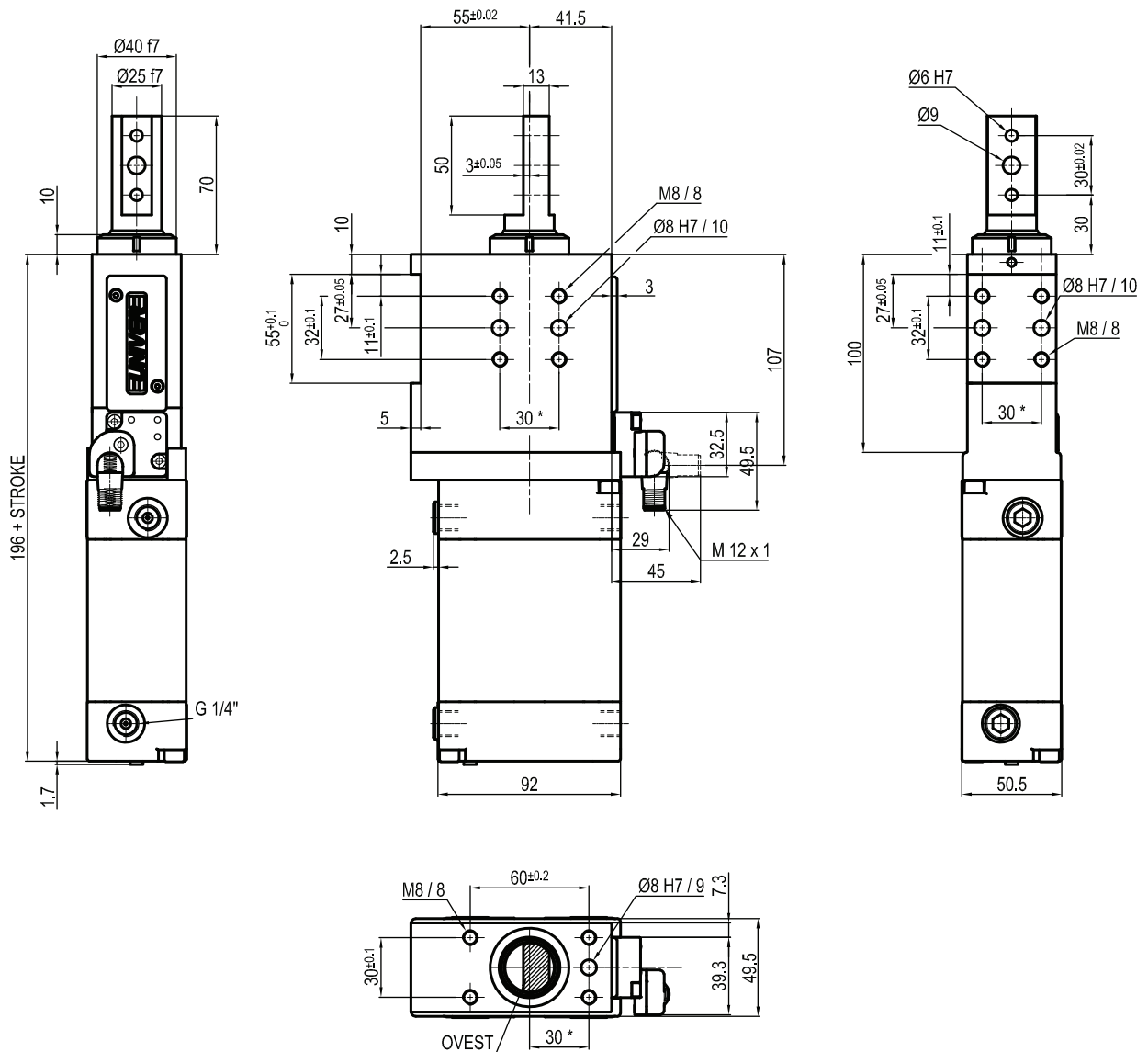

Bore \varnothing	Max. pull force 0,5 MPa	Max. push force 0,5 MPa	Max. torque 6 Nm	Max. deflection moment 7,5 Nm	Weight
63 mm	860 N	960 N	$\pm 0,06^\circ$	$\pm 0,03^\circ$	3,4

 Min./Max. operating pressure: **0,4 / 0,6 MPa**

 Operating temperature: **5° ± 45° C**

 Strokes in mm.: **15 - 25 - 40 - 50 - 60**

Electronic sensor with M12 swivel connector, from 0° to 90°

Supply voltage: 10 ÷ 30 Vdc

 IP code: **IP 65**

Pneumatic ports on both sides

 * : TOLERANCE BETWEEN DOWELS $\pm 0,02$, BETWEEN SCREW HOLES $\pm 0,1$

Subject to technical modifications without notice

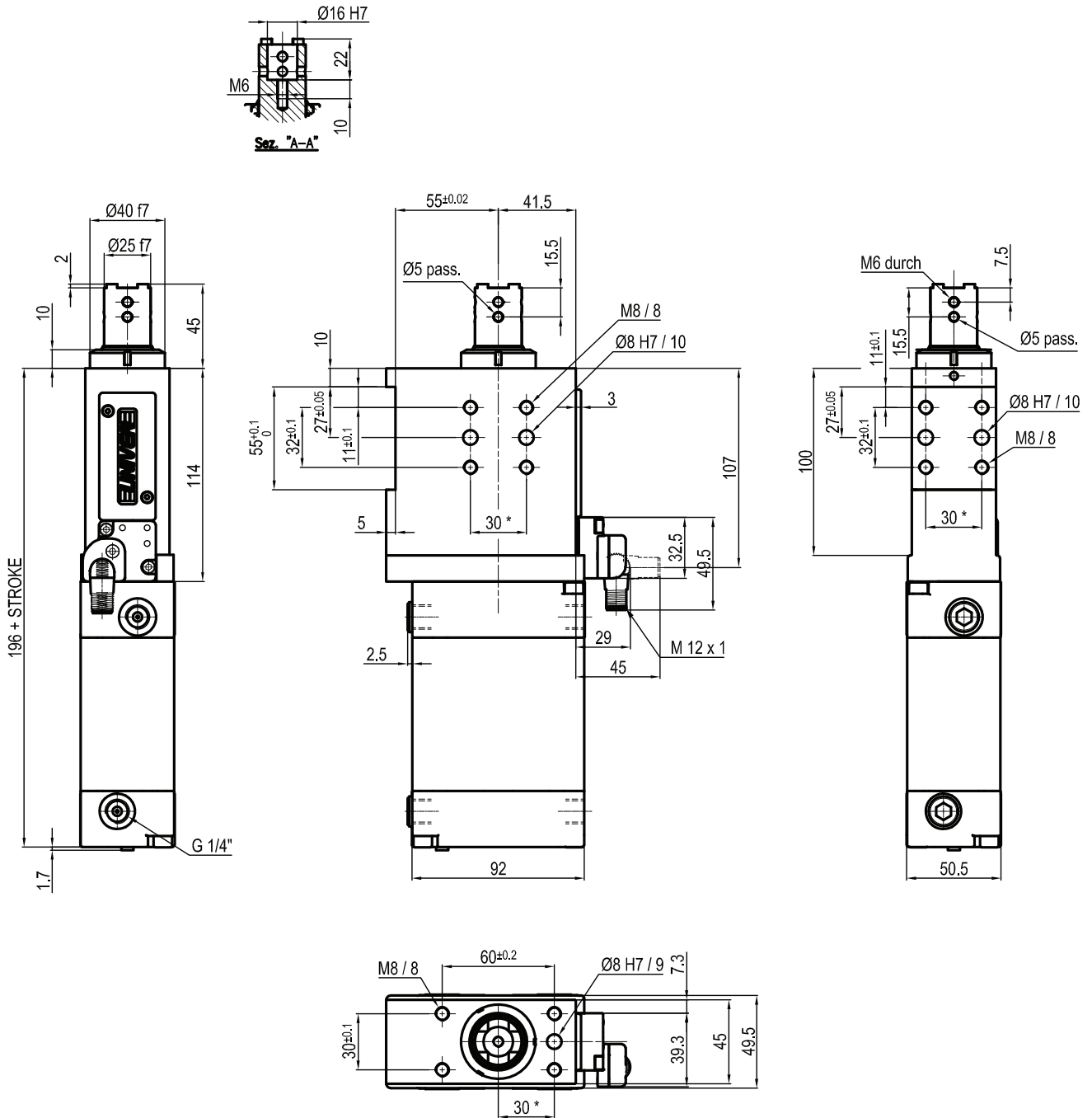
LCP63_ _ _KCR

Bore Ø	Max. pull force 0,5 MPa	Max. push force 0,5 MPa	Max. torque 6 Nm	Max. deflection moment 7,5 Nm	Weight
63 mm	860 N	960 N	± 0,06°	± 0,03°	3,4 Kg

 Min./Max. operating pressure: **0,4 / 0,6 MPa**

 Operating temperature: **5° ± 45° C**

 Strokes in mm.: **15 - 25 - 40 - 50 - 60**

Electronic sensor with M12 swivel connector, from 0° to 90°

Supply voltage: 10 ÷ 30 Vdc

 IP code: **IP 65**

Pneumatic ports on both sides

* : TOLERANCE BETWEEN DOWELS ± 0,02, BETWEEN SCREW HOLES ± 0,1

Subject to technical modifications without notice

LCP63__ _KD_R

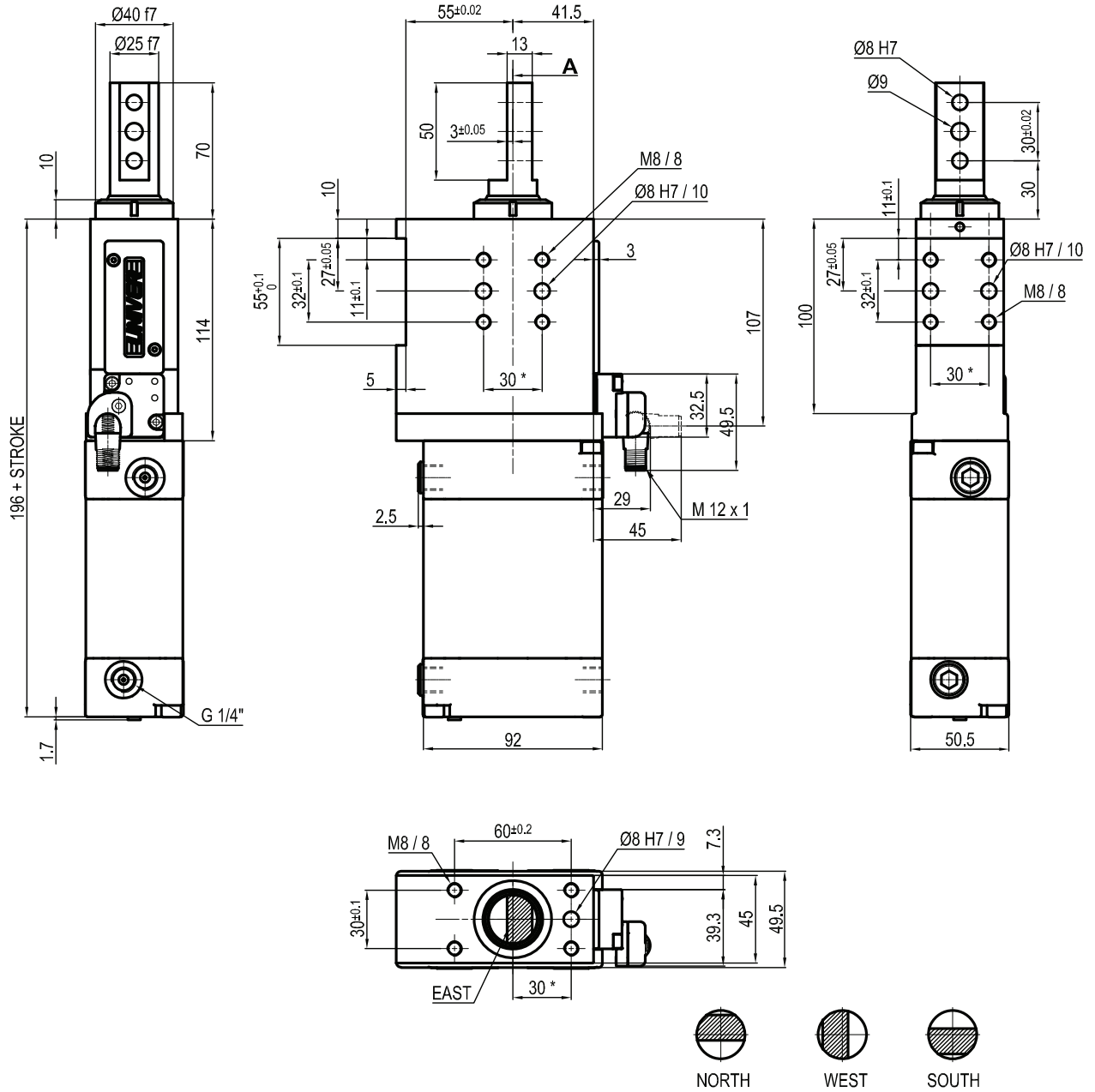

Bore \varnothing	Max. pull force 0,5 MPa	Max. push force 0,5 MPa	Max. torque 6 Nm	Max. deflection moment 7,5 Nm	Weight
63 mm	860 N	960 N	± 0,06°	± 0,03°	3,4 Kg

Min./Max. operating pressure: **0,4 / 0,6 MPa**
 Operating temperature: **5° ± 45° C**
 Strokes in mm.: **15 - 25 - 40 - 50 - 60**
 Electronic sensor with M12 swivel connector, from 0° to 90°
 Supply voltage: 10 ÷ 30 Vdc
 IP code: **IP 65**
 Pneumatic ports on both sides

* : TOLERANCE BETWEEN DOWELS ± 0,02, BETWEEN SCREW HOLES ± 0,1

Subject to technical modifications without notice

LCP63_ _ _KER

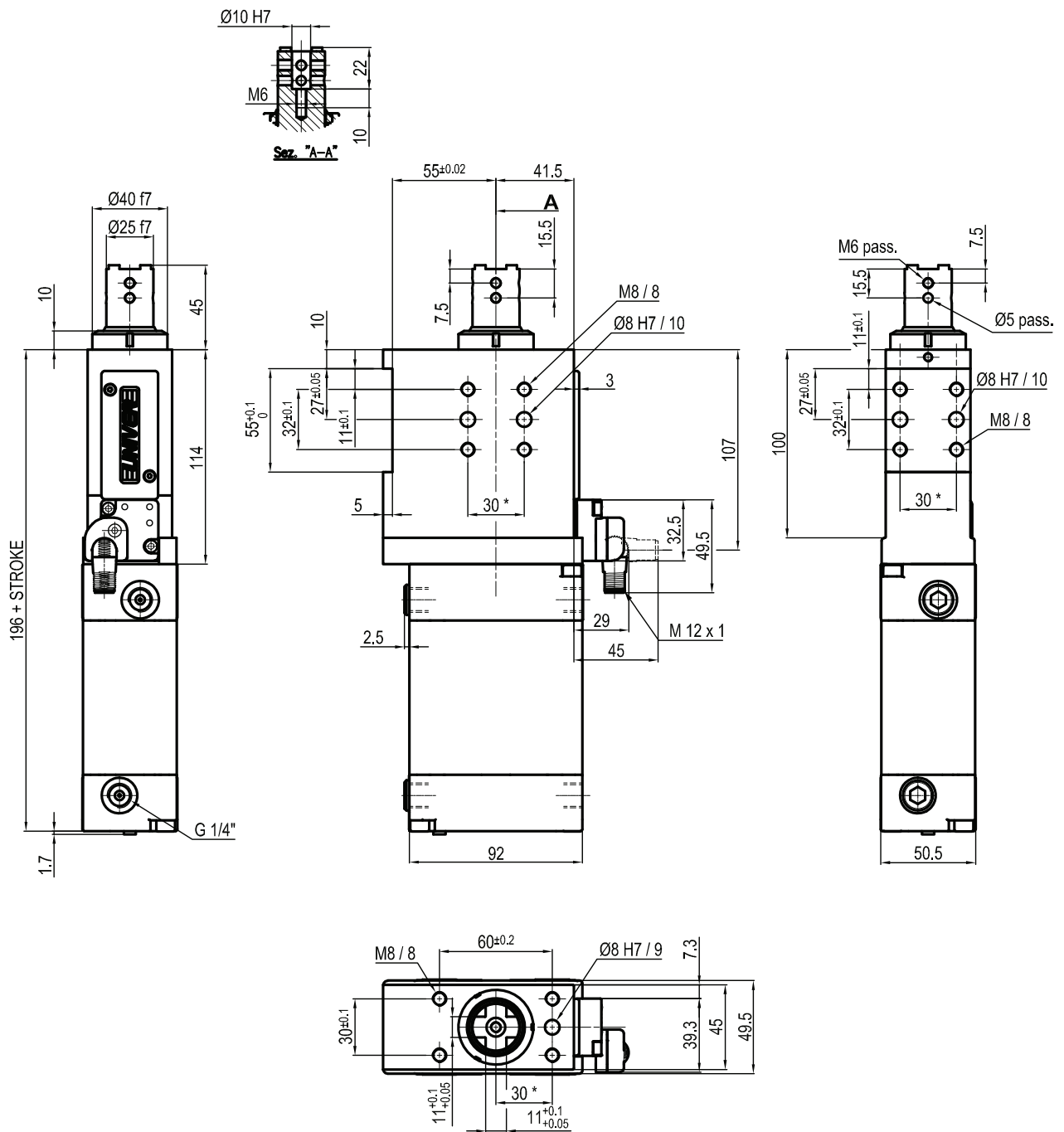

Bore \varnothing	Max. pull force 0,5 MPa	Max. push force 0,5 MPa	Max. torque 6 Nm	Max. deflection moment 7,5 Nm	Weight
63 mm	860 N	960 N	$\pm 0,06^\circ$	$\pm 0,03^\circ$	3,4 Kg

Min./Max. operating pressure: **0,4 / 0,6 MPa**
 Operating temperature: **5° ± 45° C**
 Strokes in mm.: **15 - 25 - 40 - 50 - 60**
 Electronic sensor with M12 swivel connector, from 0° to 90°
 Supply voltage: 10 ÷ 30 Vdc
 IP code: **IP 65**
 Pneumatic ports on both sides

* : TOLERANCE BETWEEN DOWELS $\pm 0,02$, BETWEEN SCREW HOLES $\pm 0,1$

Subject to technical modifications without notice

LCP63_ _ _KFR

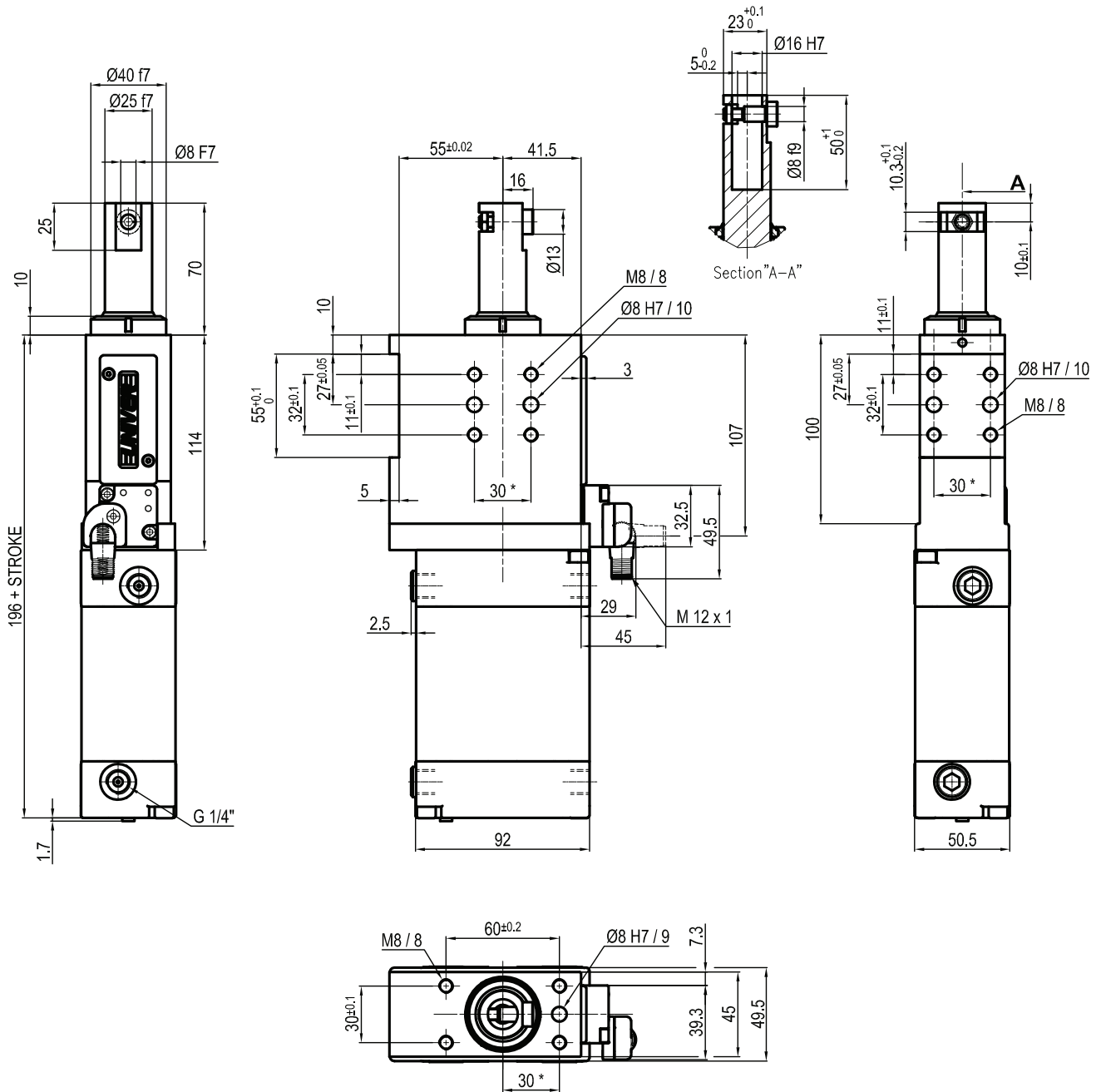

Bore Ø	Max. pull force 0,5 MPa	Max. push force 0,5 MPa	Max. torque 6 Nm	Max. deflection moment 7,5 Nm	Weight
63 mm	860 N	960 N	± 0,06°	± 0,03°	3,4 Kg

Min./Max. operating pressure: **0,4 / 0,6 MPa**
 Operating temperature: **5° ± 45° C**
 Strokes in mm.: **15 - 25 - 40 - 50 - 60**
 Electronic sensor with M12 swivel connector, from 0° to 90°
 Supply voltage: 10 ÷ 30 Vdc
 IP code: **IP 65**
 Pneumatic ports on both sides

* : TOLERANCE BETWEEN DOWELS ± 0,02, BETWEEN SCREW HOLES ± 0,1

Subject to technical modifications without notice

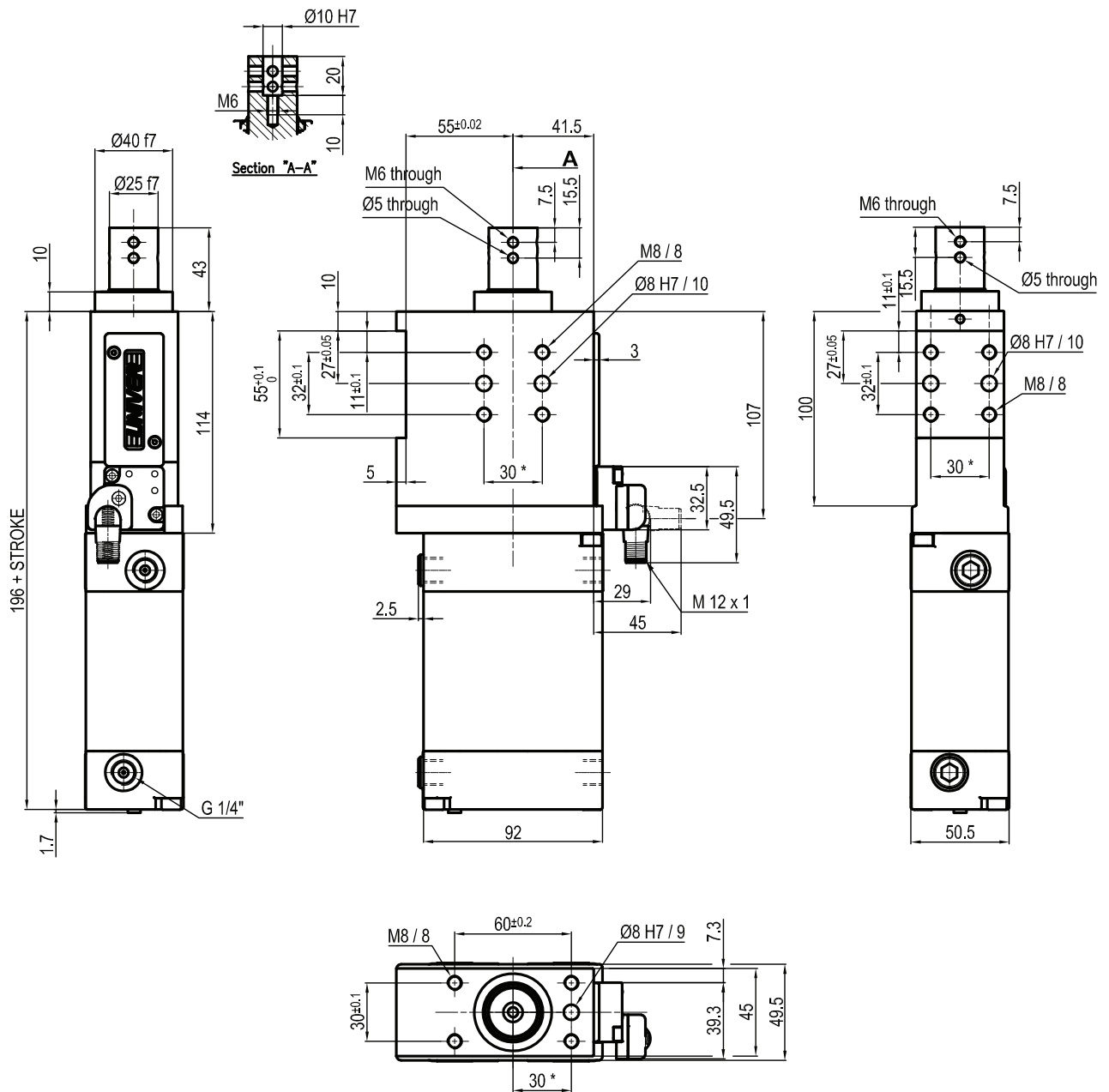
LCP63_ _ _KHR

Bore Ø	Max. pull force 0,5 MPa	Max. push force 0,5 MPa	Max. torque 6 Nm	Max. deflection moment 7,5 Nm	Weight
63 mm	860 N	960 N	± 0,06°	± 0,03°	3,4 Kg

Min./Max. operating pressure: **0,4 / 0,6 MPa**
 Operating temperature: **5° ± 45° C**
 Strokes in mm.: **15 - 25 - 40 - 50 - 60**
 Electronic sensor with M12 swivel connector, from 0° to 90°
 Supply voltage: 10 ÷ 30 Vdc
 IP code: **IP 65**
 Pneumatic ports on both sides

* : TOLERANCE BETWEEN DOWELS ± 0,02, BETWEEN SCREW HOLES ± 0,1

Subject to technical modifications without notice

LCP63__KIR

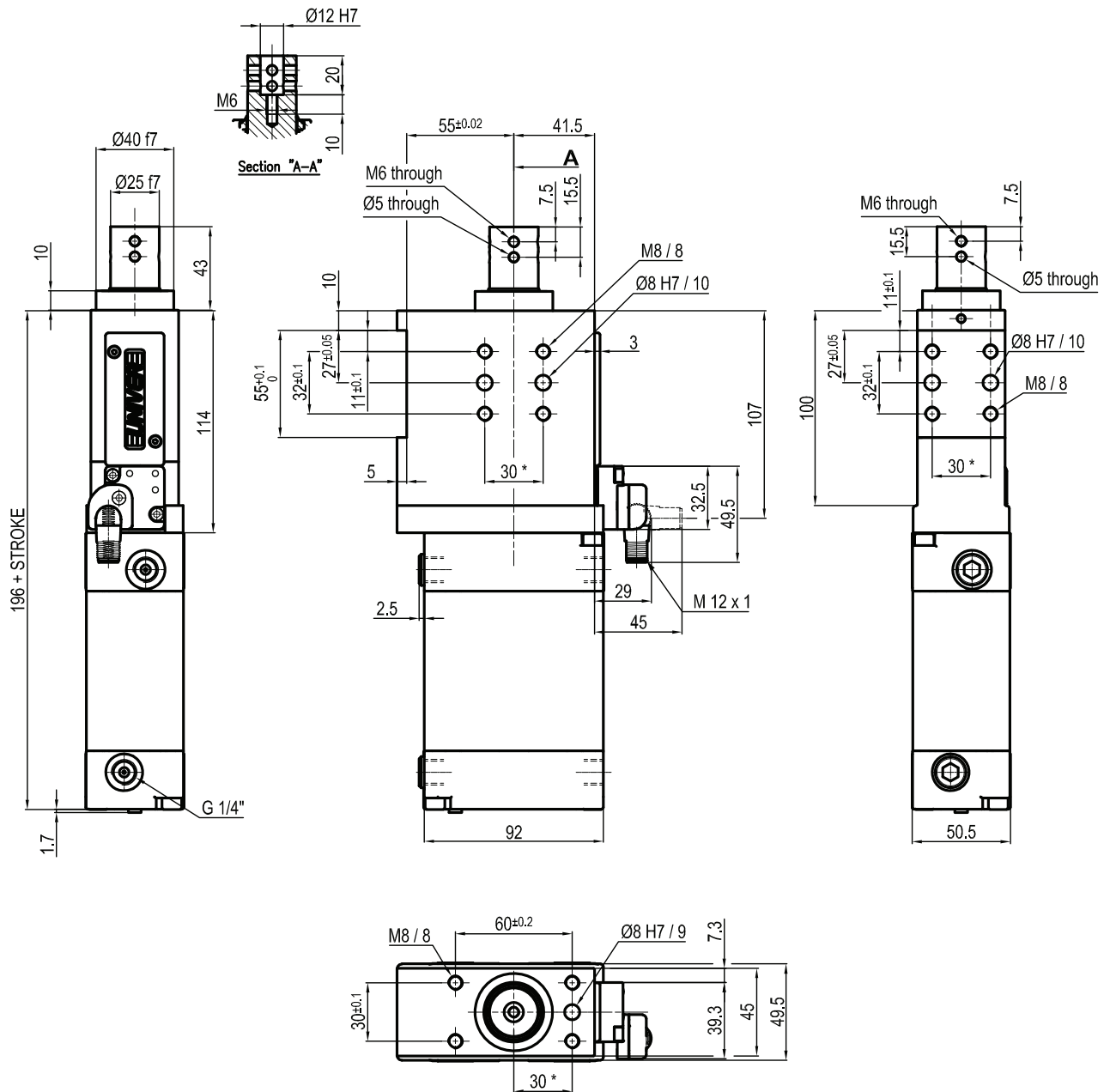

Bore \varnothing	Max. pull force 0,5 MPa	Max. push force 0,5 MPa	Max. torque 6 Nm	Max. deflection moment 7,5 Nm	Weight
63 mm	860 N	960 N	± 0,06°	± 0,03°	3,4 Kg

Min./Max. operating pressure: **0,4 / 0,6 MPa**
 Operating temperature: **5° ± 45° C**
 Strokes in mm.: **15 - 25 - 40 - 50 - 60**
 Electronic sensor with M12 swivel connector, from 0° to 90°
 Supply voltage: 10 ÷ 30 Vdc
 IP code: **IP 65**
 Pneumatic ports on both sides

* : TOLERANCE BETWEEN DOWELS ± 0,02, BETWEEN SCREW HOLES ± 0,1

Subject to technical modifications without notice

LCP63__KLR

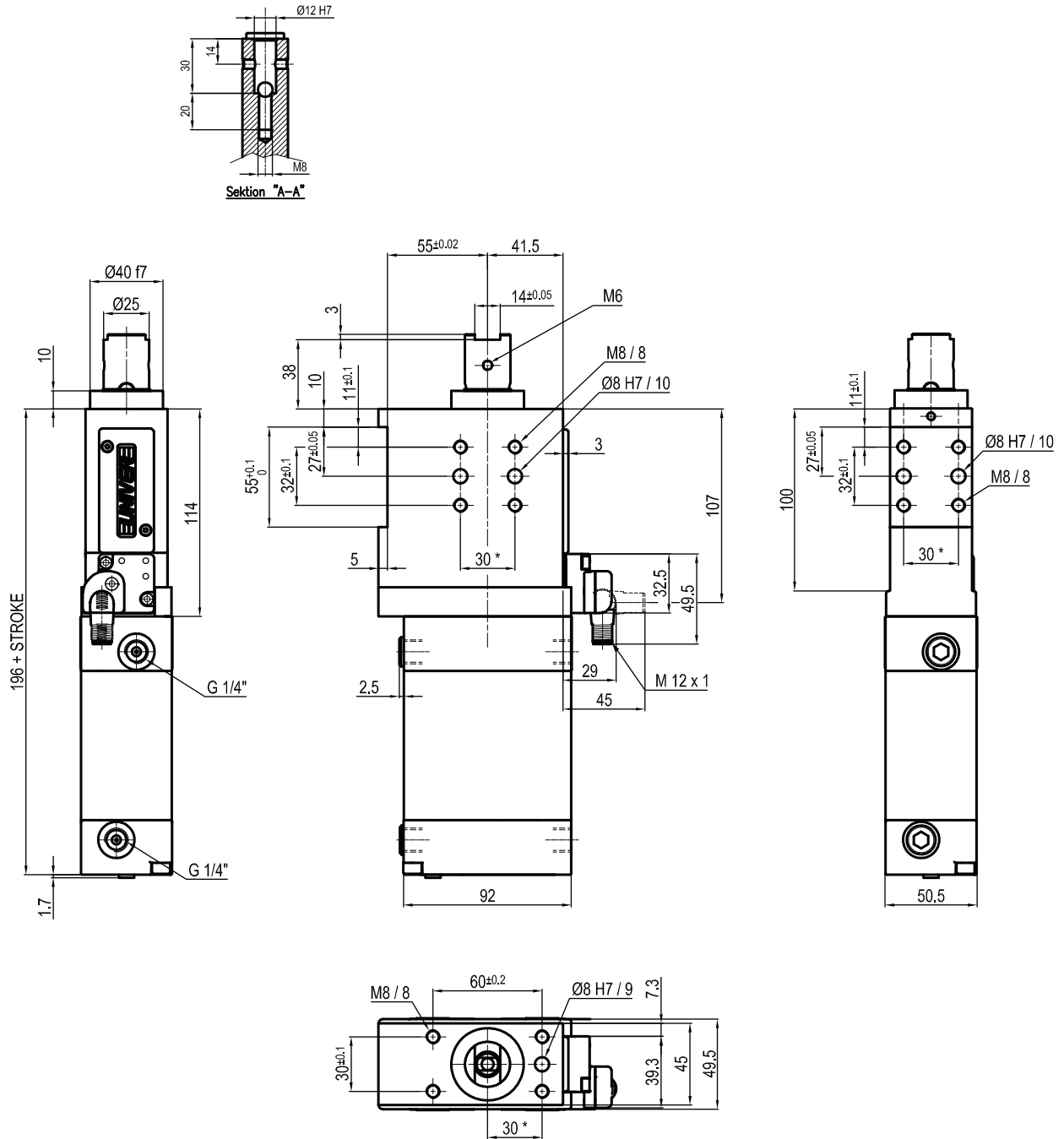

Bore Ø	Max. pull force 0,5 MPa	Max. push force 0,5 MPa	Max. torque 6 Nm	Max. deflection moment 7,5 Nm	Weight
63 mm	860 N	960 N	$\pm 0,06^\circ$	$\pm 0,03^\circ$	3,4 Kg

Min./Max. operating pressure: **0,4 / 0,6 MPa**
 Operating temperature: **5° ± 45° C**
 Strokes in mm.: **25 - 50**
 Electronic sensor with M12 swivel connector, from 0° to 90°
 Supply voltage: 10 ÷ 30 Vdc
 IP code: **IP 65**
 Pneumatic ports on both sides

* : TOLERANCE BETWEEN DOWELS $\pm 0,02$, BETWEEN SCREW HOLES $\pm 0,1$

Subject to technical modifications without notice

LCP63__KMR

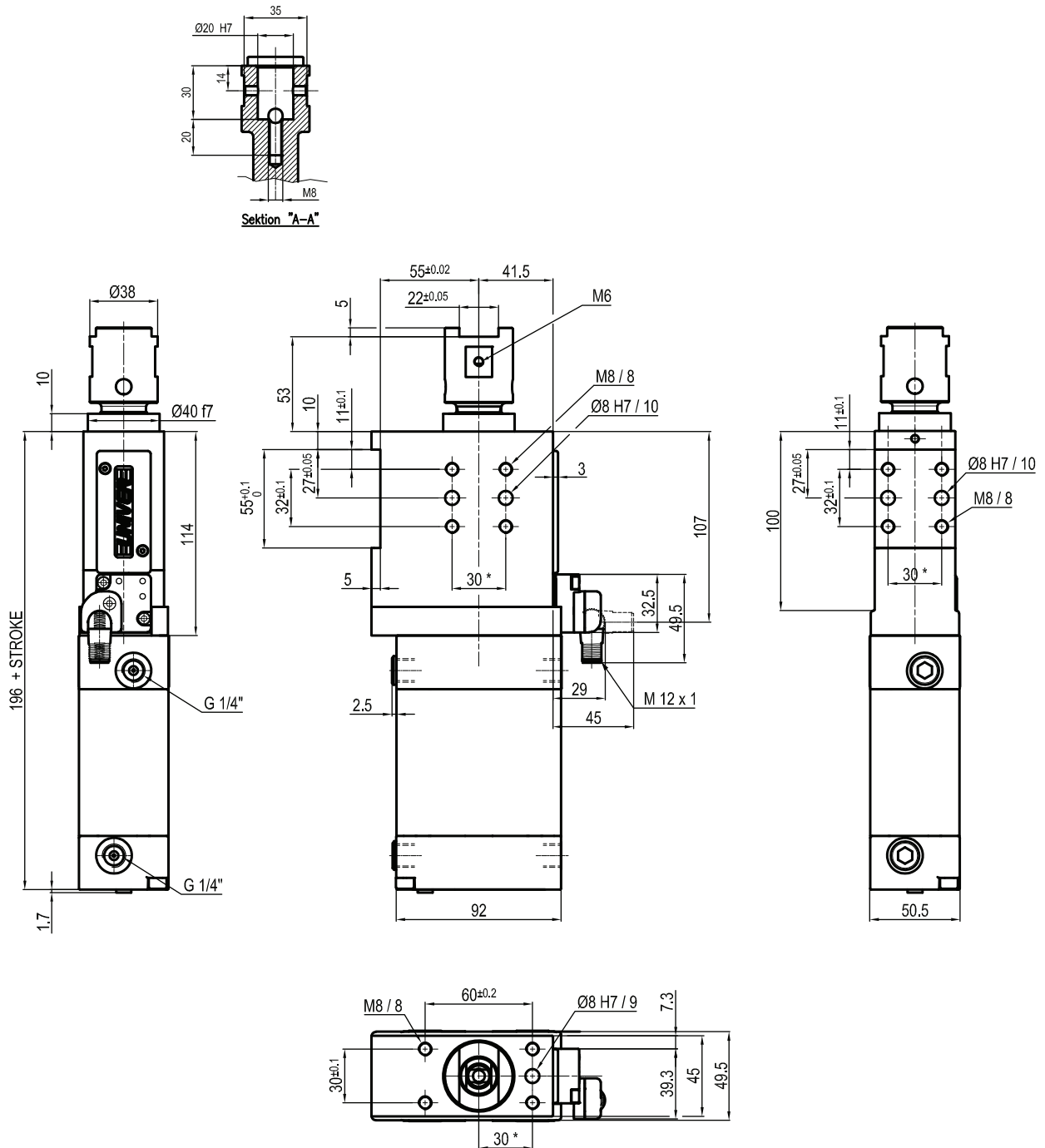

Bore Ø	Max. pull force 0,5 MPa	Max. push force 0,5 MPa	Max. torque 6 Nm	Max. deflection moment 7,5 Nm	Weight
63 mm	860 N	960 N	± 0,06°	± 0,03°	3,4 Kg

Min./Max. operating pressure: **0,4 / 0,6 MPa**
 Operating temperature: **5° ± 45° C**
 Strokes in mm.: **15 - 25 - 40 - 50 - 60**
 Electronic sensor with M12 swivel connector, from 0° to 90°
 Supply voltage: 10 ÷ 30 Vdc
 IP code: **IP 65**
 Pneumatic ports on both sides

* : TOLERANCE BETWEEN DOWELS ± 0,02, BETWEEN SCREW HOLES ± 0,1

Subject to technical modifications without notice