

Mod.
 TCxD
 TCMD
 TEXTD
DeviceNet
 FIELDBUS
 MODULE
 FOR
 PNEUMATIC
 MANIFOLD
 VALVES
 &
 I/O SIGNAL

- **Industry standard connection M8-M12-M23-7/8"**
- **Integrated connection to manifold valves - ISO VDMA & Compact Series**
- **24 coils valves capability**
- **Auxiliary max capability of 64digital input + 64digital output**
- **Optical & via network Diagnostic Monitor**
- **IP 65 protection grade**

Automation

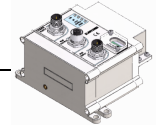

INDEX

Important note	3
Abbreviation	3
Legend of symbols	4
System description	4
Module Specifications	5
Module installation	6
P10 Compact manifold dimensions	6
15 Compact manifold dimensions	7
ISO VDMA manifold dimensions	7
EDS file specification	7
Connectors pin assignment	8
System supply connection	9
Network configuration	9
Terminal network resistor	10
How to Set the Module Address	10
AutoBode function mode (from 5.4 version and grater)	10
Module Diagnostic and Status indicators	11
Valves Coil & Input/Output Slot Allocation	12
Output manifold valves consumes-data definition	12
Auxiliary Digital OUTPUT consumes-data definition	12
Auxiliary Digital INPUT produces-data definition	13
Diagnostic definition and configuration	14
Auxiliary Digital I/O modules connection	16
Auxiliary Digital I/O modules specifications	17
Identification Label	17
Modules Assembly System	17
FieldBus Accessories ordering code	19
Conformity Declaration	19
System configuration examples	20
Dangers and residual risks	22
Dangers caused by Improper use	22
Correct and incorrect Use	22
Frequency of programmed maintenance	22
Instructions regarding removal / elimination of waste materials	22
Ordering string of fieldbus modules	23



Every conceivable measure has been taken to ensure the correctness and completeness of this documentation. However, as errors can never be fully excluded we would appreciate any information or ideas at any time.

/-----/

We wish to point out that the software and hardware terms as well as the trademarks of companies used and/or mentioned in the present manual are generally trademark or patent protected.

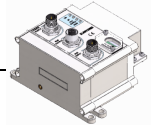

Important note

To ensure fast installation and start-up of the units described in this manual, we strongly recommend that the following information and explanations are carefully read and abided by.

Personnel Qualification

The use of the product detailed in this manual is exclusively geared to specialists having qualifications in PLC programming, electrical specialists or persons instructed by electrical specialists who are also familiar with the valid standards. UNIVER S.p.A. declines all liability resulting from improper action and damage to UNIVER S.p.A. products and third party products due to non-observance of the information contained in this manual.

Intended Use

For each individual application, the components supplied are to work with a dedicated hardware and software configuration. Modifications are only permitted within the framework of the possibilities documented in the manuals.

All other changes to the hardware and/or software and the non-conforming use of the components entail the exclusion of liability on part of UNIVER S.p.A.

Please direct any requirements pertaining to a modified and/or new hardware or software configuration directly to UNIVER S.p.A.

Safety Notes

Attention

Switch off the system prior to working on bus modules!

In the event of deformed contacts, the module in question is to be replaced, as its functionality can no longer be ensured on a long-term basis.

ESD (Electrostatic Discharge)

The modules are equipped with electronic components that may be destroyed by electrostatic discharge. When handling the modules, ensure that the environment (persons, workplace and packing) is well grounded. Avoid touching conductive components, e.g. gold contacts.

Abbreviation

DI Digital Input
DO Digital Output
I/O Input/Output
ID Identifier
HW Hardware
SW Software
LSB Least Significant Digit
MSD Most Significant Digit
V+ V- Logic & Sensor power supply
VA24 Auxiliary Output power supply

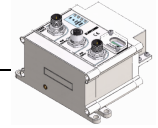

Legend of symbols

		Important Note
		Attention Danger
		More Information
		Recycling / Recyclable Material

System description

The TCxD is a modular fieldbus slave device for controlling manifold valve and digital input and output which use *DeviceNet* fieldbus.

The system structure here described consists of an MANIFOLD OUTPUT INTERFACE (1), of an FIELDBUS module (2) of an AUXILIARY DI/DO modules (3), the end module (4) completes the system.

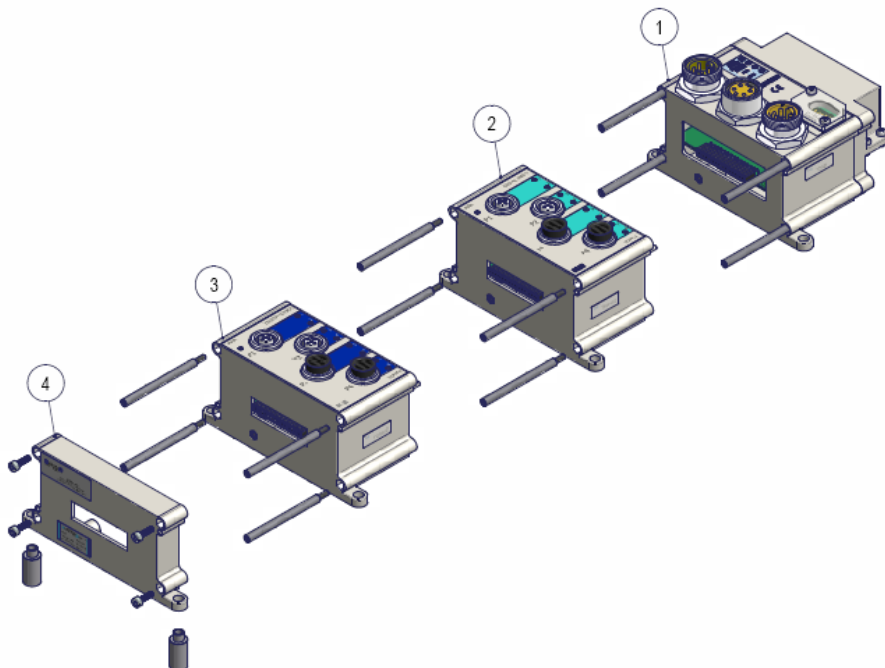

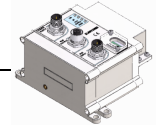

Module Specifications

FieldBus Data	
<i>Bus Input Connector</i>	<i>Circular 7/8 Male 5 pins or M23 17 pins Male</i>
<i>Bus Output Connector</i>	<i>Circular 7/8 Female 5 pins or M23 17 pins Female</i>
<i>Bus Function Displays</i>	<i>Module NETWORK Status_red-green</i>
<i>Auxiliary Function display</i>	<i>Logic Supply_green, Output Supply_green, Diag_red</i>
<i>Address Slave</i>	<i>Switchable 00 to...63</i>
<i>Communication Rate - AutoBode mode</i>	<i>125K,250,500Kbaude</i>
<i>FieldBus Connection Mode</i>	<i>Group 2 only-Polled-COS</i>
<i>EDS Filename</i>	<i>TCxDxxxxxxEDS</i>
Electrical Data	
<i>Auxiliary output Supply connector</i>	<i>Circular 7/8 Male 4 pins(1-VA24,4-OVA) or inside M23 17 pins Male</i>
<i>Logic - Digital Input Voltage Supply V+ / V-</i>	<i>24 Vdc +/- 20%</i>
<i>Logic Nominal Current</i>	<i>100mA</i>
<i>Digital Inputs max Current</i>	<i>1,5A @ 20°C - overload protected (20mA per input)</i>
<i>Output voltage Supply VA24</i>	<i>24 Vdc -10+15% (valves coil range)</i>
<i>Output Current VA24 (all output)</i>	<i>2,5A max - overload protected</i>
<i>Output Manifold Valves Capability</i>	<i>24 coil max - (12 bistable valves - 1,5A per 12 coils)</i>
<i>Auxiliary Digital Output Capability</i>	<i>max 40 digital output</i>
<i>Auxiliary Digital Input Capability</i>	<i>max 64 digital input</i>
Environmental Conditions	
<i>weight</i>	<i>370g</i>
<i>Dimentions</i>	<i>85 x 123 x 75 mm</i>
<i>MTBF - Mean Time Between Failures</i>	<i>197.359 Hours</i> <i>50°C</i>
<i>Protection Degree</i>	<i>IP 65</i> <i>IEC 60529</i>
<i>Relative humidity</i>	<i>5 to 85%</i> <i>IEC 60068-2-30</i>
<i>Operating Temperature</i>	<i>5°C ÷ 50°C</i> <i>IEC 60068-2-1</i>
<i>Storage Temperature</i>	<i>-25°C ÷ 80°C</i> <i>IEC 60068-2-2</i>
<i>Vibration</i>	<i>5g tested 10-500Hz</i> <i>IEC 60068-2-6</i>
<i>Shock operating</i>	<i>22g peak</i> <i>IEC 60068-2-27</i>

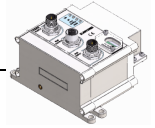

Module installation

Before installing the module, verify that all its parts are intact and have not been damaged during transport, pay attention to the overall dimensions.



We do recommend to fix the device in the specified hole with M4 screws on a single metal surface to grant a good ground connection

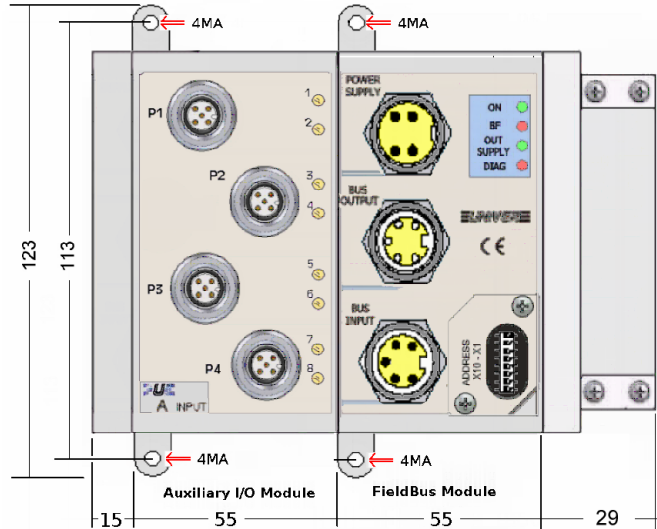
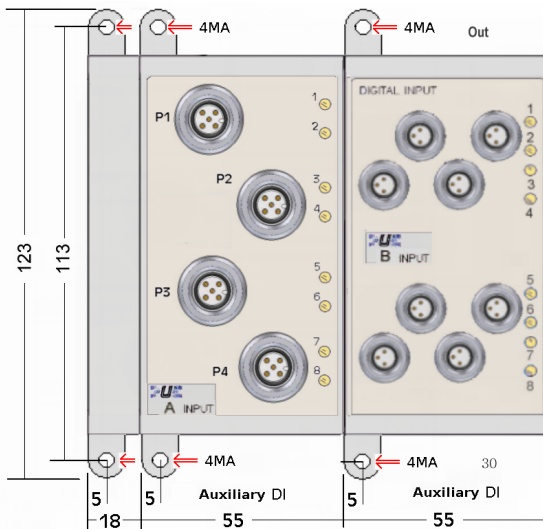

The overall length changes according to the numbers of the auxiliary I/O modules used and manifold valves type.

P10 Compact manifold dimensions

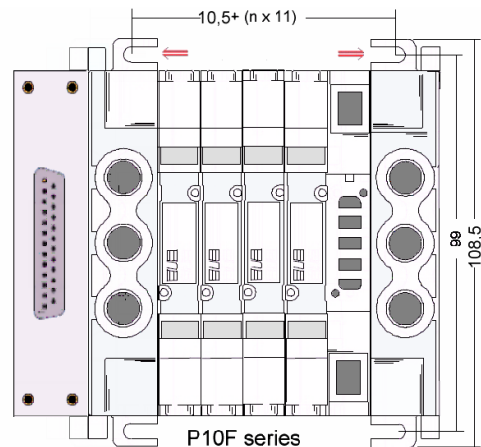
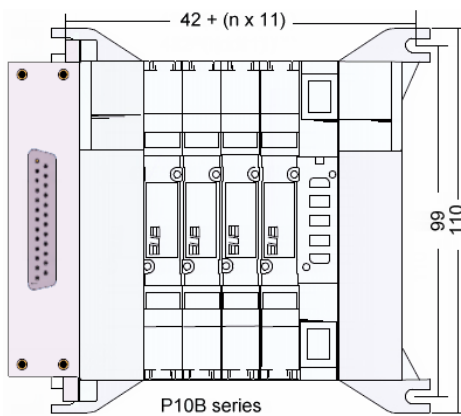

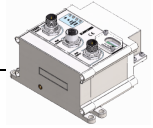

15 Compact manifold dimensions

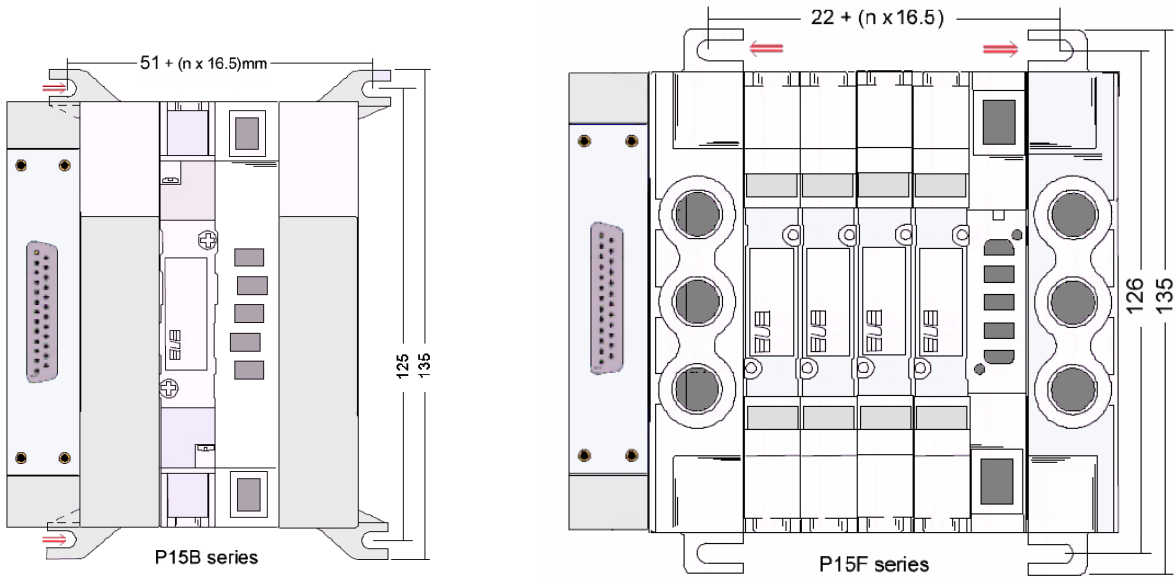

ISO VDMA manifold dimensions

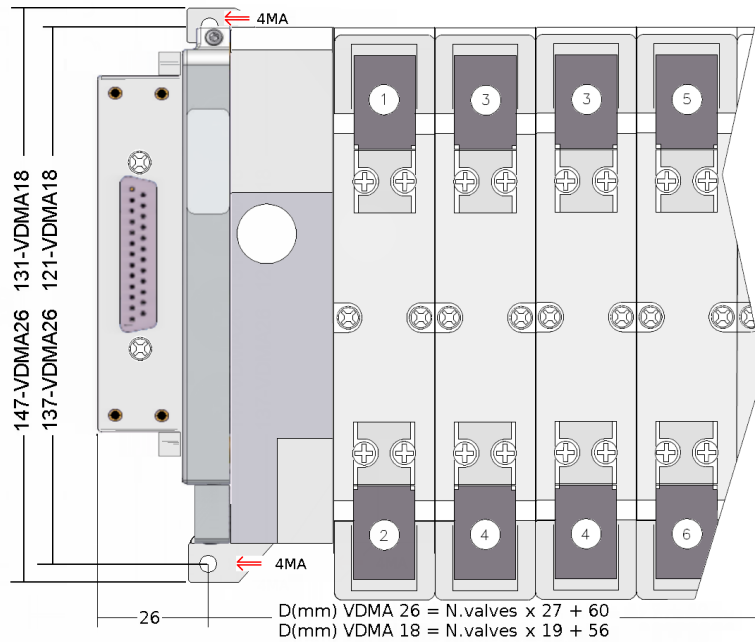

EDS file specification

EDS is an abbreviation of Electronic Data Sheet. EDS file on disk contains configuration data for specific device types, information about configurable attributes for a device, including object addresses of each parameter and provide for an open configuration tool while reading the device information and recognizing the device characteristics.

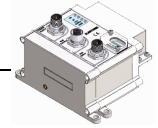

Connectors pin assignment

**Mod.
TCXD
TEXT**

Aux Supply (MALE)
7/8 " 4 pins
view front connector

DeviceNet
NET OUT (FEMALE)
7/8 " 5 pins
view front connector

NET IN (MALE)
7/8 " 5 pins
view front connector

Pin	Function
1	VA24 AUX OUT Supply
2	/
3	/
4	OVA AUX Com Supply

Pin	NET INP - OUT
1	Drain
2	V+
3	V-
4	CAN_High
5	CAN_Low

**Mod.
TCMD**

17pins M23

Bus OUT (FEMALE)
Looking into socket

Bus IN (MALE)
Looking into pins

Pin	Function
1	V -
2	OVA
3	VA24
4	V+
5	PE
13	CAN_High
14	CAN_Low
15	Reserved
16	Reserved
Case Connector PE	

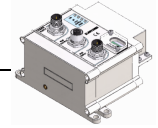

System supply connection



*Connect the module to the appropriate DeviceNet network cable
The PE connection has to be connected externally to the ground*

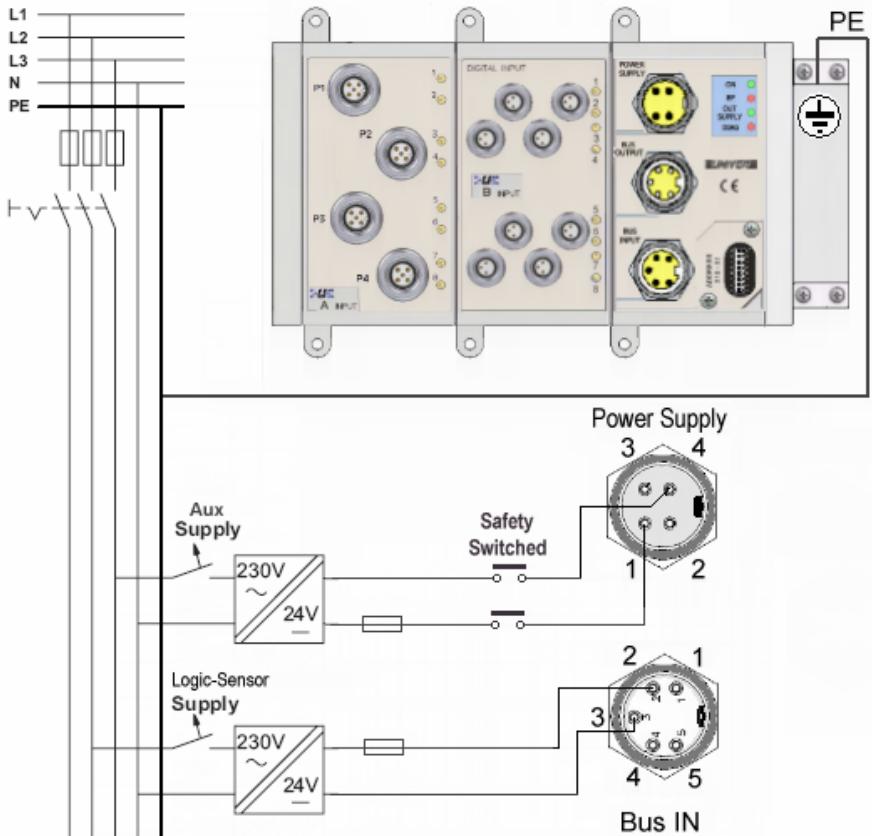

FieldBus Out
Terminal Network Resistor
Auxiliary Supply

FieldBus Inp

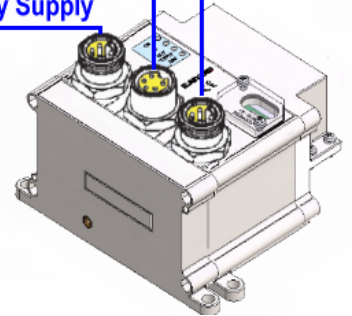

The fieldbus module requires a dual power supply:

V+/V- for the Logic & Sensor supply

VA24 (24Vdc -10%+15%) for output and manifold valves.

Supply Example



Network configuration

DeviceNet specifications defines for a maximum network distances the main trunk line and drop lines. Maximum distances depend on the baud rate used on the network:

Baud Rate	Trunk Line Length		Drop Length			
	Maximum Distance		Maximum		Cumulative	
	Meters	Feet	Meters	Feet	Meters	Feet
125k baud	500 m	1640 ft	6 m	20 ft	156 m	512 ft.
250k baud	250 m	820 ft	6 m	20 ft	78 m	256 ft.
500k baud	100 m	328 ft	6 m	20 ft	39 m	128 ft.

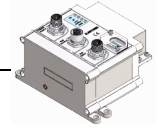

Terminal network resistor

A DeviceNet must be terminated at each end of the trunk line. The host controller and the last slave on the network must always be terminated to eliminate reflections, even if only two nodes are present.

The DeviceNet specifications for the terminating resistor are:

- 121 ohm
- 1% metal film
- ¼ Watt

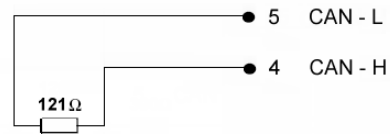

How to Set the Module Address

Max Valid Node Address are 01 to 63
 Each module is delivered set for node address 63
 The Dip or Rotary switches, are located on the top panel.

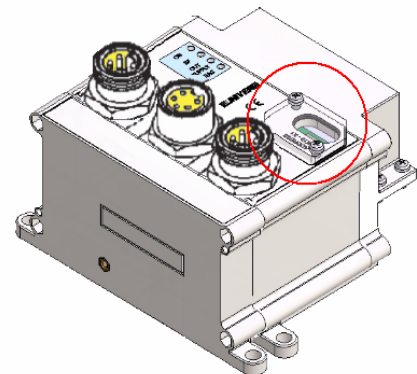
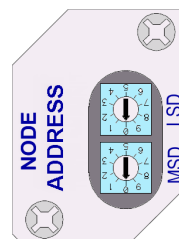

Rotary Switch	MSD	LSD
Node Address	X10 Most Significant Digit	X1 Least Significant Digit
Max add.	6	3



*To set the address, remove the cover, tourn rotary switch to the desired address, tourn OFF the device and then tourn ON again(The address is read only at power up)
 Remember to close the cover cap again to guarantee the protection degree*

AutoBode function mode (from 5.4 version and grater)



The device scans the network connection speed as you firstly supply it.

The autobaud detection function is operative if you connect the device in a previously configured and running network.

To change the operation speed it is necessary to set the master Offline, to edit the new baudrate, to turn off wait a few second and turn on the Slave.

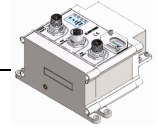

Module Diagnostic and Status indicators

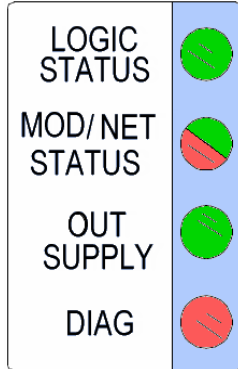

Des.	Colour	Meaning
LOGIC STATUS	Green LED	System ready
	ON:	Node power ON
	OFF:	Node off-line or not powered
MOD/NET STATUS	Green LED	Net Status
	ON:	On line connected
	OFF:	Not On line
	FLASH:	On line Not connected
	Red LED	Fault Status
	ON:	Unrecoverable fault
OUT SUPPLY	ON:	Recoverable fault
	Green LED	Actuator Supply
	ON:	Actuator Supply present
DIAG	OFF:	Actuator Supply missing
	Red LED	Diagnostic
	OFF:	No error
	FLASH: 1	Actuator supply missing
	FLASH: 2	Output overload
	FLASH: 3	High noise level
	FLASH: 4	Auxiliary Modules Fail
	FLASH: 5	No I/O module detected
	FLASH: 6	Reserved
	FLASH: 7	Reserved
	FLASH: 8	Reserved
	FLASH: 9	Auxiliary inputs module supply missing
FLASH: 10	Reserved	
FLASH: 11	More modules than those supported	

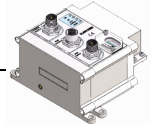

Valves Coil & Input/Output Slot Allocation

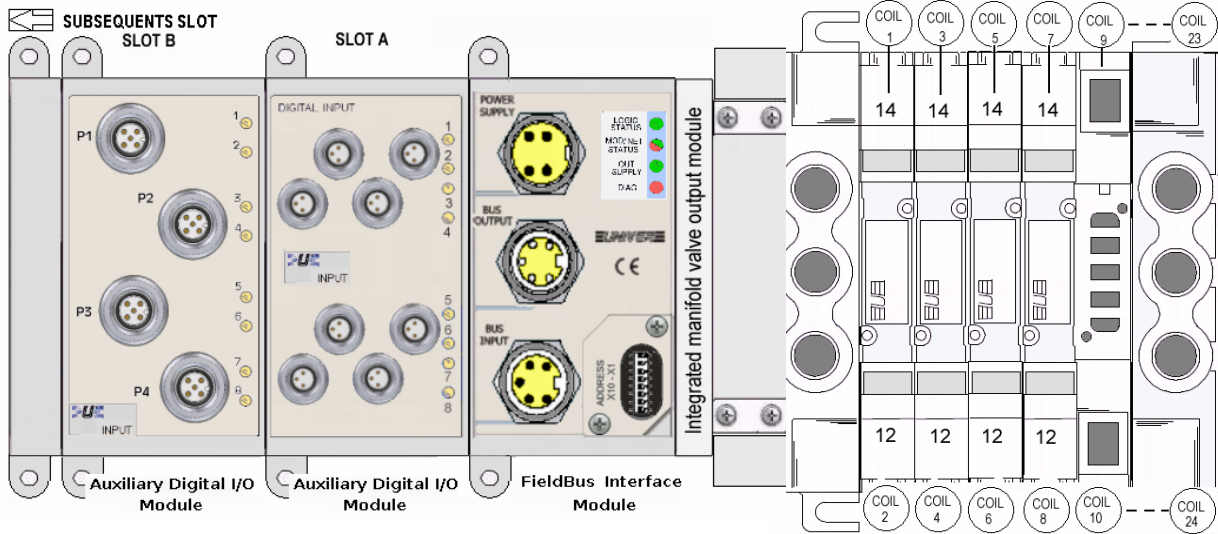

The physical position of the I/O expansion modules establishes the increment of the Data-Byte allocation according to a sequence which evolves increasingly from the FieldBus module to the left.

Output manifold valves consumes-data definition

		Coil	Byte-Bit Consumes	Coil	Byte-Bit Consumes	Coil	Byte-Bit Consumes
Valve Function	side14	1	0-0	9	1-0	17	2-0
	side12	2	0-1	10	1-1	18	2-1
	side14	3	0-2	11	1-2	19	2-2
	side12	4	0-3	12	1-3	20	2-3
	side14	5	0-4	13	1-4	21	2-4
	side12	6	0-5	14	1-5	22	2-5
	side14	7	0-6	15	1-6	23	2-6
	side12	8	0-7	16	1-7	24	2-7



The digital output manifold valves use always 24 Bit(3 Byte).

Auxiliary Digital OUTPUT consumes-data definition.

		Byte-Bit Consumes				
Module Slot		A	B	C	D	E
Port-Pin Function	P 1-4	3-0	4-0	5-0	6-0	7-0
	P 1-2	3-1	4-1	5-1	6-1	7-1
	P 2-4	3-2	4-2	5-2	6-2	7-2
	P 2-2	3-3	4-3	5-3	6-3	7-3
	P 3-4	3-4	4-4	5-4	6-4	7-4
	P 3-2	3-5	4-5	5-5	6-5	7-5
	P 4-4	3-6	4-6	5-6	6-6	7-6
	P 4-2	3-7	4-7	5-7	6-7	7-7

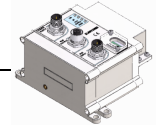

The maximum auxiliary digital output configurable are 40 Bit(5 Byte).



Auxiliary Digital INPUT produces-data definition

Module Slot		Byte-Bit Produces							
		A	B	C	D	E	G	H	
Port-Pin Function	P 1-4	0-0	1-0	2-0	3-0	4-0	5-0	6-0	
	P 1-2	0-1	1-1	2-1	3-1	4-1	5-1	6-1	
	P 2-4	0-2	1-2	2-2	3-2	4-2	5-2	6-2	
	P 2-2	0-3	1-3	2-3	3-3	4-3	5-3	6-3	
	P 3-4	0-4	1-4	2-4	3-4	4-4	5-4	6-4	
	P 3-2	0-5	1-5	2-5	3-5	4-5	5-5	6-5	
	P 4-4	0-6	1-6	2-6	3-6	4-6	5-6	6-6	
	P 4-2	0-7	1-7	2-7	3-7	4-7	5-7	6-7	



The maximum auxiliary digital input configurable are 64 Bit(8 Byte).

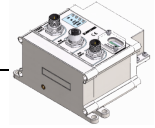

Diagnostic definition and configuration

Is possible to setting diagnostic function in two different mode: **MAIN** and **EXTENDED**.

The default setting of device diagnostic mode is **“MAIN”**.

For change the diagnostic mode in **“EXTENDED”**, set address to **99**, turn off the device, wait a few second and turn on the device, set the real address network and turn off the device, wait a few second and turn on the device.

To return in the **“MAIN”** mode repeat the operation using the address **88**.

Important: The diagnostic Data Bytes is available as Produces Data Byte **subsequent** to the Auxiliary Digital Inputs Produces Data Byte.

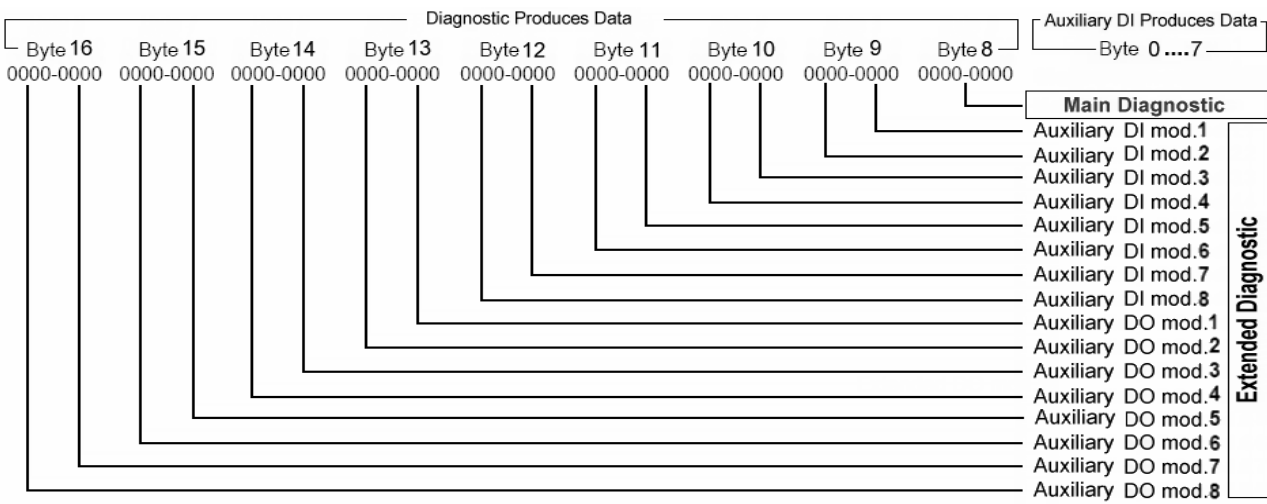

The **MAIN** diagnostic mode produce one(1) Byte which summarizes all the system errors.

MAIN DIAGNOSTIC BITS FUNCTION		
Bit	Name	Description
0	VA24 Aux power loss	This Bit becomes active when the VA24 is no power supply (Power Supply connector). In this condition the coils of the valves are not supplied to even if the logic command is ON.
1	Module fail	This Bit becomes active when the module is in fault condition (replace the module)
2	Output fail	This Bit becomes active, when one or more outputs are overloaded or in short circuit condition for the auxiliary output module or for the manifold outputs, for device manufactured from January 2011 (see note (1)). Not supported on TB3D and TB4D module.
3	High noise level	This Bit becomes active, when internal bus communication errors are detected, caused by a high level of noise coupling the cables connected to the module
4	Input power supply loss	This Bit becomes active when an overload or short circuit is present in one or more input module connectors
5-6	Reserved	
7	Module info Monitor	This Bit becomes active, when module extended diagnostic are present

- (1) If the error is generated from the onboard manifold it is possible to reset the error by switching OFF all the 24 manifold outputs, wait 1 second, and then apply the right outputs states again. In case of short circuit or over load all the 24 manifold outputs are switched OFF.

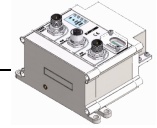

The **EXTENDED diagnostic** mode produce eight (8) Byte in which they come defined the diagnostic functions of the single auxiliary modules.

EXTENDED DIAGNOSTIC NIBBLE FUNCTION	
Bin.Code	Description
0000	This Value indicate no error present
0001	This Value indicate VA24 voltage missing, only auxiliary output module (2)
0010	This Value indicate one or more outputs in overloaded or in short circuit condition (2)
0011	This Value indicate detection of internal bus communication errors, caused by an high level of noise coupling the cables connected to the module
0100	This Value indicate module fail
0101	This Value indicate overload or short circuit is present in one or more input module connectors

Code value from **0110** to **1111** are not assigned

(2) Output module only.

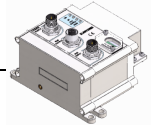

Auxiliary Digital I/O modules connection

COD. TC8I412
 N.8 Digital Input - M12
COD. TC16I812
 N.16 Digital Input - M12
COD. TC8U412
 N.8 Digital Output - M12

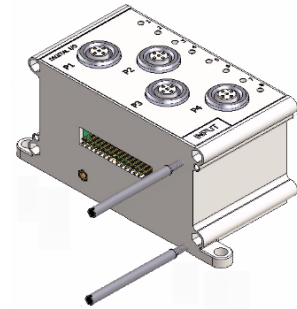

Input M12 (Female)
 Output M12 (Female)
 Looking into sockets

Pin	TC8I412	TC8U412
1	VLS24	-
2	Input 2	Output 2
3	0VLS	0VA
4	Input 1	Output 1
Case	Cable Shield	Cable Shield

COD. TC8I808
 N.8 Digital Input - M8



Input M8 (Female)
 Looking into sockets

Pin	TC8I808
1	VLS24
3	0VLS
4	Input

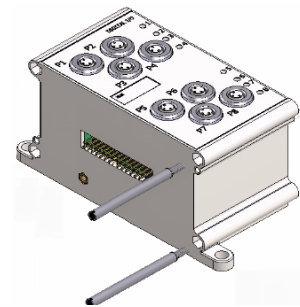

P1-P2 Pin No.	Part Number TCR32ID	Part Number TCR32UD
1	Input 0-0	Output 0-0
2	Input 0-1	Output 0-1
3	Input 0-2	Output 0-2
4	Input 0-3	Output 0-3
5	Input 0-4	Output 0-4
6	Input 0-5	Output 0-5
7	Input 0-6	Output 0-6
8	Input 0-7	Output 0-7
9	Input 1-0	Output 1-0
10	Input 1-1	Output 1-1
11	Input 1-2	Output 1-2
12	Input 1-3	Output 1-3
13	Input 1-4	Output 1-4
14	Input 1-5	Output 1-5
15	Input 1-6	Output 1-6
16	Input 1-7	Output 1-7
17/18	-	-
19/20	0V Input	-
21/22	+24V Input	-
23/24	-	0VA
25	-	-
Case	Cable Shield	Cable Shield

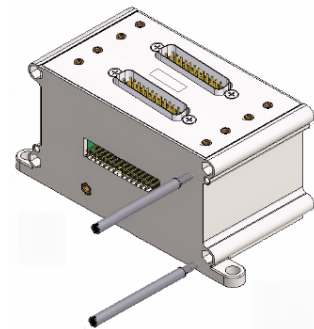

COD. TCR32UD
 16+16 Digital Output
 Remote module

COD. TCR32ID
 16+16 Digital Input
 Remote module

COD. TCR1616
 16Digital Input
 16Digital Output
 Remote module

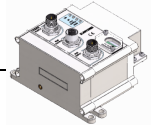

Auxiliary Digital I/O modules specifications

Input Module Specification

Part Code	TC8I412		TC8I808	TCR32ID
Termination type	Circular 4 x M12		Circular 8 x M8	Sub D 2 x 25pins
Input per Module	8		8	16+16
Switching Logic	2 or 3 wire PNP devices			
Operating Voltage Supply VS24	24V dc +/- 15%			
Sensor Source Current per input max	20mA			
Signal logic "OFF"	0V dc to 5V dc			
Signal logic "ON"	10Vdc to 30V dc			
Typical input Current ON state max	5mA			
Status Display	Valid Input - green indicator ON			

Output Module Specification

Part Code	TC8U412	TCR32UD
Termination type	Circular 4 x M12 size	Sub D 2 x 25pins
Output per module	8	16+16
Switching Logic	Sourcing Output	
Output Voltage Supply VA24	24 V dc -10% + 15% (valves coil range)	
ON state Current per Output	0.3A	
ON state Surge Current per Output 10mS	1.0A	
Overload protected per Output	1.2°	
Module Current rating max	1.5A (1)	
Status Display	Energized Output - yellow indicator ON	

Environmental Conditions

Weight	170g-300g	
Overall Dimentions	55 x 123 x 75 mm	
MTBF - Mean Time Between Failures	(under testing)	50°C
Protection Degree	IP 65	IEC 60529
Relative humidity	5 to 85%	IEC 60068-2-30
Operating Temperature	5°C ÷ 50°C	IEC 60068-2-1
Storage Temperature	-25°C ÷ 80°C	IEC 60068-2-2
Vibration	5g tested 10-500Hz	IEC 60068-2-6
Shock operating	22g peak	IEC 60068-2-27



Make sure all connectors and caps are securely tightened to properly seal the connections against leaks and maintain IP65 requirements. I/O cable length should be less than 10 meters

(1) The max current available for all output modules included into the system is 2.5Amax.

Identification Label

Model Voltage Supply Range Nominal Current Supply -VL24		Protection Degree Production Year Serial No.
---	--	--

Modules Assembly System

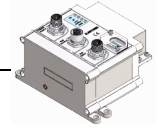



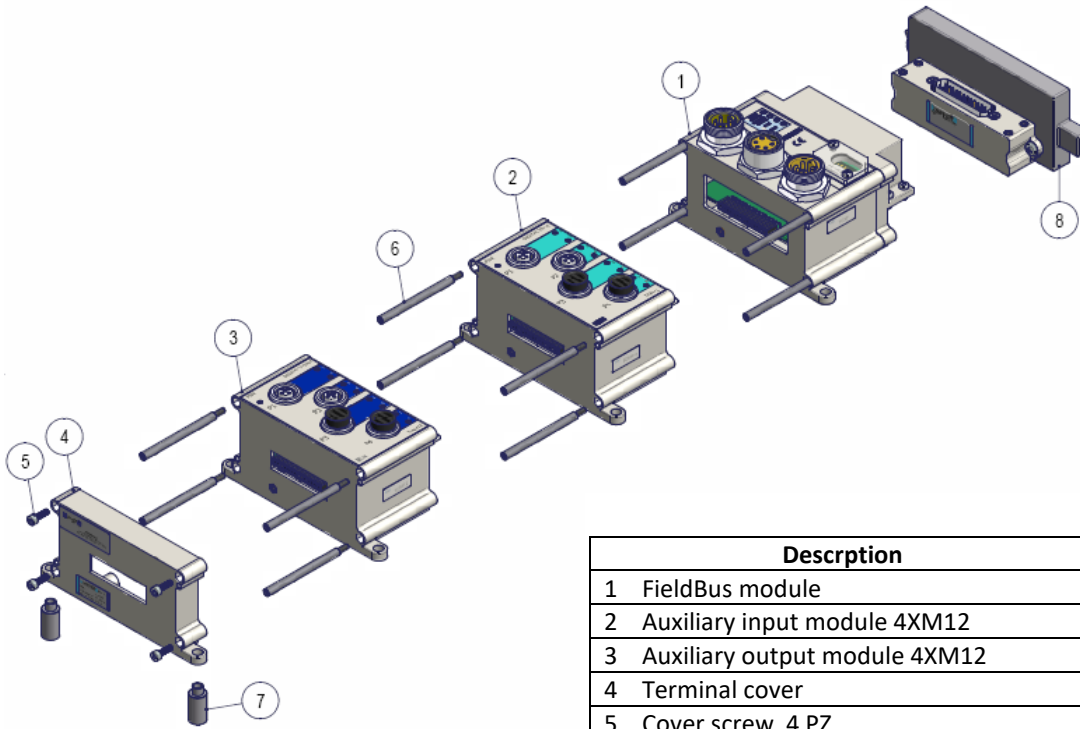

The auxiliary inputs and outputs modules will be connected to FieldBus module on the opposite side of the manifold valves.

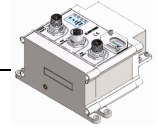

Descrption	Part code
1 FieldBus module	TCxD
2 Auxiliary input module 4XM12	TC8I412
3 Auxiliary output module 4XM12	TC8U412
4 Terminal cover	included
5 Cover screw 4 PZ	included
6 Terod auxiliary I/O 12 PZ	included
7 Assembly support I/O 4PZ	included
8 Manifold multi way sub D25 pins adpt	included



FieldBus Accessories ordering code

	Code	Description	Size	Protection Degree
	TZ-M578T	DeviceNet (5-pins, male) Network termination (120ohm)	7/8	IP65
	TZ-F578	DeviceNet (5-pins, female)	7/8	IP65
	TZ-M578	DeviceNet (5-pins, male)	7/8	IP65
	TZ-M578T	DeviceNet (5-pins, male) Network termination (120ohm)	7/8	IP65



Additional accessories for connecting can be found on www.univer-group.com website

Conformity Declaration

Univer S.p.A. declares under the own responsibility that the Device in object is in compliance with the EMC directive 2004/108/EC, with amendaments for 92/31/EEC and 93/68/EEC through conformance with the following Harmonised European standards:

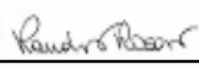
Date:	22 of February, 2007	Harmonised European standards:
Device:	Multi I/O Manifold Valves Control	EN 61000-4-3 (1996) EN 61000-4-6 (1996)
Term:	TCxD	EN 61000-4-2 (1996) EN 61000-4-4 (1996)
Manufacturer:	Univer S.p.A. Via Eraclito, 31 20128 Milano ITALY tel. +39 02252981 fax. +39 0225298310	EN 61000-4-5 (1995) EN 61000-4-6 (1996) EN 61000-4-8 EN 61000-4-11 EN 61000-6-2 (1995) EN 61000-6-4 (1993)
		
R&D Manager signature:	_____	

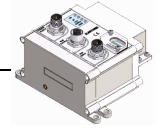

System configuration examples

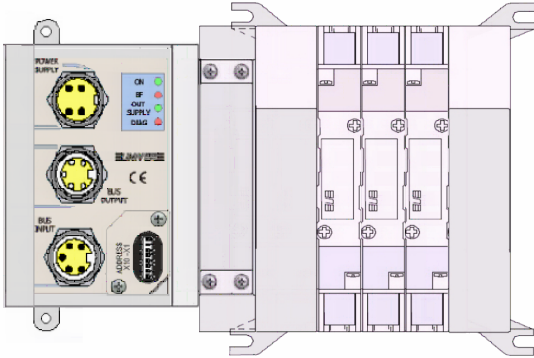

TCxx fieldbus device with integrated COMPACT MANIFOLD

TCxx fieldbus device with integrated COMPACT MANIFOLD and remote expansion module for distributed manifolds connection

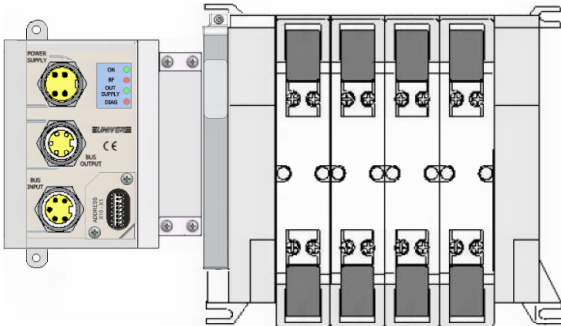
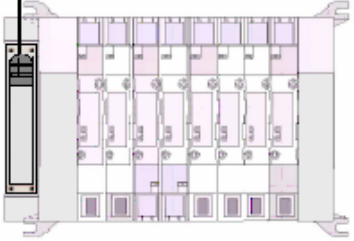
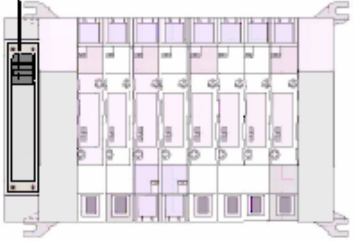
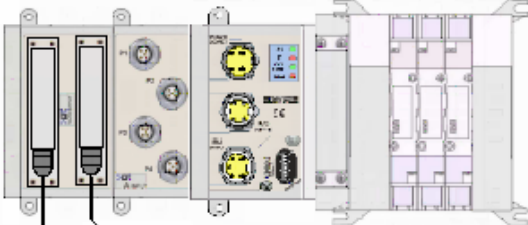

TCxx fieldbus device with integrated ISO VDMA MANIFOLD

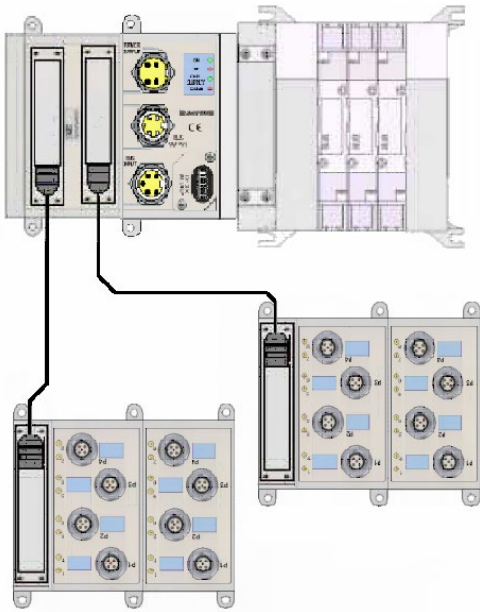
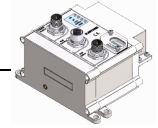

TCxx fieldbus device with integrated COMPACT MANIFOLD and remote expansion module for distributed manifolds connection

TCxx fieldbus device with integrated COMPACT MANIFOLD and remote expansion module for passive MULTIBOX modules

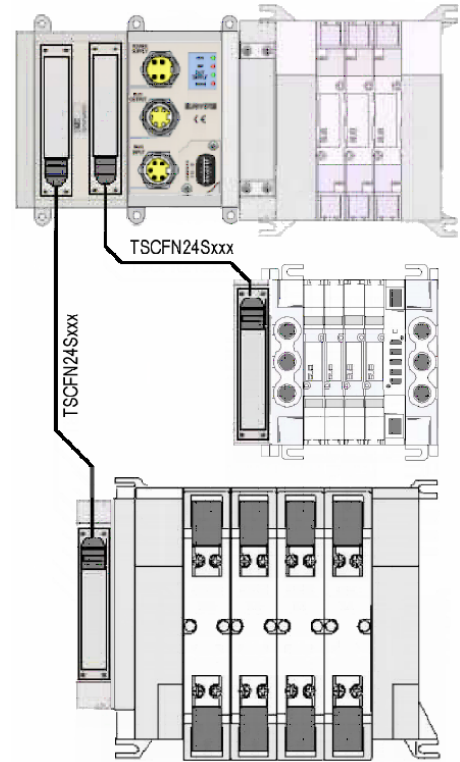

TExx fieldbus device with remote expansion module for passive MULTIBOX modules

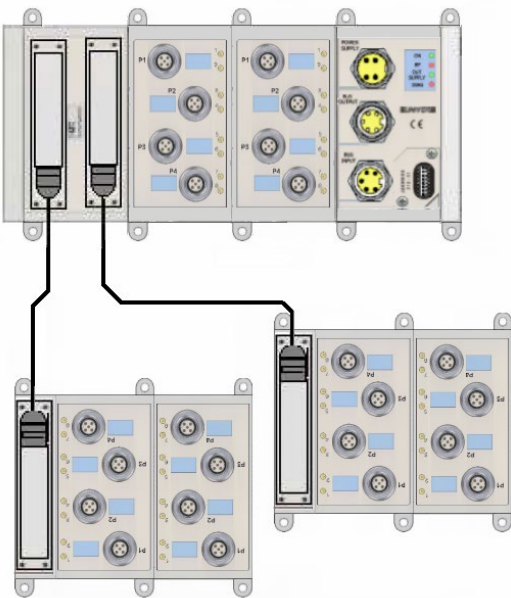

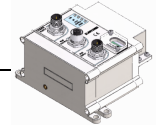

Dangers and residual risks

There aren't residual risks that may cause damage to the health of the person exposed. In case of maintenance, the operator is alerted by a visual sign placed near the high-risky areas, where there could be voltage dangers.



Dangers caused by Improper use



It is recommended to use only original spare parts. They are to be considered including the "misuse conditions " of any modifications or changes of any kind, that the user arbitrarily.



Correct and incorrect Use



The FieldBus Slave control unit, in all its models can be used only as reported on the operative manual manufacturer. The requirements of security and reliability of the unit are guaranteed only by using original components.



Frequency of programmed maintenance

The unit was designed and built so as not to require a specific scheduled maintenance.



Instructions regarding removal / elimination of waste materials

If you want to disassemble the unit is necessary to observe some basic rules to safeguard the health and the environment.



*Cables, liners and plastic components, must be disposed separately from all other materials
The metal parts must be grouped by type of material.*



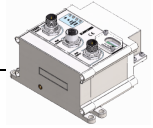

Ordering string of fieldbus modules

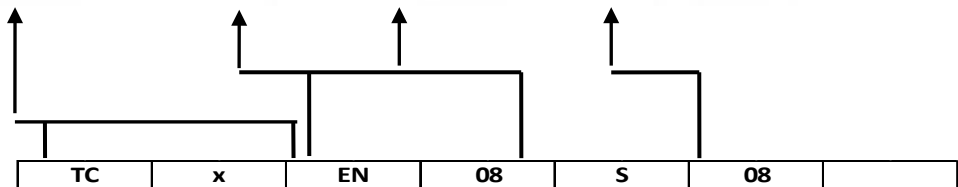

SERIES	
TC	Manifold plugin & I/O module
TE	I/O module

SIZE	
x	Standard M12 connection
M	Multibus M23 connection (1)

FIELDBUS		
C	Canopen	64+64 I/O
D	Devicenet	64+64 I/O
P	Profibus DP	64+64 I/O
PN	Profinet	64+88 I/O
EN	Ethernet/IP	64+88 I/O
EC	EthernetCAT	64+88 I/O

AUXILIARY DIGITAL INPUT	
	If no other module present (Leave Blank)
N° 00-08-16-24-32-40-48-56-64	

DIGITAL INPUT CONNECTOR SIZE	
	If no other module present (Leave Blank)
S	M12 Standard digital input (4x2)
H	M12 High-Density digital input (TC16I812 8x2)
8	M08 digital input (8x1)
0	If only remote module present

AUXILIARY DIGITAL OUTPUT	
	If no other module present (Leave Blank)
N° 00-08-16-24-32-40-48-56-64	

DIGITAL I/O REMOTE MODULE	
	If no remote module present (Leave Blank)
32IN	One TCR32ID module 16+16 digital input
64IN	Two TCR32ID module 16+16 digital input
32UD	One TCR32UD module 16+16 digital output
64UD	Two TCR32UD module 16+16 digital output
1616	One TCR1616 module 16 digital input + 16 digital output
3232	One TCR32ID module 16+16 digital input + One TCR32UD module 16+16 digital output
6464	Two TCR32ID module 16+16 digital input + Two TCR32UD module 16+16 digital output

(1) Only for Devicenet and Profibus