

* : TOLERANCE BETWEEN DOWELS ± 0,02, BETWEEN SCREW HOLES ± 0,1
 ** : AREA TO ACCESS ANGLE ADJUSTMENT
 *** : DIMENSIONS TO BE RESPECTED IN CASE OTHER MANUAL LEVERS ARE USED

Bore Ø	Holding moment	Clamping moment (0,5 MPa)	Weight (clamping arm not included)
40 mm	600 Nm	170 Nm	2,1 Kg

Min./Max. operating pressure: **0,4 / 0,6 MPa**
 Operating temperature: **5° ÷ 45° C**
 Opening angle: **adjustable**
 Without arm
 With hand lever
 Electronic sensor with M12 swivel connector, from 0° to 90°
 Supply voltage: 10 ÷ 30 Vdc
 IP code: **IP 65**
 Pneumatic ports on both sides

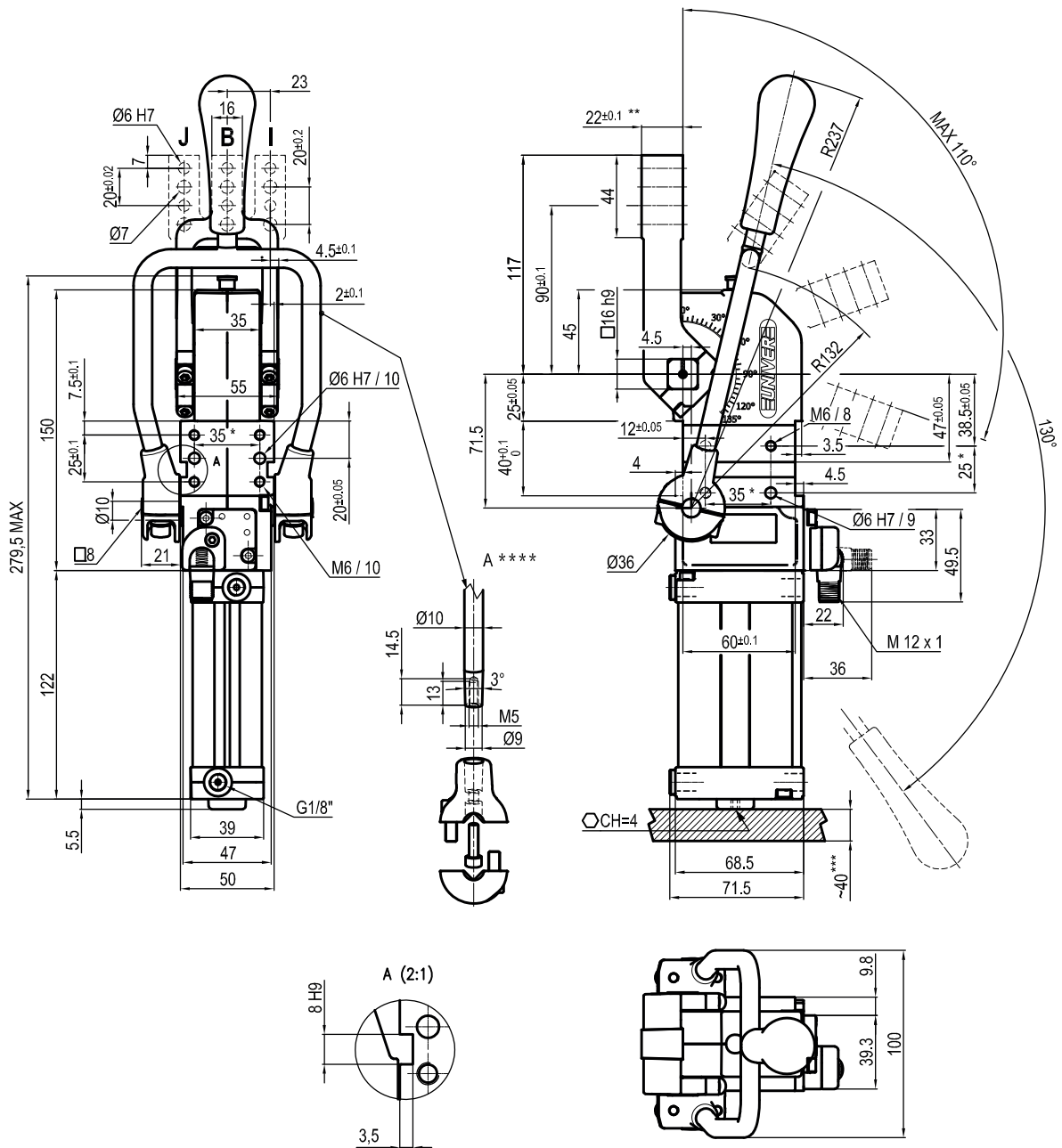

* : TOLERANCE BETWEEN DOWELS $\pm 0,02$, BETWEEN SCREW HOLES $\pm 0,1$
 ** : TOLERANCE AT 80 mm FROM PIVOT POINT
 *** : AREA TO ACCESS ANGLE ADJUSTMENT
 **** : DIMENSIONS TO BE RESPECTED IN CASE OTHER MANUAL LEVERS ARE USED

UCBT400 __ K0
6 ARM STYLE

7 ARM TYPE

6 7

 B = Central
 I = Right
 J = Left

 A = Aluminium
 S = Steel

Bore \varnothing	Holding moment	Clamping moment (0,5 MPa)	Weight (clamping arm not included)
40 mm	600 Nm	170 Nm	2,1 Kg

Min./Max. operating pressure: **0,4 / 0,6 MPa**
 Operating temperature: **5° ÷ 45° C**
 Opening angle: **adjustable from 0° to 110°**
 Arm position: **180°**
 With hand lever
 Electronic sensor with M12 swivel connector, from 0° to 90°
 Supply voltage: **10 ÷ 30 Vdc**
 IP code: **IP 65**
 Pneumatic ports on both sides

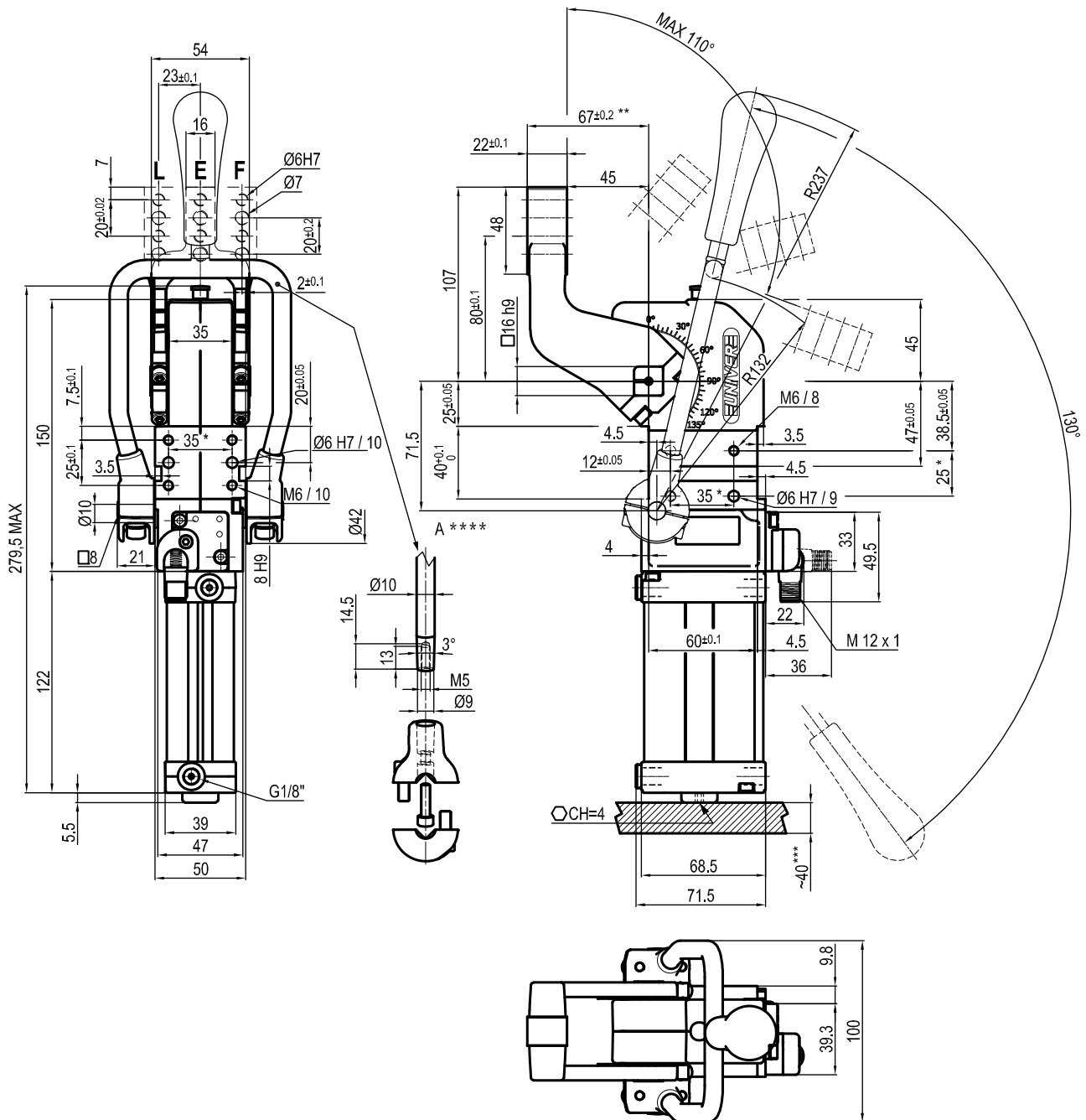

* : TOLERANCE BETWEEN DOWELS $\pm 0,02$, BETWEEN SCREW HOLES $\pm 0,1$
 ** : TOLERANCE AT 80 mm FROM PIVOT POINT
 *** : AREA TO ACCESS ANGLE ADJUSTMENT
 **** : DIMENSIONS TO BE RESPECTED IN CASE OTHER MANUAL LEVERS ARE USED

UCBT400 __ K0
6 7
6 ARM STYLE

 E = Central
 F = Right
 L = Left

7 ARM TYPE

 A = Aluminium
 S = Steel

Bore \varnothing	Holding moment	Clamping moment (0,5 MPa)	Weight (clamping arm not included)
40 mm	600 Nm	170 Nm	2,1 Kg

Min./Max. operating pressure: **0,4 / 0,6 MPa**
 Operating temperature: **5° ÷ 45° C**
 Opening angle: **adjustable from 0° to 110°**
 Arm position: **180°**
 With hand lever
 Electronic sensor with M12 swivel connector, from 0° to 90°
 Supply voltage: **10 ÷ 30 Vdc**
 IP code: **IP 65**
 Pneumatic ports on both sides

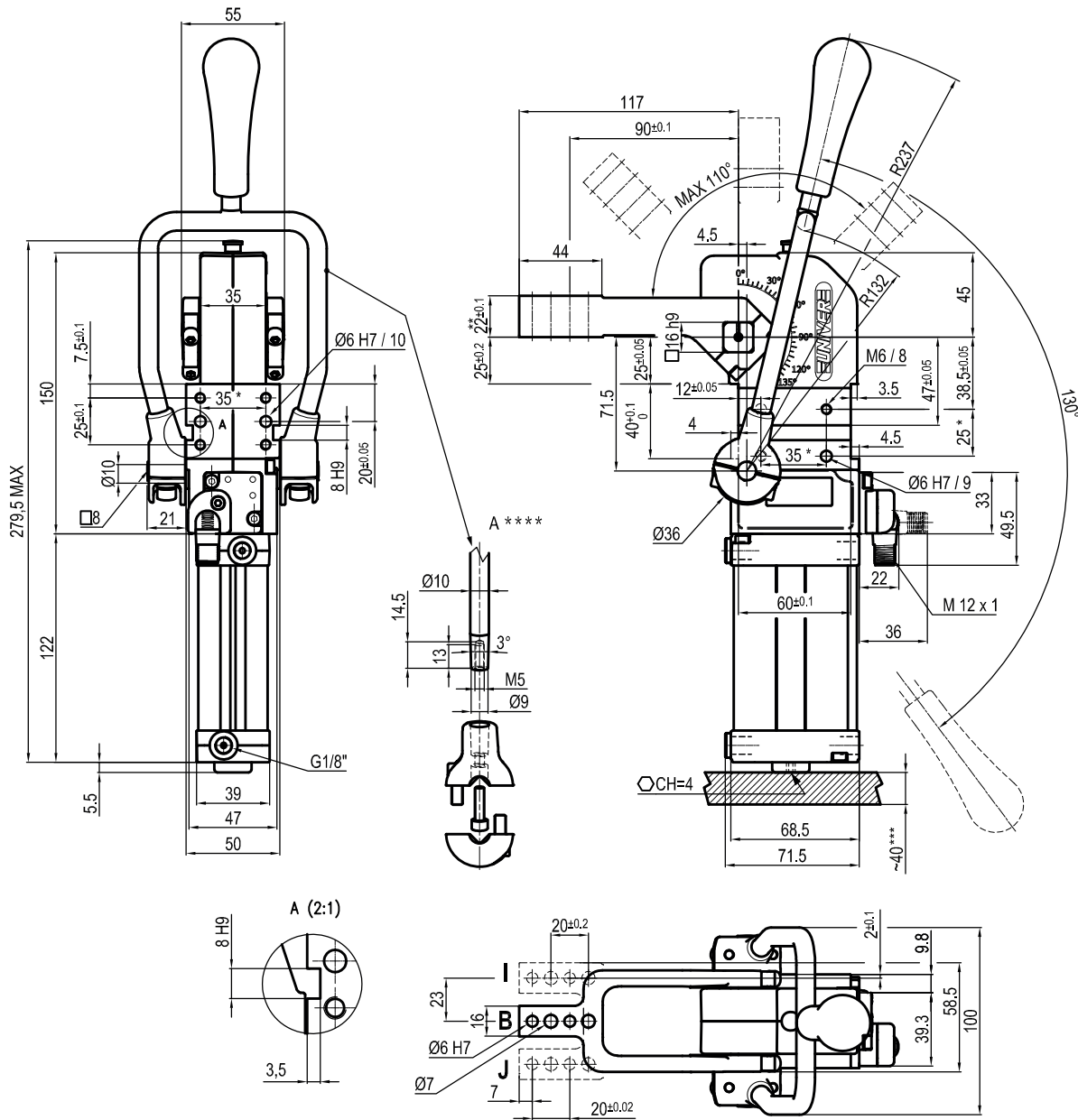

* : TOLERANCE BETWEEN DOWELS $\pm 0,02$, BETWEEN SCREW HOLES $\pm 0,1$
 ** : TOLERANCE AT 80 mm FROM PIVOT POINT
 *** : AREA TO ACCESS ANGLE ADJUSTMENT
 **** : DIMENSIONS TO BE RESPECTED IN CASE OTHER MANUAL LEVERS ARE USED

UCBT40V __ K0
6 ARM STYLE

7 ARM TYPE

6 7

 B = Central
 I = Right
 J = Left

 A = Aluminium
 S = Steel

Bore \varnothing	Holding moment	Clamping moment (0,5 MPa)	Weight (clamping arm not included)
40 mm	600 Nm	170 Nm	2,1 Kg

Min./Max. operating pressure: **0,4 / 0,6 MPa**
 Operating temperature: **5° ÷ 45° C**
 Opening angle: **adjustable from 0° to 110°**
 Arm position: **90°**
 With hand lever
 Electronic sensor with M12 swivel connector, from 0° to 90°
 Supply voltage: **10 ÷ 30 Vdc**
 IP code: **IP 65**
 Pneumatic ports on both sides

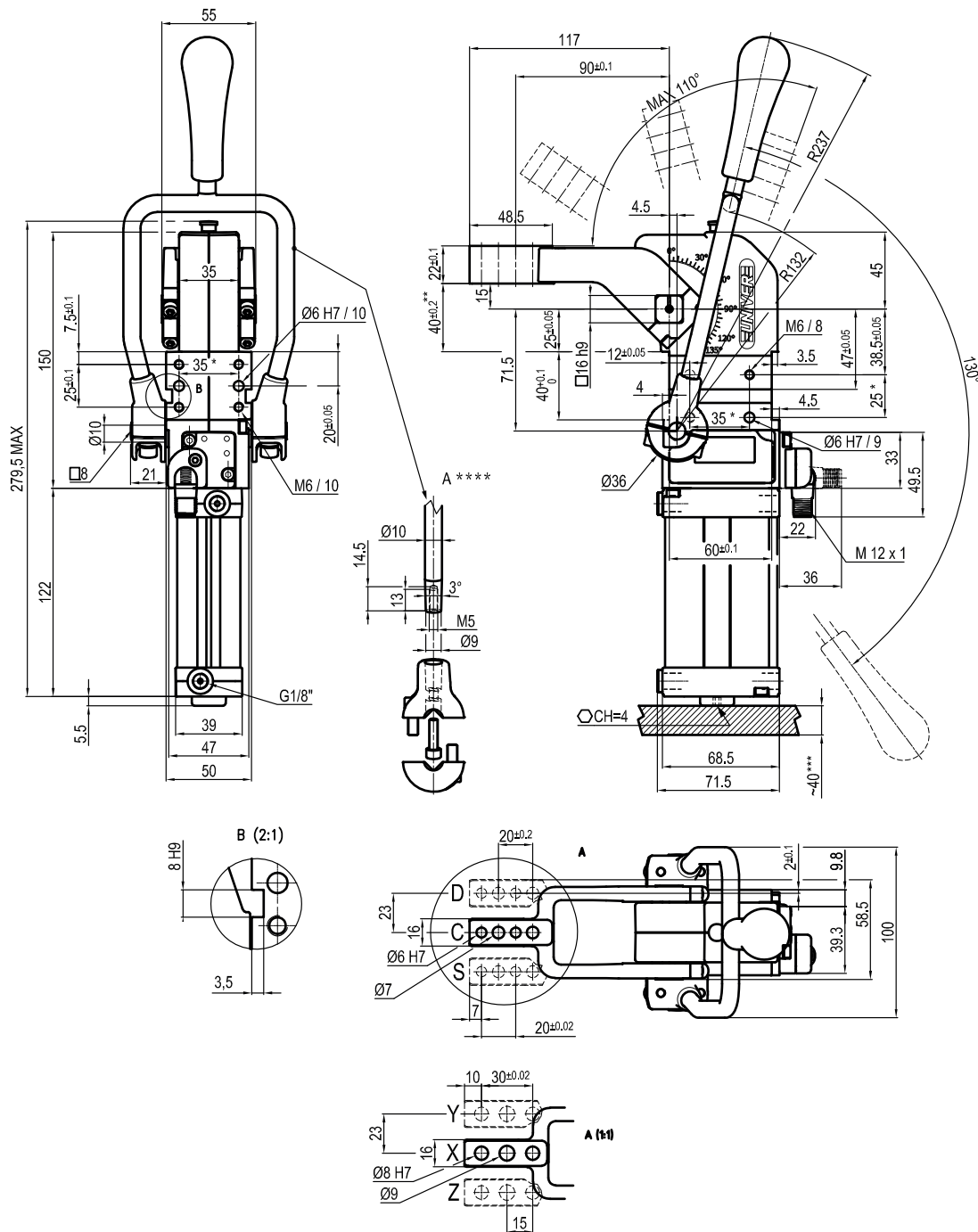

* : TOLERANCE BETWEEN DOWELS $\pm 0,02$, BETWEEN SCREW HOLES $\pm 0,1$
 ** : TOLERANCE AT 80 mm FROM PIVOT POINT
 *** : AREA TO ACCESS ANGLE ADJUSTMENT
 **** : DIMENSIONS TO BE RESPECTED IN CASE OTHER MANUAL LEVERS ARE USED

UCBT40V __ K0
6 ARM STYLE

7 ARM TYPE

6 7

 C = Central
 D = Right
 S = Left

 A = Aluminium
 S = Steel

Bore \varnothing	Holding moment	Clamping moment (0,5 MPa)	Weight (clamping arm not included)
40 mm	600 Nm	170 Nm	2,1 Kg

Min./Max. operating pressure: **0,4 / 0,6 MPa**
 Operating temperature: **5° ÷ 45° C**
 Opening angle: **adjustable from 0° to 110°**
 Arm position: **90°**
 With hand lever
 Electronic sensor with M12 swivel connector, from 0° to 90°
 Supply voltage: **10 ÷ 30 Vdc**
 IP code: **IP 65**
 Pneumatic ports on both sides

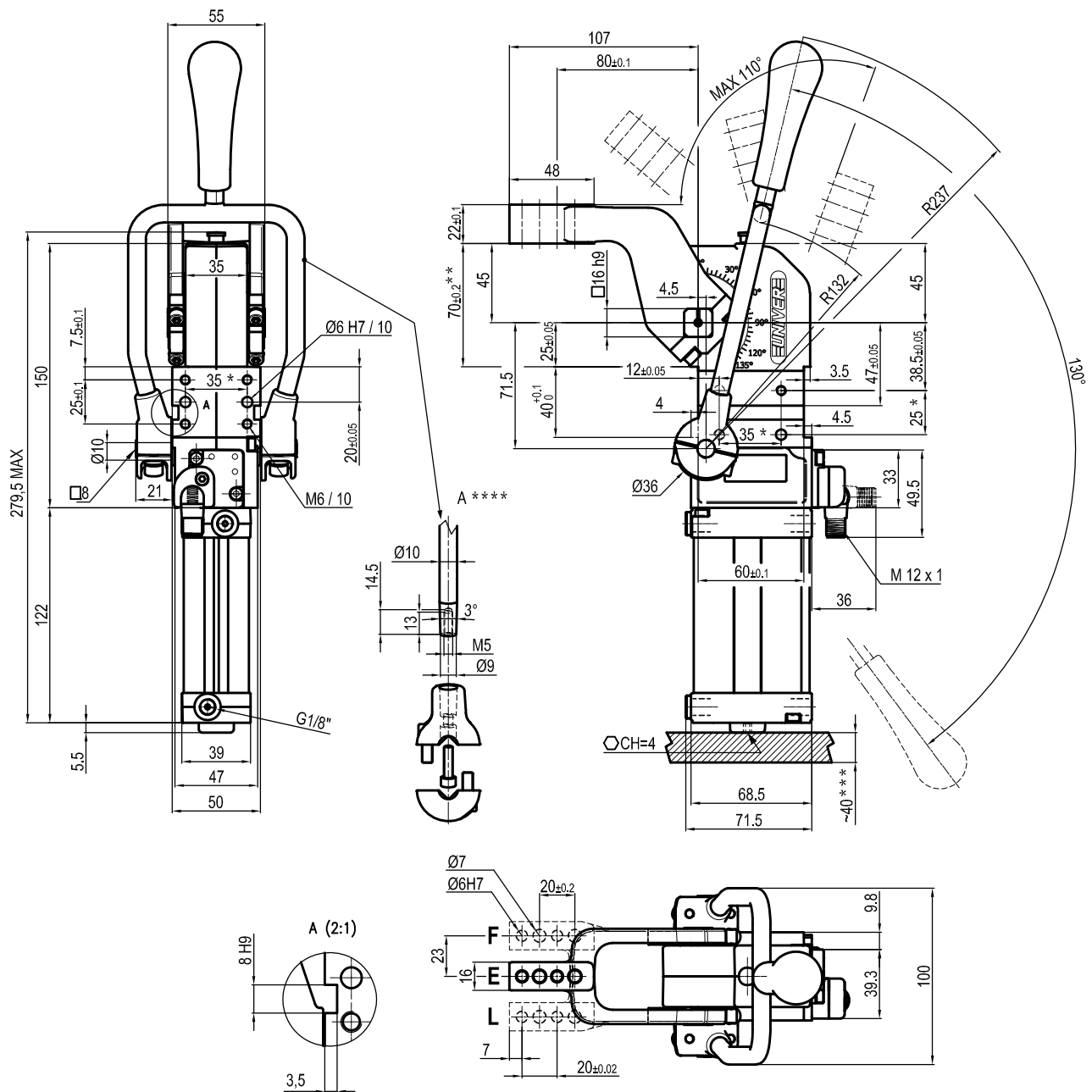

* : TOLERANCE BETWEEN DOWELS $\pm 0,02$, BETWEEN SCREW HOLES $\pm 0,1$
 ** : TOLERANCE AT 80 mm FROM PIVOT POINT
 *** : AREA TO ACCESS ANGLE ADJUSTMENT
 **** : DIMENSIONS TO BE RESPECTED IN CASE OTHER MANUAL LEVERS ARE USED

UCBT40V __ K0
6 ARM STYLE

7 ARM TYPE

6 7

 E = Central
 F = Right
 L = Left

 A = Aluminium
 S = Steel

Bore \varnothing	Holding moment	Clamping moment (0,5 MPa)	Weight (clamping arm not included)
40 mm	600 Nm	170 Nm	2,1 Kg

Min./Max. operating pressure: **0,4 / 0,6 MPa**
 Operating temperature: **5° ÷ 45° C**
 Opening angle: **adjustable from 0° to 110°**
 Arm position: **90°**
 With hand lever
 Electronic sensor with M12 swivel connector, from 0° to 90°
 Supply voltage: **10 ÷ 30 Vdc**
 IP code: **IP 65**
 Pneumatic ports on both sides