

UAGP 170

Pneumatic power pivot 170 Nm without brake

Pneumatic power pivot without brake typically used to rotate and dump fixtures and parts in a desired position.

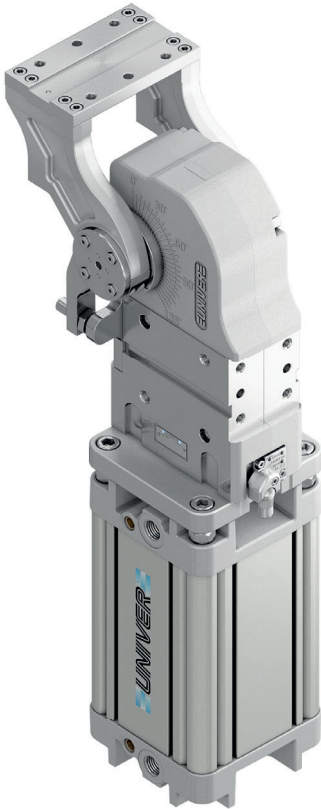

- High repeatability
- Mechanical stops
- Integrated flow control system
- Double pneumatic cushioning
- Fixing ports on 4 sides
- Tapered roller bearings to support heavy load
- Orientable table in 4 pre-set positions
- Version with brake available

CHARACTERISTICS

Operating temperature	5° ÷ 45° C
Min./Max. Operating pressure	0,4 / 0,6 MPa
Bore Ø	125 mm
Pivot rotation	45°/60°/90°/120°
Holding moment	4000 Nm
Max. torque at rotary table (0,55MPa)	170 Nm
Weight	21,3 Kg
Pneumatic supply ports	G1/2
Sensor	electronic (optical)
Supply voltage	10 ÷ 30 Vdc
IP code	IP 65

5

CODIFICATION KEY

UAG | P | 170 | O | K | 090 | W | S | O | |

1 2 3 4 5 6 7 8 9 10



OPTICAL SENSOR



FLOW CONTROL SYSTEM



HIGH REPEATABILITY

- 1 **SERIES**
UAG = UNICLAMP Power pivot
- 2 **VERSION**
P = Pneumatic
- 3 **SIZE**
170 = 170 Nm Ø 125 mm
- 4 **TABLE POSITION**
O = Horizontal 90°
P = Horizontal mirror of "O"
V = Vertical 180°
Z = Vertical mirror of "V"
*Max opening angle 60°
- 5 **SENSOR**
N = No sensor (with protection plate)
K = Electronic sensor PNP, M12 (DF-K)
Y = Electronic sensor PNP, M12 (DF-Y) white LED
J = Electronic sensor NPN, M12 (DF-J)

- 6 **PIVOT ROTATION**
120 = 120°
090 = 90°
060 = 60°
045 = 45°

- 7 **BRAKE SYSTEM**
W = Without brake

- 8 **CONNECTIONS**
S = Left side (Standard)
D = Right side
F = Front side
P = Rear side

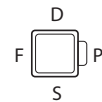

- 9 **PRODUCT REVISION**
Assigned by UNIVER

- 10 **ATEX**
X = ATEX option
See ATEX Catalogue for types and versions

Horizontal 90°

5

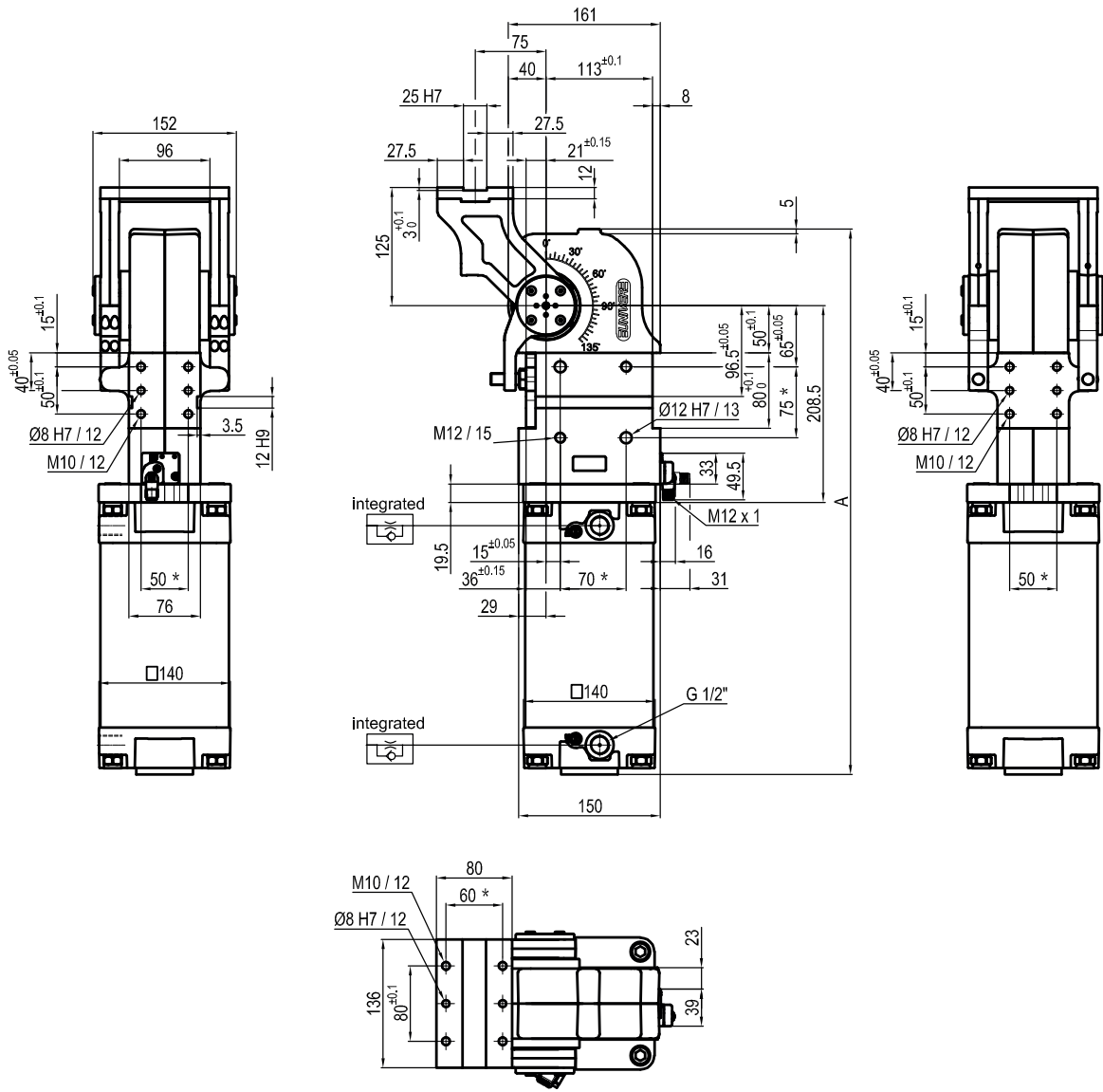

*TOLERANCE BETWEEN DOWELS $\pm 0,02$ BETWEEN SCREW HOLES $\pm 0,1$

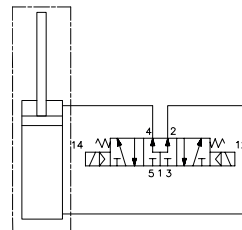

Pivot rotation (°)	A
45°	514.5
60°	526
90°	551
120°	576.5

Sensors



Electronic (optical)

- DF-K PNP M12
- DF-J NPN M12
- DF-Y PNP M12 White LED

P Horizontal
Mirror of "O" position

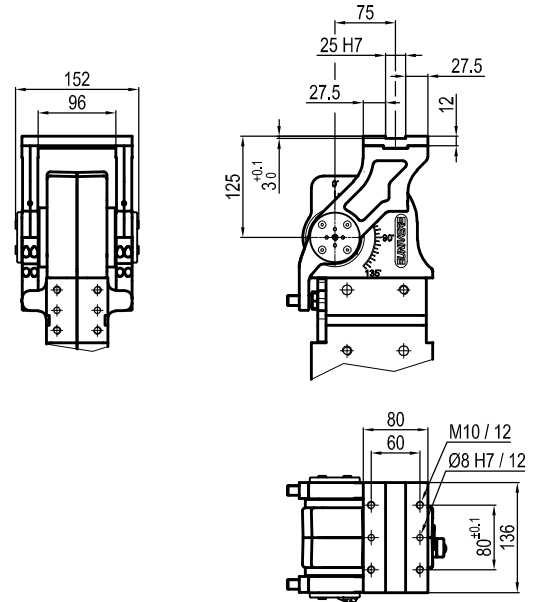

V Vertical 180°

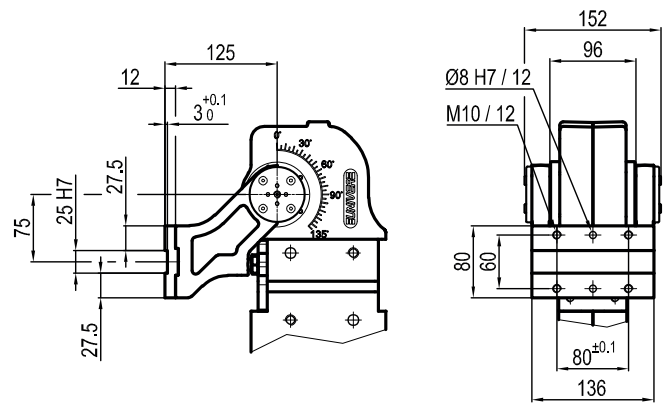

Z Vertical
Mirror of "V" position

