

UAGP 155

Pneumatic power pivot 120 Nm with brake

Pneumatic power pivot with brake typically used to rotate and dump fixtures and parts in a desired position.

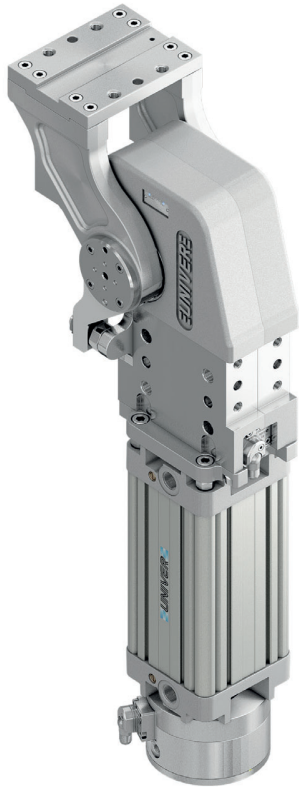

- High repeatability
- Mechanical stops
- Integrated flow control system
- Double pneumatic cushioning
- Fixing ports on 4 sides
- Tapered roller bearings to support heavy load
- Orientable table in 4 pre-set positions
- Version with sensor on the brake available

CHARACTERISTICS

Operating temperature	5° ÷ 45° C
Min./Max. Operating pressure	0,4 / 0,6 MPa
Bore Ø	100 mm
Pivot rotation	45°/60°/90°/120°
Holding moment	6000 Nm
Max. torque at rotary table (0,55MPa)	120 Nm
Weight	25 kg
Pneumatic supply ports	G1/2
Body sensor	electronic (optical)
Brake sensor	electronic
Supply voltage	10 ÷ 30 Vdc
IP code	IP 65

CODIFICATION KEY

UAG	P	155	O	A	090	B	S	0	
1	2	3	4	5	6	7	8	9	10



OPTICAL SENSOR



FLOW CONTROL SYSTEM



HIGH REPEATABILITY

1

SERIES
UAG = UNICLAMP Power pivot

2

VERSION
P = Pneumatic

3

SIZE
155 = 120 Nm Ø 100 mm

4

TABLE POSITION
O = Horizontal 90°
P = Horizontal mirror of "O"
V = Vertical 180°
Z = Vertical mirror of "V"
*Max opening angle 60°

5

SENSOR
N = No sensor (with protection plate)
K = Electronic sensor PNP, M12 (DF-K)
Y = Electronic sensor PNP, M12 (DF-Y) white LED
J = Electronic sensor NPN, M12 (DF-J)
A = Electronic sensor PNP, optical for opening angle, M12 (DF-K) + brake sensor (DF-S)

6

PIVOT ROTATION
120 = 120°
090 = 90°
060 = 60°
045 = 45°

7

BRAKE SYSTEM
B = With brake
M = With brake and manual unlock

8

CONNECTIONS
S = Left side (Standard)
D = Right side
F = Front side
P = Rear side



9

PRODUCT REVISION
Assigned by UNIVER

10

ATEX
X = ATEX option
See ATEX Catalogue for types and versions

Horizontal 90°

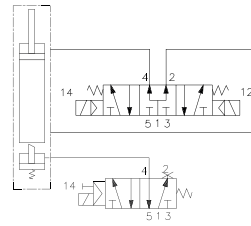
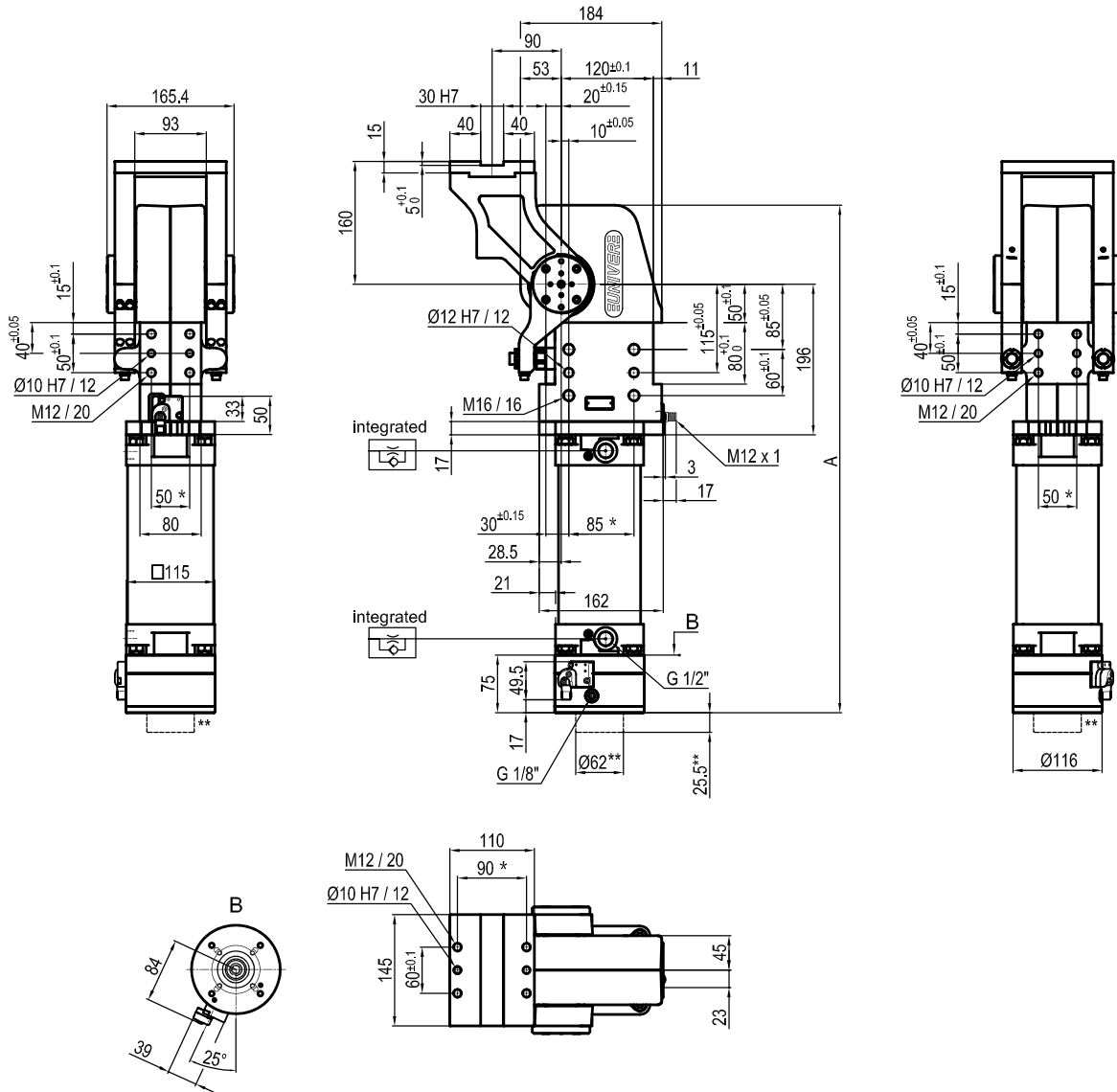

Pivot rotation (°)	A
45°	583.5
60°	597
90°	628
120°	662.5

*TOLERANCE BETWEEN DOWELS ± 0,02 BETWEEN SCREW HOLES ± 0,1
 **VERSION WITH BRAKE UNLOCK *M*

Sensors

Body



Brake



Electronic (optical)

- DF-K PNP M12
- DF-J NPN M12
- DF-Y PNP M12 White LED

Electronic

- DF-S PNP M12

P Horizontal
Mirror of "O" position

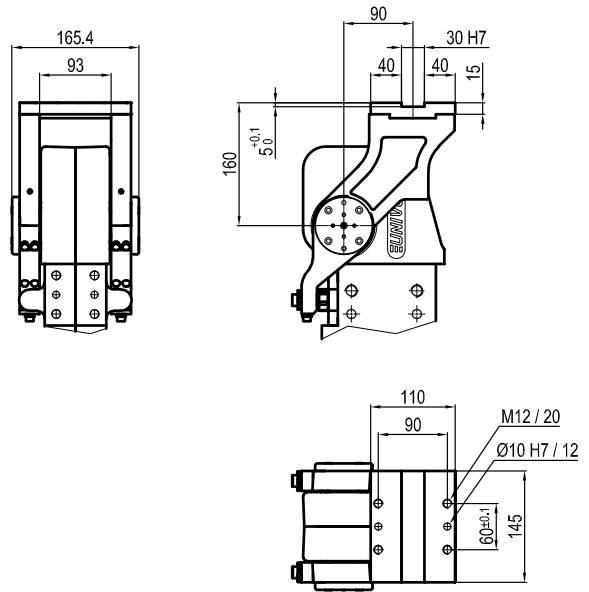

V Vertical 180°

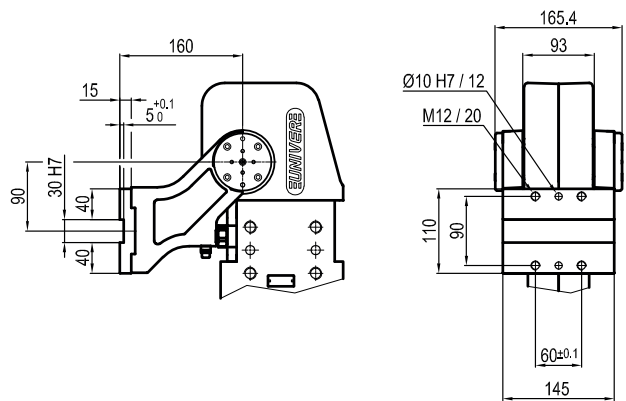

Z Vertical
Mirror of "V" position

