

DF-UPNW_

Pneumatic sensor

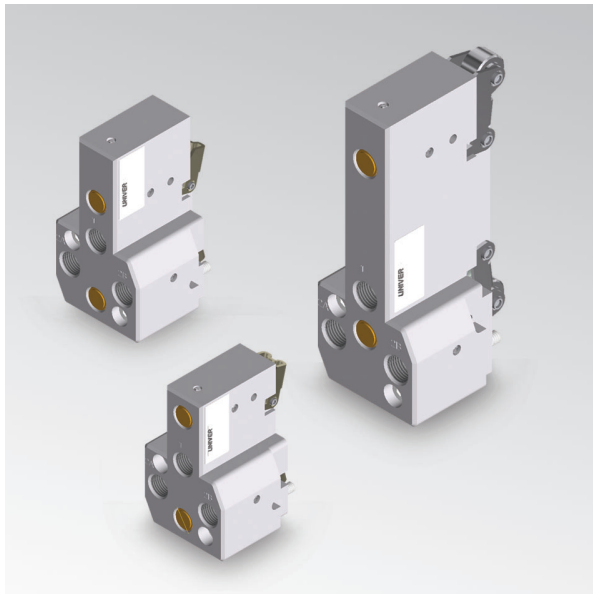

TECHNICAL CHARACTERISTICS

Output logic	N.C.
Override	mechanical
Return	mechanical spring
Supply ports	G1/8"
Ports	G1/8"
Fluid	filtered air 50um without lubrication
Pressure	4 ÷ 6 bar
Protection class	IP 65
Weight	DF-UPNWM 185 gr, DF-UPNWS 170 gr, DF-UPNW 270 gr

Dimensions

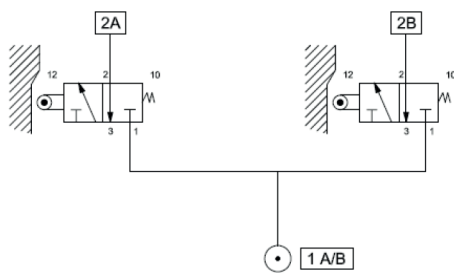
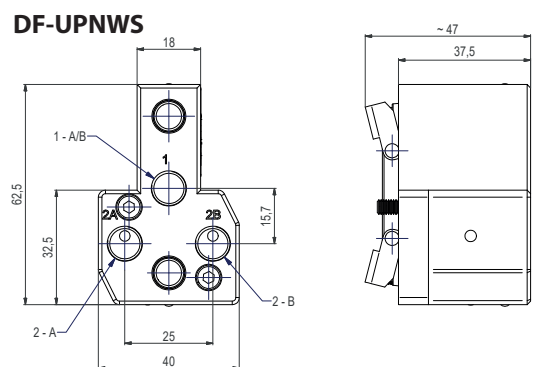
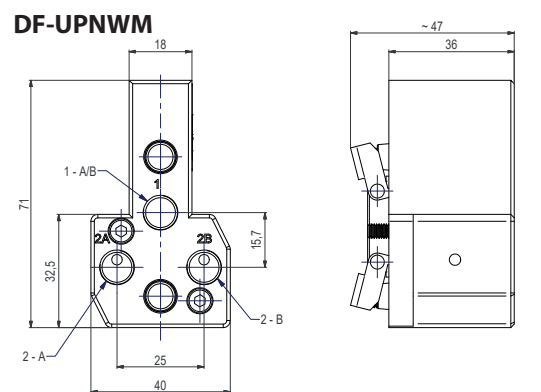
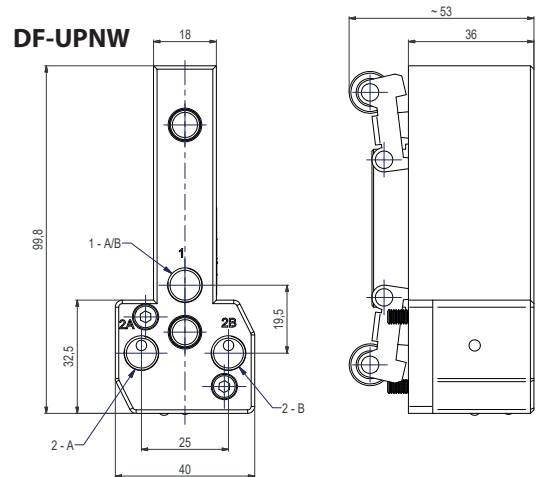

1 - A/B: A/B signals supply
 2 - A: signal CLOSE
 2 - B: signal OPEN

How to replace the sensor

- Unscrew the 2 fixing screws and replace the sensor.

