

# PM

## Ø 16 ÷ 25 mm - ISO 6432 Stainless steel pneumatic cylinders

- Stainless steel AISI 304
- Double acting versions
- Through piston rod and adjustable cushionings versions
- Execution with or without magnet

Available ATEX version upon request

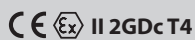

### TECHNICAL CHARACTERISTICS

Ambient temperature	0 ÷ 80 °C (-20°C with dry air)
Fluid	compressed air, filtered air, not lubricated
Working pressure	1 ÷ 10 bar
Bores	Ø 16 - 20 - 25 mm

### CONSTRUCTIVE CHARACTERISTICS

End-caps	stainless steel AISI 304
Barrel	stainless steel AISI 304
Piston	brass
Piston rod	stainless steel AISI 304
Piston seal	polyurethane
Guide bush for piston rod	sintered bronze
Shock absorber seals	neoprene
Magnet	plastroferrite
Nut	stainless steel AISI 304
O-Ring	nitrile rubber (NBR)

### CODIFICATION KEY

P	M	3	0	0	0	1	6	0	0	1	0	M	
1	2	3	4				5			6	7		

1 Series	2 Type	3 Version	4 Bore (mm)
<b>PM</b> = Ø 16 ÷ 25 mm - ISO 6432 Stainless steel pneumatic cylinders	<b>3</b> = Male piston rod	<b>00</b> = <b>D.A.</b> Standard <b>01</b> = <b>D.A.</b> Through piston rod <b>50</b> = <b>D.A.</b> With adjustable cushionings (Ø25) <b>51</b> = <b>D.A.</b> Through piston rod with adjustable cushionings (Ø25)  <b>D.A.</b> = Double acting	<b>016</b> = Ø16 <b>020</b> = Ø20 <b>025</b> = Ø25

5 Stroke (mm)	6 Magnetic	7 ATEX option
<b>0010</b> = 10 <b>0160</b> = 160 <b>0025</b> = 25 <b>0200</b> = 200 <b>0050</b> = 50 <b>0250</b> = 250 <b>0080</b> = 80 <b>0320</b> = 320 <b>0100</b> = 100 <b>0400</b> = 400 <b>0125</b> = 125 <b>0500</b> = 500	<b>M</b> = Magnetic version (standard supplied)	<b>X</b> = Atex (upon request)  <b>For types and versions please contact our Sales Office</b>

Version with high temperature seals (Max 150°C) available upon request.

Fixing elements and accessories

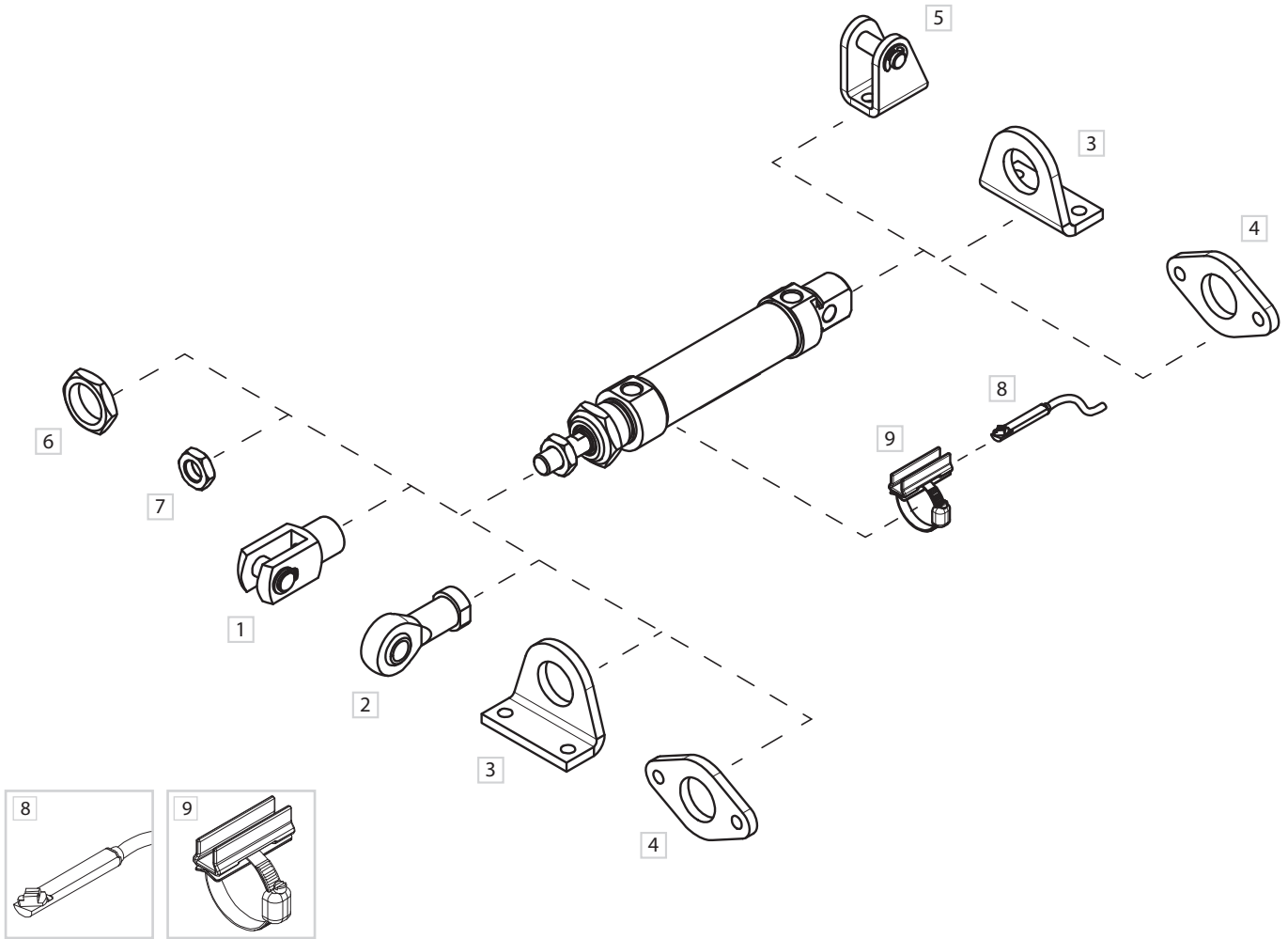

1

DESCRIPTION	NOTE	PART NO.
1 Female fork with pin	Stainless steel	MF/KF-15__PI
2 Articulated self-lubricating fork	Stainless steel	MF/KF-17__I
3 Angle bracket (MS3)	Stainless steel	MF-13__I
4 Flange (MF8)	Stainless steel	MF-12__I
5 Rear female hinge	Stainless steel	MF-21__I
6 End-cap nut	Stainless steel	MF-20__I
7 Piston rod nut	Stainless steel	MF-16__I
8 DF sensor	-	DF-P700L06
9 DF bracket and adapter	Stainless steel	DH-P__DFI

### Double acting

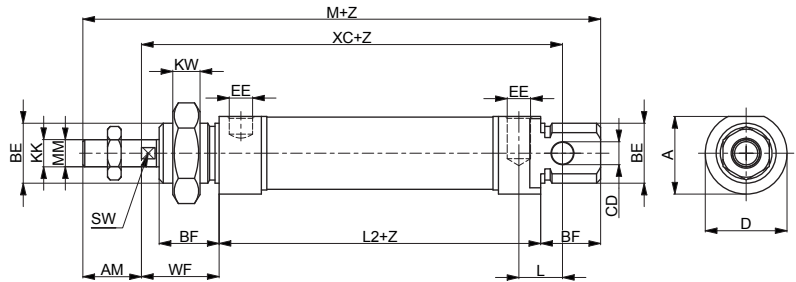
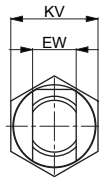

**PM300**  
D.A. Standard



**PM350**  
D.A. with adjusting cushionings

### Double acting through piston rod

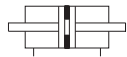

**PM301**  
D.A. Through piston rod

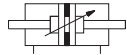

**PM351**  
D.A. Through piston rod  
with adjustable cushionings

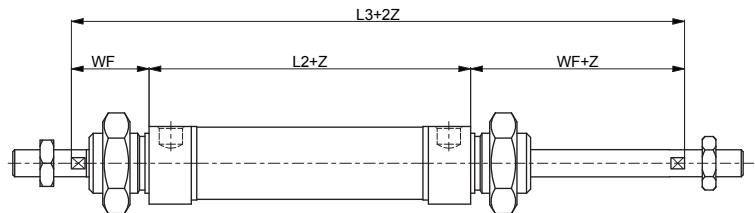

Z= Stroke

Ø	AM	A	BE	BF	CD	D	EE	EW	KK	KV
						H 9			d 13	
16	16	18	M16x1,5	18	6	19	M5x0,8	12	M6x1	22
20	20	25,5	M22x1,5	20	8	27	G1/8	16	M8x1,25	27
25	22	28,5	M22x1,5	22	8	30	G1/8	16	M10x1,25	27

Ø	KW	L	L2	L3	ØMM	M	SW	WF	XC
									± 1,2
16	8	9	53	97	6	109	5	22	82
20	11	12	67	115	8	131	7	24	95
25	11	12	68	124	10	140	9	28	104

Flange (MF8)

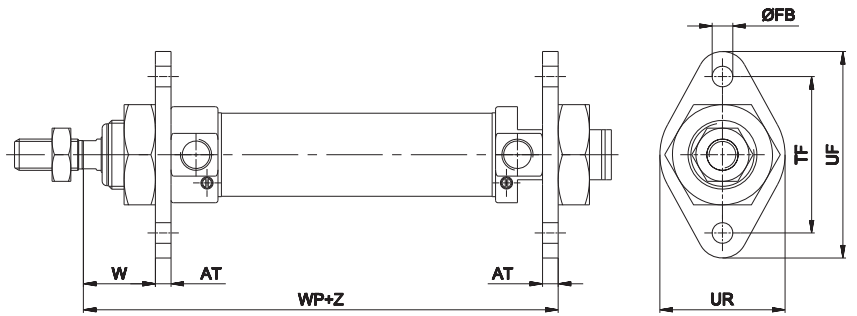
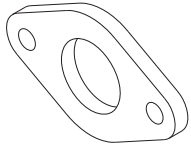

Z = Stroke

Material: Stainless steel AISI 304

Ø	AT	ØFB	TF	UF	UR	W	WP	Part no.
16	4	H13	Js14	53	30	± 1,4	79	MF-12012I
		5,5	40					
20	5	6,6	50	66	40	19	96	MF-12020I
25	5	6,6	50	66	40	23	101	

Angle bracket (MS3)

1

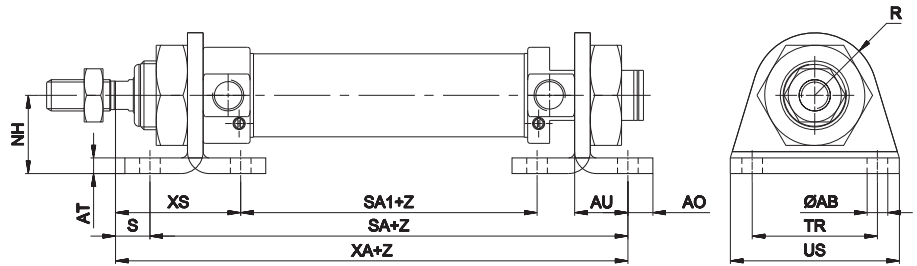
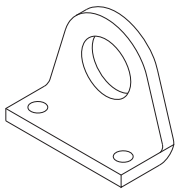

Z = Stroke

Material: Stainless steel AISI 304

Ø	AB	AO	AT	AU	NH	R	S	SA	SA1	TR	US	XA	XS	Part no.	
16	5,5	6	4	14	±0,3	±0,3	13	8	81	33	32	42	89	32	MF-13012I
20	6,6	8	5	17	25	20	7	101	43	40	54	108	36	MF-13020I	
25	6,6	8	5	17	25	20	11	102	44	40	54	113	40		

Rear female hinge

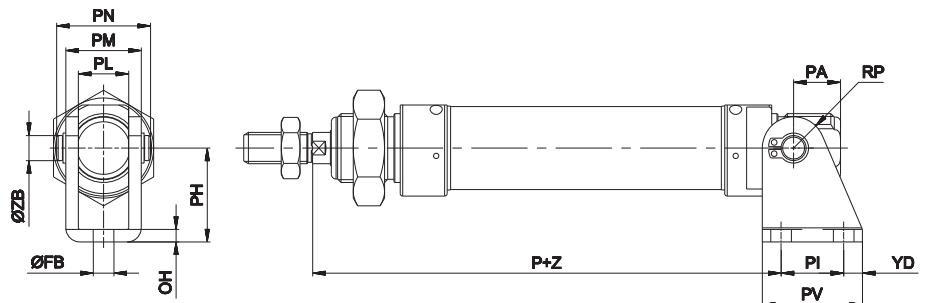
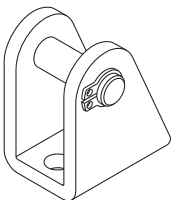

Z = Stroke

Including bolt and 2 circlips

Material: Stainless steel AISI 304

Ø	FB	OH	P	PA	PH	PI	PL	PM	PN	PV	RP	YD	ZB	Part no.
16	5,5	3	80	13	27	15	12,1	18,1	23	25	7	5	6	MF-21012I
20	6,6	4	91	16	30	20	16,1	24,1	30	32	10	6	8	MF-21020I
25	6,6	4	100	16	30	20	16,1	24,1	30	32	10	6	8	

**Female fork with pin**

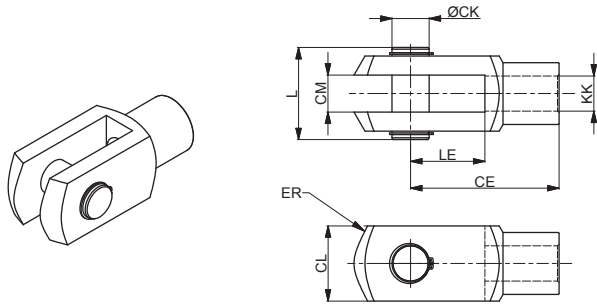

Material: Stainless steel AISI 303 (Ø16-20) 304 (Ø25)

Ø	CE	CK	CL	CM	ER	KK	L	LE	Part no.
									B12
16	24	6	12	6	7	M6x1	16	12	MF-15012PI
20	32	8	16	8	10	M8x1,25	22	16	MF-15020PI
25	40	10	20	10	16	M10x1,25	26	20	KF-15032PI

**Articulated self-lubricating fork**

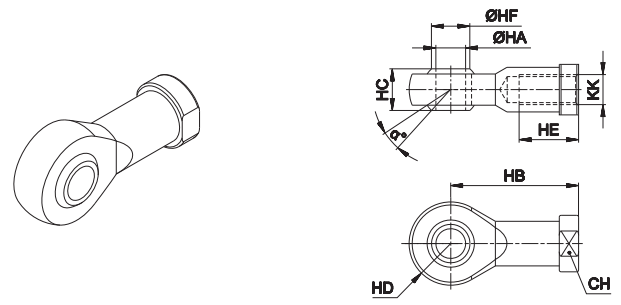

Material: Stainless steel AISI 303 (Ø16-20) 304 (Ø25)

Ø	α°	CH	KK	HA	HB	HC	HD	HE	HF	Part no.
										H7
16	13°	11	M6x1	6	30	9	10	12	9	MF-17012I
20	14°	14	M8x1,25	8	36	12	12	16	10,4	MF-17020I
25	13°	17	M10x1,25	10	43	14	14	20	12,9	KF-17032I

**Piston rod nut**



Material: Stainless steel AISI 304

Ø	KK	KV	KW	Part no.
16	M6x1	10	4	MF-16012I
20	M8x1,25	13	5	MF-16020I
25	M10x1,25	17	6	KF-16032I

**End-cap nut**



Material: Stainless steel AISI 303

Ø	BE	KV1	KW1	Part no.
16	M16x1,5	24	8	MF-20012I
20	M22x1,5	32	10	MF-20020I

**DF bracket**

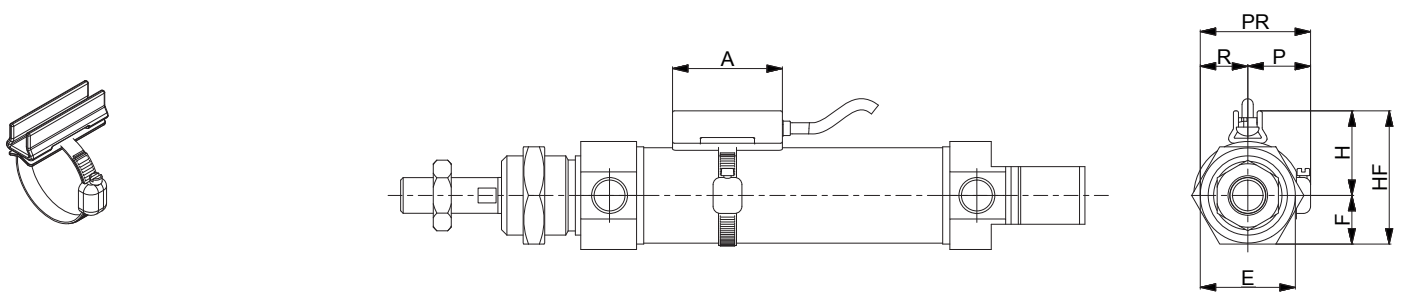

Material: Stainless steel AISI 303

Ø	A	E	F	H	HF	P	R	PR	Part no.
16	34	22	11	18	29	17	11	28	DH-P016020DFI
20	34	24	12	20	32	17	12	29	
25	34	32	16	23	39	19	16	35	DH-P025032DFI

For DF sensors see accessories section

**DF sensor**

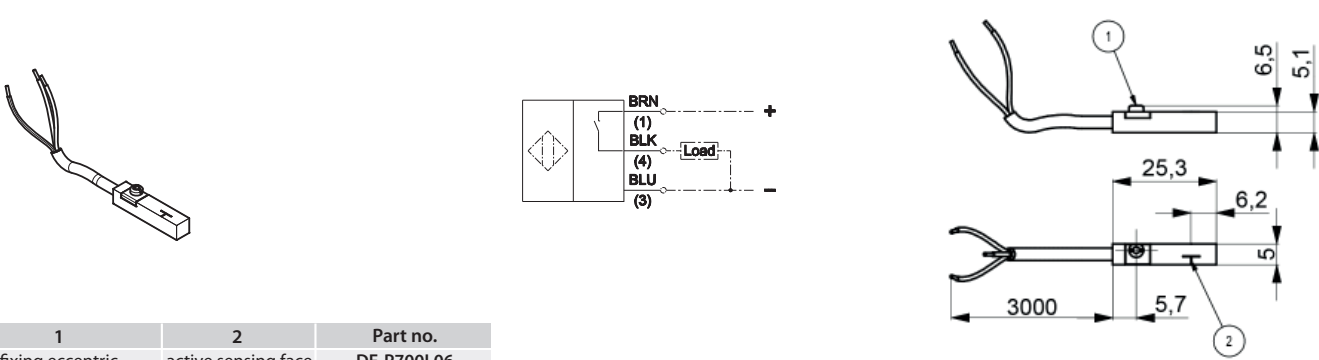

1	2	Part no.
fixing eccentric	active sensing face	DF-P700L06



# PM

## Ø 32 ÷ 63 mm - Stainless steel pneumatic cylinders

- Stainless steel AISI 304
- Double acting versions
- Through piston rod versions
- Execution with or without magnet



### TECHNICAL CHARACTERISTICS

Ambient temperature	0 ÷ 80 °C (-20°C with dry air)
Fluid	compressed air, filtered air, not lubricated
Working pressure	1 ÷ 10 bar
Bores	Ø 32 - 40 - 50 - 63 mm

### CONSTRUCTIVE CHARACTERISTICS

End-caps	stainless steel AISI 304
Barrel	stainless steel AISI 304
Piston	aluminium
Guide slide	PBT+PTFE
Piston rod	stainless steel AISI 316
Piston seal	polyurethane
Guide bush for piston rod	sintered bronze
Shock absorber seals	neoprene
Magnet	plastoferrite
Nut	stainless steel AISI 304
O-Ring	nitrile rubber (NBR)

### CODIFICATION KEY

P	M	3	0	0	0	3	2	0	0	5	0	M
1	2	3	4		5			6				

1 Series	2 Type	3 Version	4 Bore (mm)
PM = Ø 32 ÷ 63 mm Stainless steel pneumatic cylinders	3 = Male piston rod	00 = D.A. Standard 01 = D.A. Through piston rod D.A. = Double acting	032 = Ø32 040 = Ø40 050 = Ø50 063 = Ø63

5 Stroke (mm)	6 Magnetic
0010 = 10    0160 = 160 0025 = 25    0200 = 200 0050 = 50    0250 = 250 0080 = 80    0320 = 320 0100 = 100    0400 = 400 0125 = 125    0500 = 500	M = Magnetic version (standard supplied)

Version with high temperature seals (Max 150°C) available upon request.

Fixing elements and accessories

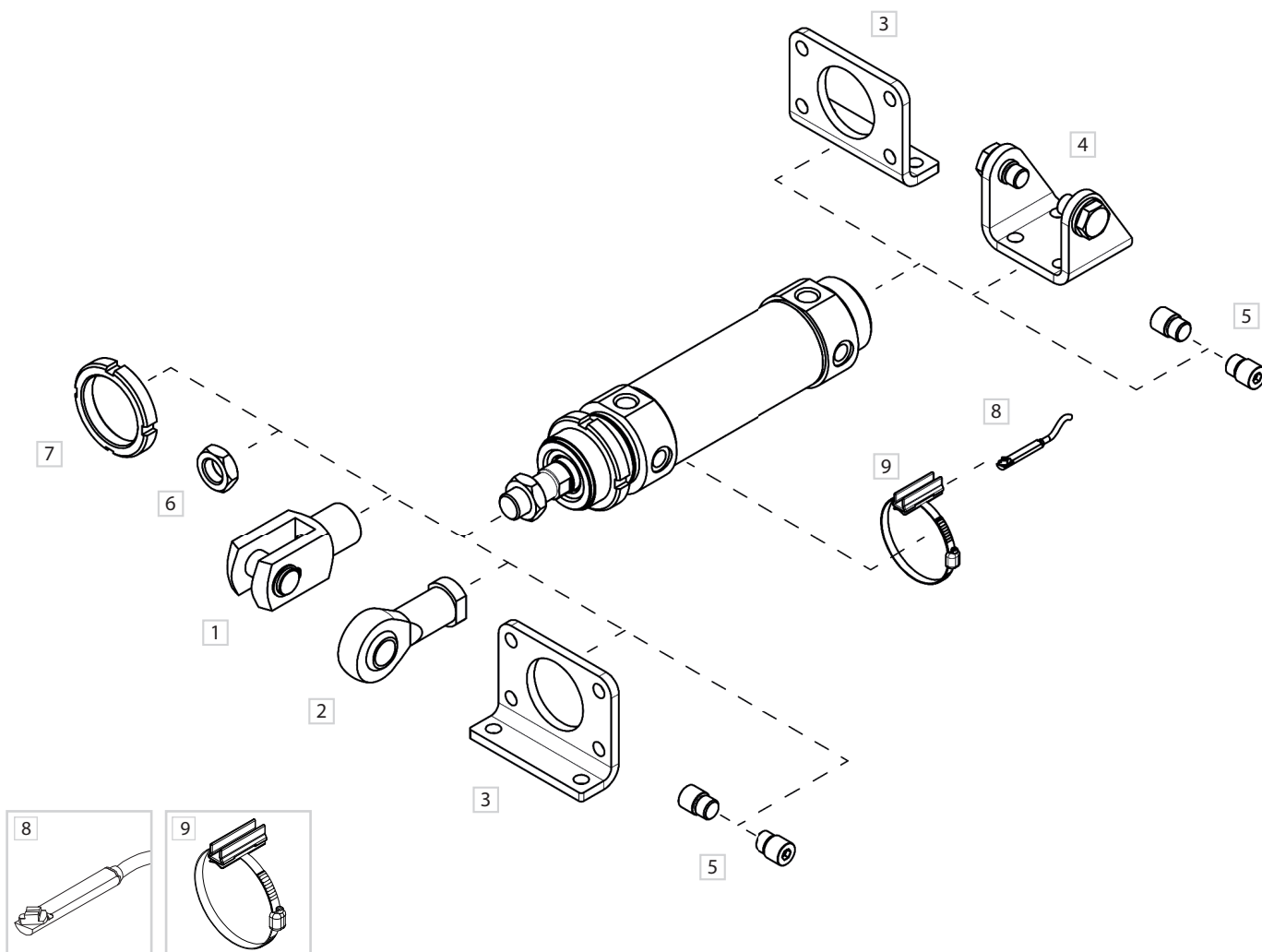

DESCRIPTION	NOTE	PART NO.
1 Female fork with pin	Stainless steel	MF/KF-15 __ _PI
2 Articulated self-lubricating fork	Stainless steel	MF/KF-17 __ _I
3 Angle bracket/Flange	Stainless steel	MF-13 __ _I
4 Female hinge with screws	Stainless steel	MF-21 __ _I
5 Pins (pair)	Stainless steel	MF-18 __ _I
6 Piston rod nut	Stainless steel	MF-16 __ _I
7 Nut	Stainless steel	MF-20 __ _I
8 DF sensor	-	DF-P700L06
9 DF bracket and adaptor	Stainless steel	DH-P __ _DFI



### Double acting

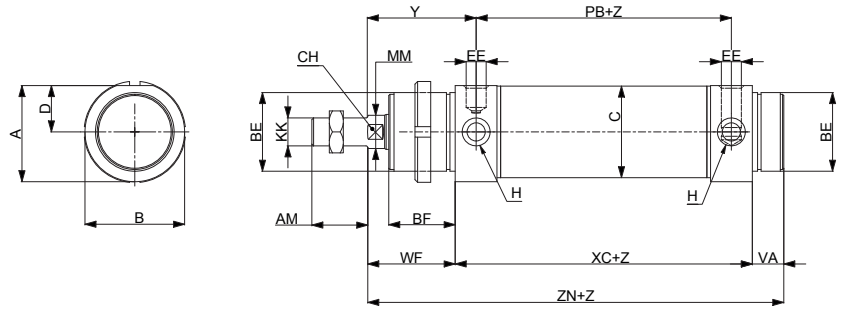

**PM300**  
D.A. Standard

### Double acting through piston rod

**PM301**  
D.A. Through piston rod

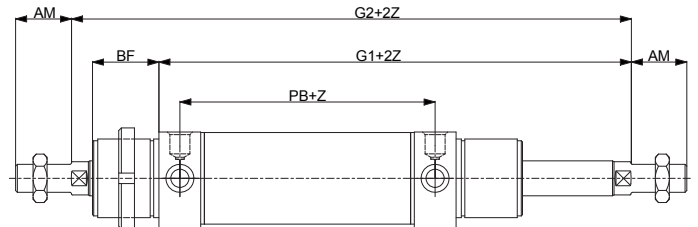

Z= Stroke

Ø	A	AM	ØB	BE	BF	C	CH	D	EE	H
32	36,5	20	38	M30x1,5	30	33,6	10	17,5	G1/8	M30x1,5
40	44	24	46	M38x1,5	35	41,6	13	21	G1/4	M38x1,5
50	55	32	57	M45x1,5	38	52,4	17	26,5	G1/4	M45x1,5
63	67,5	32	70	M45x1,5	38	65,4	17	32,5	G3/8	M45x1,5
Ø	KK	ØMM	PB	VA	WF	XC	Y	ZN	G1	G2
32	M10x1,25	12	78	14	38	96	47	148	134	172
40	M12x1,25	16	89	16	45	113	57	174	158	203
50	M16x1,5	20	96	18	50	120	62	188	170	220
63	M16x1,5	20	98	18	50	124	63	192	174	224

Pins

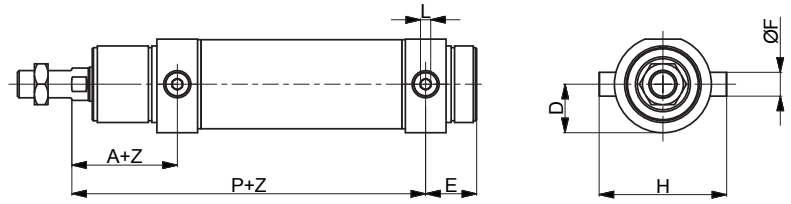

Material: Stainless steel AISI 304

Z = Stroke

Ø	A	P	E	L	D	H	ØF	Part no.
32	47	125	23	5	19	51	10	MF-18032I
40	57	146	28	6	23	61	12	MF-18040I
50	62	158	30	6	28,5	75	14	MF-18050I
63	63	161	31	8	35	92	16	MF-18063I

Angle bracket/Flange

1

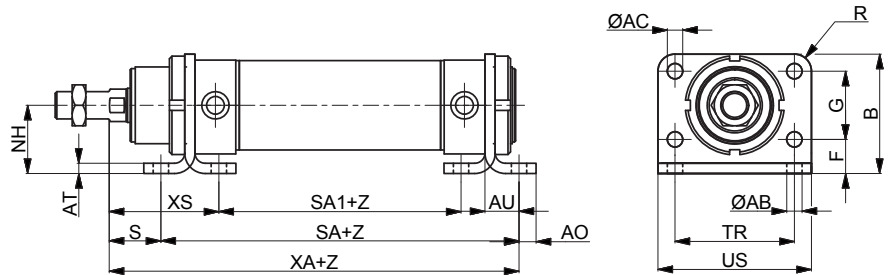
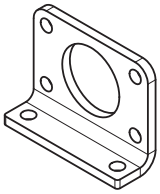

Material: Stainless steel AISI 304

Z = Stroke

Ø	NH	AT	XS	S	SA	SA1	XA	AU	AO	ØAC	R	US	TR	ØAB	F	G	B	Part no.
32	28	4	52	24	124	68	148	14	7	7	7	66	52	7	14	28	49	MF-13032I
40	33	5	65	25	153	73	178	20	10	9	10	80	60	9	18	30	58	MF-13040I
50	40	6	70	30	160	80	190	20	10	9	10	90	70	9	20	40	70	MF-13050I
63	45	6	70	30	164	84	194	20	10	9	10	96	76	9	20	50	80	MF-13063I

Female hinge with screws

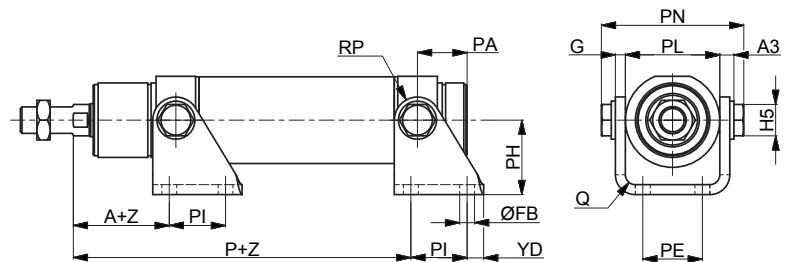
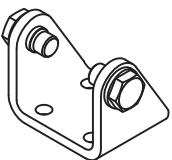

Including bolt and 2 circlips

Material: Stainless steel AISI 304

Z = Stroke

Ø	A	P	PI	ØFB	YD	PH	RP	PA	G	PN	PL	A3	H5	PE	Q	Part no.
32	45	120	24	7	8	35	12	20	4	54,1	38,1	6	13	20	4	MF-21032I
40	55	141	30	9	10	40	13	27	5	65,1	46,1	7	17	28	5	MF-21040I
50	59	152	34	9	10	45	14	30	6	80,1	57,1	8,5	19	36	6	MF-21050I
63	60	155	35	9	15	50	16	34	6	93,1	70,1	8,5	19	42	6	MF-21063I

**Female fork with pin**

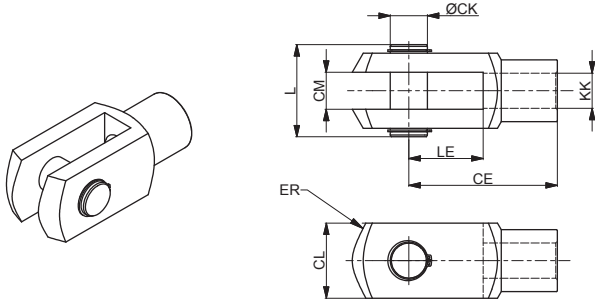

Material: Stainless steel AISI 304

Ø	CE	CK	CL	CM	ER	KK	L	LE	Part no.
32	40	10	20	10	16	M10x1,25	26	20	KF-15032PI
40	48	12	24	12	19	M12x1,25	32	24	KF-15040PI
50	64	16	32	16	25	M16x1,5	40	32	KF-15050PI
63									

**Articulated self-lubricating fork**

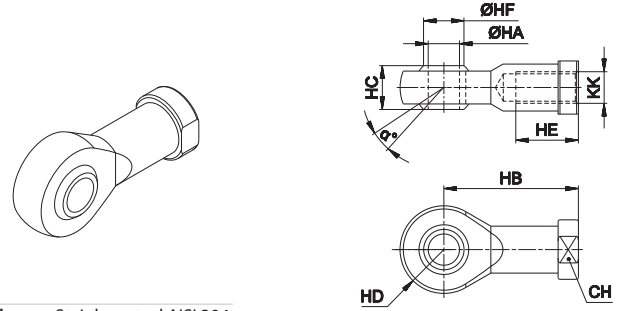

Material: Stainless steel AISI 304

Ø	α°	CH	KK	HA	HB	HC	HD	HE	HF	Part no.
32	13	17	M10x1,25	10	43	14	14	20	12,9	KF-17032I
40	13	19	M12x1,25	12	50	16	16	22	15,4	KF-17040I
50	15	22	M16x1,5	16	64	21	21	28	19,3	KF-17050I
63										

**Nut for end-cap**

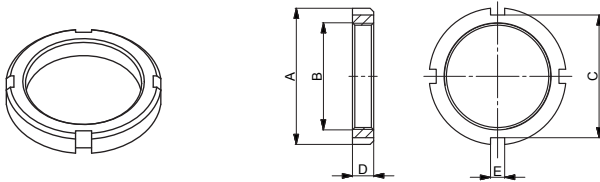

Material: Stainless steel AISI 304

Ø	A	B	C	D	E	Part no.
40	50	M38x1,5	46	8	5	MF-20040I
50	58	M45x1,5	52	9	6	MF-20050I
63	58	M45x1,5	52	9	6	MF-20063I

**Piston rod nut**



Material: Stainless steel AISI 304

Ø	KK	KV	KW	Part no.
40	M12x1,25	19	7	KF-16040I
50	M16x1,5	24	8	KF-16050I
63				

**DF bracket**

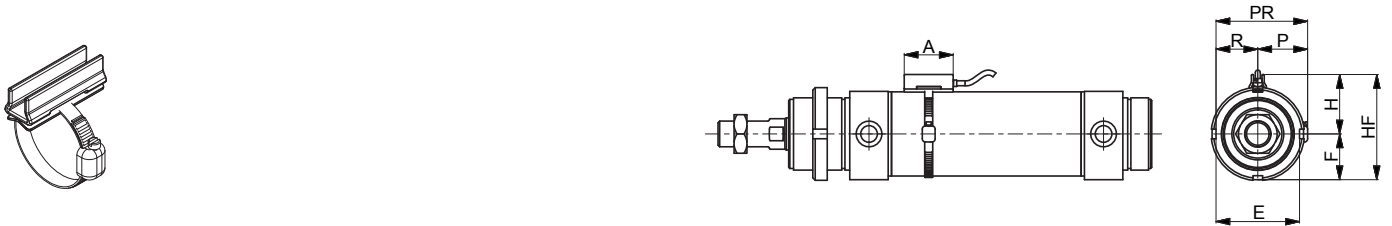

Material: Stainless steel AISI 303

Ø	A	E	F	H	HF	P	R	PR	Part no.
40	34	41,5	20,75	53	94,5	47	41,5	88,5	DH-P040DFI
50	34	51,5	25,75	63	114,5	57	51,5	108,5	DH-P050DFI
63	34	64,5	32,25	76	140,5	70	64,5	134,5	DH-P063DFI

For DF sensors see accessories section

**DF sensor**



1	2	Part no.
fixing eccentric	active sensing face	DF-P700L06

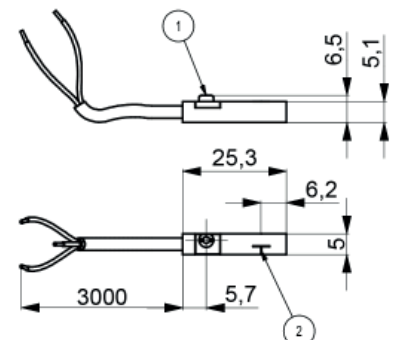



# PK

## ISO 15552 Stainless steel pneumatic cylinders - Ø 32 ÷ 125 mm

- Stainless steel AISI 316
- Double acting versions
- Through piston rod versions
- FDA approved piston seals
- Execution with or without magnet

Available ATEX version upon request

CE II 2GDc T4



### TECHNICAL CHARACTERISTICS

Ambient temperature	0 ÷ 80 °C (-20°C with dry air) 0 ÷ 150 °C (with high temperature seals)
Fluid	compressed air, filtered air, not lubricated
Working pressure	1 ÷ 10 bar
Bores	Ø 32 - 40 - 50 - 63 - 80 - 100 - 125 mm
Cushionings	adjustable on both sides

### CONSTRUCTIVE CHARACTERISTICS

End-caps	stainless steel AISI 316
Barrel	stainless steel AISI 316
Piston	die-cast aluminium
Guide slide	PBT+PTFE
Piston rod	stainless steel AISI 316
Piston seal	polyurethane
Guide bush for piston rod	sintered bronze
Magnet	plastroferrite
O-Ring	nitrile rubber (NBR)
Tie-rods	stainless steel AISI 316

### CODIFICATION KEY

P	K	3	0	0	0	3	2	0	0	2	5	M	
1	2	3	4			5			6	7			

1 Series	2 Type	3 Version	4 Bore (mm)
PK = Pneumatic cylinders ISO 15552 Ø 32 ÷ 125 mm	3 = Stainless steel piston rod	00 = D.E. Standard 01 = D.E. Through-rod  D.E. = Double effect	032 = Ø32 080 = Ø80 040 = Ø40 100 = Ø100 050 = Ø50 125 = Ø125 063 = Ø63

5 Stroke (mm)	6 Magnetic	7 ATEX option
0025 = 25 0150 = 150 0320 = 320 0600 = 600 0850 = 850 0050 = 50 0160 = 160 0400 = 400 0650 = 650 0900 = 900 0080 = 80 0200 = 200 0450 = 450 0700 = 700 0950 = 950 0100 = 100 0250 = 250 0500 = 500 0750 = 750 1000 = 1000 0125 = 125 0300 = 300 0550 = 550 0800 = 800	M = Magnetic version (standard supplied)	X = ATEX (upon request)

Version with high temperature seals (Max 150°C) available upon request.

Fixing elements and accessories

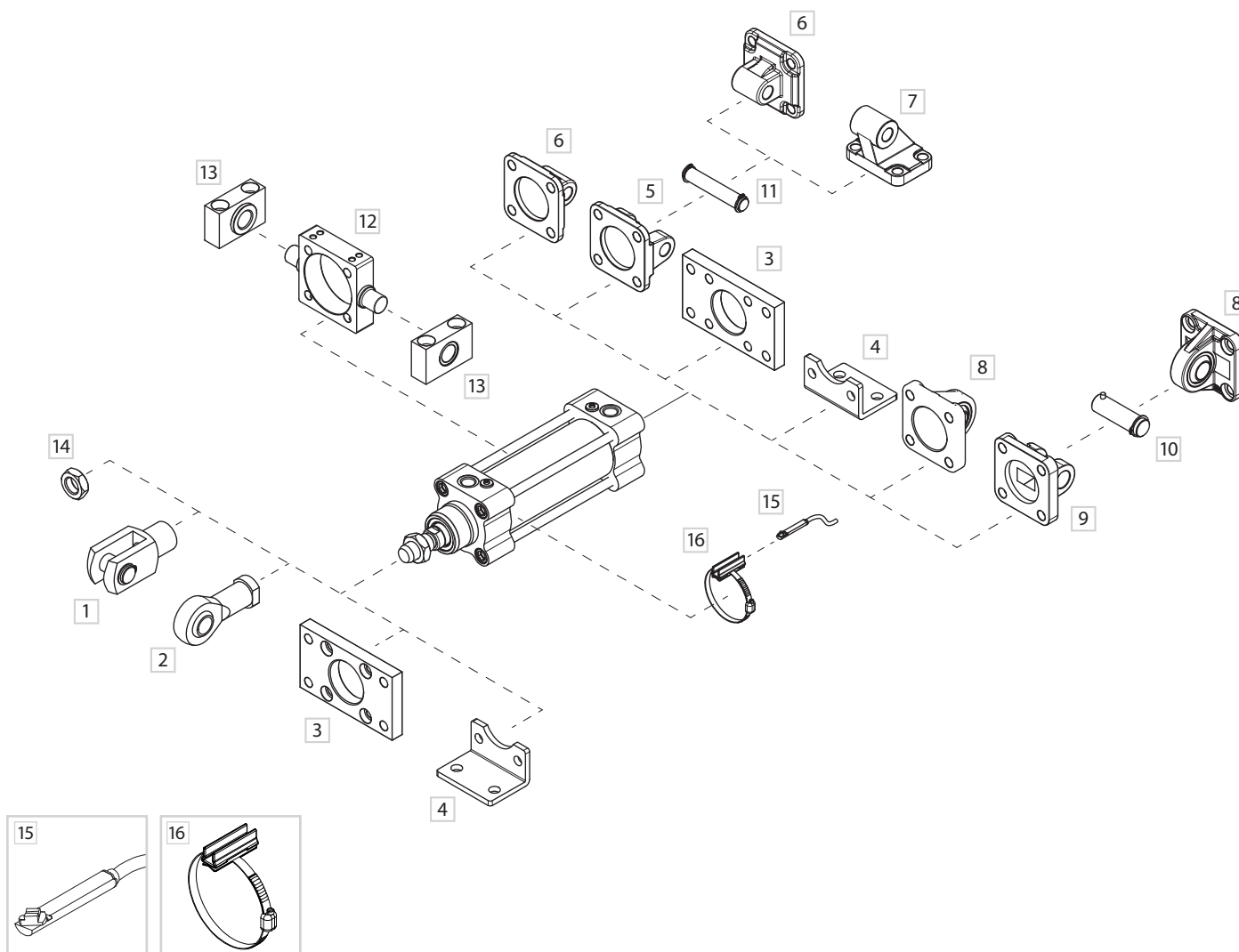

DESCRIPTION	NOTE	PART NO.
1 Female fork with pin	Stainless steel	KF-15 __ _PI
2 Articulated self-lubricating fork	Stainless steel	KF-17 __ _I
3 Front/rear flange (ISO MF1-MF2)	Stainless steel	KF-12 __ _I
4 Angle bracket (ISO MS1)	Stainless steel	KF-13 __ _I
5 Female hinge (ISO MP2)	Stainless steel	KF-10 __ _AI
6 Rear male hinge (ISO MP4)	Stainless steel	KF-11 __ _I
7 Counter hinge 90° (CETOP RP107P)	Stainless steel	KF-19 __ _CTAI
8 Articulated rear male hinge (ISO MP6)	Stainless steel	KF-11 __ _SI
9 Narrow female hinge with pin (DIN648K)	Stainless steel	KF-10 __ _ASI/
10 Narrow hinge pin (DIN648K)	Stainless steel	KF-18S I
11 Female hinge pin (ISO MS1)	Stainless steel	KF-18 _I
12 Intermediate hinge for tie-rods	Stainless steel	KF-14 __ _TI
13 Hinge support	Stainless steel	KF-41 __ _I
14 Piston rod nut	Stainless steel	KF-16 __ _I
15 DF sensor	-	DF-P700L06
16 DF bracket and adapter	Stainless steel	DH-P __ _DFI

### Double acting

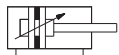
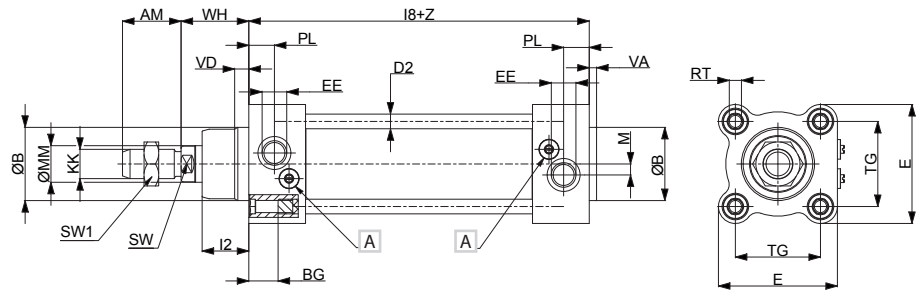

**PK300**  
D.A. Standard

### Double acting through piston rod

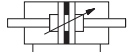

**PK301**  
D.A. Through piston rod

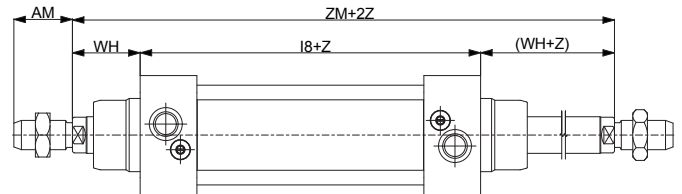

Z= Stroke

Ø	AM	ØB	BG	E	KK	I2	I8	PL	RT	SW	TG	VA	VD	WH	ØMM	EE	M	SW1	D2	ZM
32	22	30	16	48	M10x1,25	18	94 ±0,4	13	M6	10	32,5 ±0,5	4	5	26	12	G1/8	5,3	17	6	146
40	24	35	16	52	M12x1,25	22	105 ±0,7	14	M6	13	38 ±0,5	4	5	30	16	G1/4	5	19	6	165
50	32	40	16	65	M16x1,5	25,5	106 ±0,7	14	M8	17	46,5 ±0,6	4	6	37	20	G1/4	6	24	8	180
63	32	45	16	75	M16x1,5	26	121 ±0,8	16	M8	17	56,5 ±0,7	4	6	37	20	G3/8	6,5	24	8	195
80	40	45	18	95	M20x1,5	32	128 ±0,8	16	M10	22	72 ±0,7	4	7	46	25	G3/8	8	30	10	220
100	40	55	18	115	M20x1,5	38	138 ±1	18	M10	22	89 ±0,7	4	7	51	25	G1/2	7	30	10	240
125	54	60	20	140	M27x2	46	160 ±1	18	M12	27	110 ±1,1	6	10	65	32	G1/2	7	41	12	290

A Adjusting screw for pneumatic cushioning

Female hinge (ISO MP2) with pin

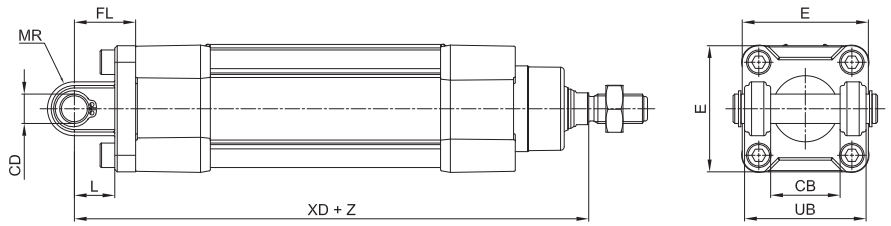
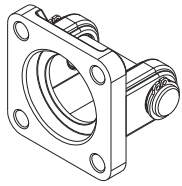

Material: Stainless steel AISI 304

Z = Stroke

Ø	CB	CD	E	FL	L	MR	UB	XD		Part no.
	H14	H9		± 0,2	min	Max	h14			
32	26	10	48	22	12	11	45	142	±1,25	KF-10032AI
40	28	12	54	25	15	13	52	160	±1,25	KF-10040AI
50	32	12	65	27	15	13	60	170	±1,25	KF-10050AI
63	40	16	75	32	20	17	70	190	±1,6	KF-10063AI
80	50	16	95	36	20	17	90	210	±1,6	KF-10080AI
100	60	20	115	41	25	21	110	230	±1,6	KF-10100AI
125	70	25	140	50	30	26	130	275	±2	KF-10125AI

Narrow female hinge with pin (DIN648K)

1

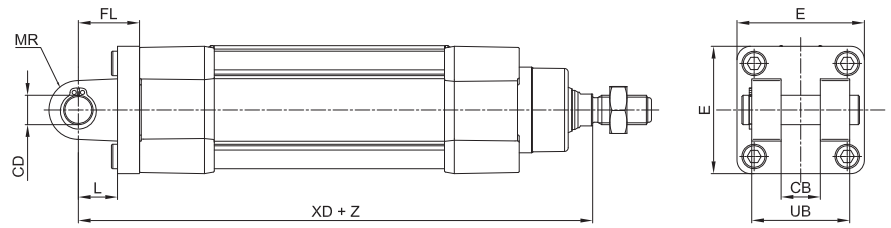
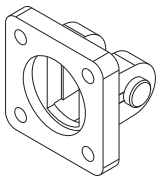

Material: Stainless steel AISI 316

Z = Stroke

Ø	CB	CD	E	FL	L	MR	UB	XD		Part no.
	H14	H9		± 0,2	min	Max	h14			
32	14	10	45	22	10	10	34	142	±1,25	KF-10032ASI
40	16	12	52	25	16	12	40	160	±1,25	KF-10040ASI
50	21	16	65	27	16	14	45	170	±1,5	KF-10050ASI
63	21	16	75	32	21	18	51	190	±1,6	KF-10063ASI
80	25	20	95	36	22	20	65	210	±1,6	KF-10080ASI
100	25	20	115	41	27	22	75	230	±1,6	KF-10100ASI
125	37	30	140	50	30	25	97	275	±2	KF-10125ASI

Female hinge pin

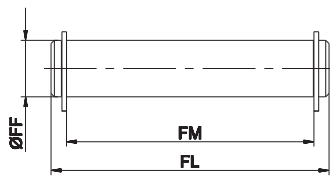

Including 2 circlips

Material: Stainless steel AISI 304

Ø	FF	FL	FM	Part no.
32	f8	53	46	KF-18032I
40	12	61,3	53	KF-18040I
50	12	69	61	KF-18050I
63	16	80,5	71	KF-18063I
80	16	100,5	91	KF-18080I
100	20	122,5	111	KF-18100I
125	25	140	131	KF-18125I

Narrow female hinge pin

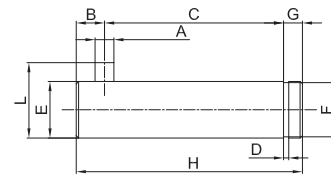

Including 2 circlips

Material: Stainless steel AISI 316

Ø	A	C	D	E	F	G	H	L	B	Part no.
	H12	<sup>+0,5</sup> / <sub>+0,3</sub>	h13	f7	h11			<sup>0</sup> / <sub>-0,5</sub>		
32	3	32,5	1,1	10	9,6	4	41	14	4,5	KF-18032SI
40	4	38	1,1	12	11,5	4	48	16	6	KF-18040SI
50	4	43	1,1	16	15,2	5	54	20	6	KF-18050SI
63	4	49	1,1	16	15,2	5	60	20	6	KF-18063SI
80	4	63	1,3	20	19	6	75	24	6	KF-18080SI
100	4	73	1,3	20	19	6	85	24	6	KF-18100SI
125	6	94	1,6	30	28,6	7	110	36	9	KF-18125SI



Rear male hinge (ISO MP4)

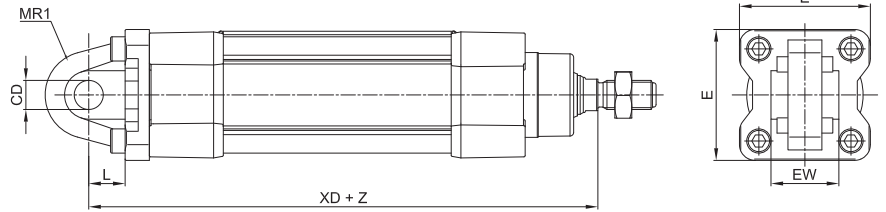
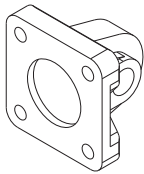

Material: Stainless steel AISI 304

Z = Stroke

Ø	CD	E	EW		L	MR1	XD		Part no.
	H9				min				
32	10	48	26	-0,2 / -0,6	12	15*	142	±1,25	KF-11032I
40	12	54	28	-0,2 / -0,6	15	18*	160	±1,25	KF-11040I
50	12	65	32	-0,2 / -0,6	15	20*	170	±1,25	KF-11050I
63	16	75	40	-0,2 / -0,6	20	23*	190	±1,6	KF-11063I
80	16	95	50	-0,2 / -0,6	20	27*	210	±1,6	KF-11080I
100	20	115	60	-0,2 / -0,6	25	29,5*	230	±1,6	KF-11100I
125	25	140	70	-0,5 / -1,2	30	26	275	±2	KF-11125I

\* = Non-standard dimension

Articulated rear male hinge (ISO MP6)

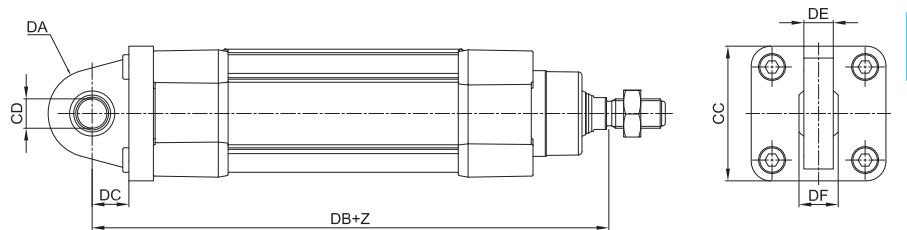
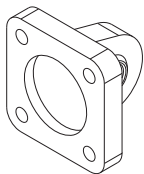

Material: Stainless steel AISI 316

Z = Stroke

Ø	CC	CD	DA	DB	DC	DE	DF	Part no.
		H9						
32	48	10	15	142	14	10,5	14	KF-11032SI
40	54	12	18	160	16,5	12	16	KF-11040SI
50	65	12	20	170	17,5	12	16	KF-11050SI
63	75	16	21	190	21,5	15	21	KF-11063SI
80	95	16	27	210	24	15	21	KF-11080SI
100	115	20	29,5	230	28	18	25	KF-11100SI
125	140	30	40	275	30	25	37	KF-11125SI

Front/rear flange (ISO MF1-MF2)

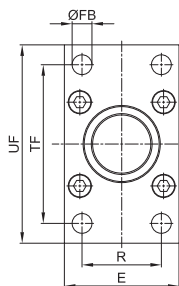
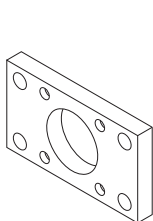

> Rear mounting

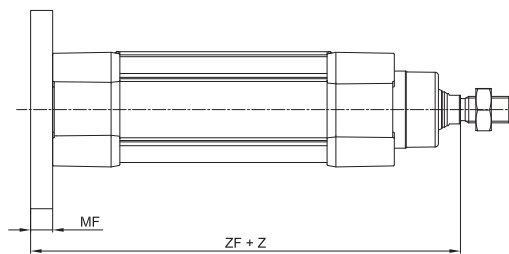

> Front mounting

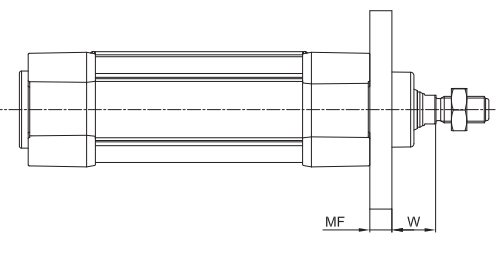

Material: Stainless steel AISI 304

Z = Stroke

Ø	E	FB	MF	R	TF	UF	W		ZF		Part no.
		H13	± 0,2	JS14	JS14	Max					
32	45	7	10	32	64	80	16	±1,6	130	±1,25	KF-12032I
40	52	9	10	36	72	90	20	±1,6	145	±1,25	KF-12040I
50	65	9	12	45	90	110	25	±2	155	±1,25	KF-12050I
63	75	9	12	50	100	120	25	±2	170	±1,6	KF-12063I
80	95	12	16	63	126	150	30	±2	190	±1,6	KF-12080I
100	115	14	16	75	150	170	35	±2	205	±1,6	KF-12100I
125	140	16	20	90	180	205	45	±2,5	245	±2	KF-12125I

Angle bracket (ISO MS1)

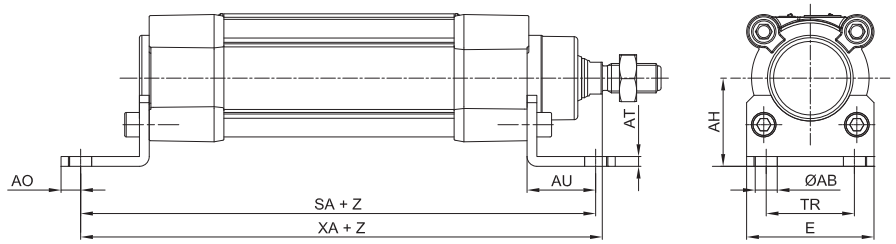
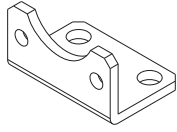

Material: Stainless steel AISI 304

Z = Stroke

Ø	ØAB	AH	AO	AT	AU	E	SA	TR	XA	Part no.		
	H13	JS15									±0,2	JS14
32	7	32	6	4	24	45	142	±1,25	32	144	±1,25	KF-13032I
40	9	36	8	4	28	52	161	±1,25	36	163	±1,25	KF-13040I
50	9	45	10	5	32	64	170	±1,25	45	175	±1,25	KF-13050I
63	9	50	12	5	32	74	185	±1,6	50	190	±1,6	KF-13063I
80	12	63	15	6	41	94	210	±1,6	63	215	±1,6	KF-13080I
100	14	71	20	6	41	114	220	±1,6	75	230	±1,6	KF-13100I
125	16	90	15	8	45	140	250	±2	90	270	±2	KF-13125I

Intermediate hinge for tie-rods

1

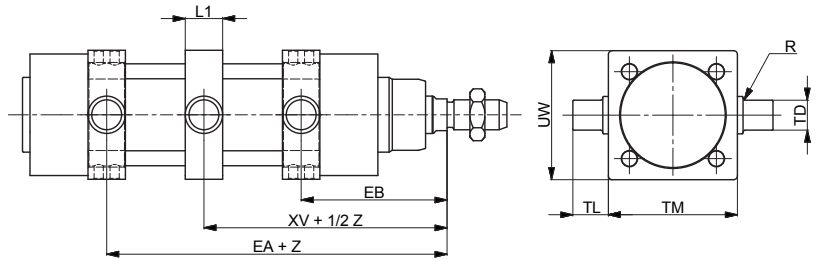
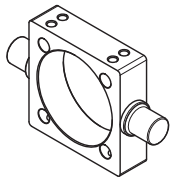

Material: Stainless steel AISI 304

Ø	EA	EB	L1	R	TD	TL	TM	UW	XV	Part no.	
	Max	min									e9
32	82	64	22	0,5	12	12	50	65	73	±2	KF-14032TI
40	93	72	22	0,5	16	16	63	75	82,5	±2	KF-14040TI
50	101	79	22	0,5	16	16	75	95	90	±2	KF-14050TI
63	107	88	27,5	1	20	20	90	105	97,5	±2	KF-14063TI
80	123	97	27,5	1,5	20	20	110	130	110	±2	KF-14080TI
100	131	109	33	1	25	25	132	145	120	±2	KF-14100TI
125	164	126	33	1	25	25	160	175	145	±2,5	KF-14125TI

Counter hinge 90° (CETOP RP107P)

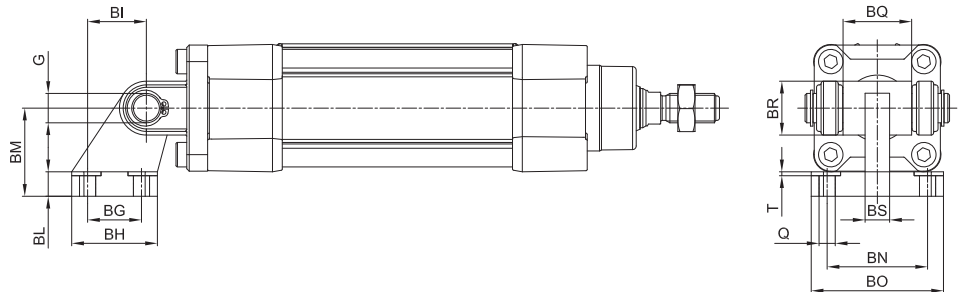
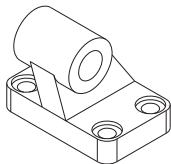

Material: Stainless steel AISI 304

Ø	Q	BG	BH	BI	BL	BM	BN	BO	BS	BR	T	G	Part no.
	H13	JS14	Max	JS14		JS15	JS14	Max	Max	Max	Max	H9	
32	6,6	18	31	21	8	32	38	51	10	20	1,6	10	KF-19032CTAI
40	6,6	22	35	24	10	36	41	54	15	22	1,6	12	KF-19040CTAI
50	9	30	45	33	12	45	50	65	16	26	1,6	12	KF-19050CTAI
63	9	35	50	37	14	50	52	67	16	30	1,6	16	KF-19063CTAI
80	11	40	60	47	14	63	66	86	20	30	2,5	16	KF-19080CTAI
100	11	50	70	55	17	71	76	96	20	38	2,5	20	KF-19100CTAI
125	14	60	90	70	20	90	94	124	30	45	3,2	25	KF-19125CTAI

Hinge support

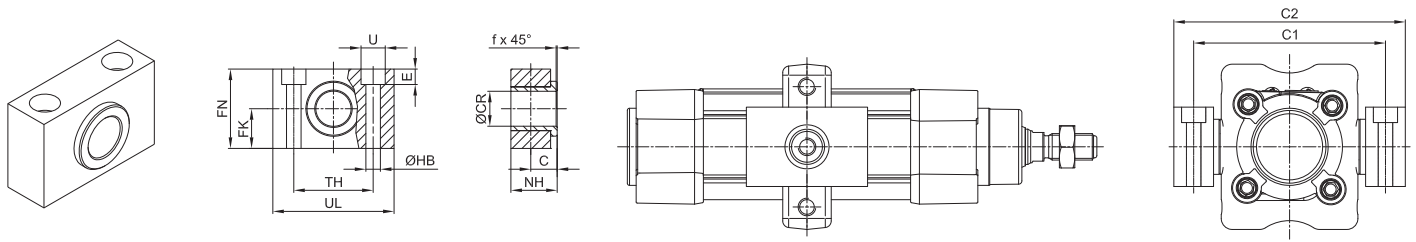

Material: Stainless steel AISI 316

Ø	C	ØCR	FK	FN	ØHB	NH	TH	UL	ØU	E	f	C1	C2	Part no.
	H9	f7	±0,1				±0,1			±0,5				
32	10,5	12	15	30	6,6	18	32	46	11	7	1	71	86	KF-41032I
40	12	16	18	36	9	21	36	55	15	9	1,6	87	105	KF-41040050I
50	12	16	18	36	9	21	36	55	15	9	1,6	99	117	KF-41040050I
63	13	20	20	40	11	23	42	65	18	11	1,6	116	136	KF-41063080I
80	13	20	20	40	11	23	42	65	18	11	1,6	136	156	KF-41063080I
100	16	25	25	50	14	28,5	50	75	20	13	2	164	189	KF-41100125I
125	16	25	25	50	14	28,5	50	75	20	13	2	192	217	KF-41100125I

Female fork with pin

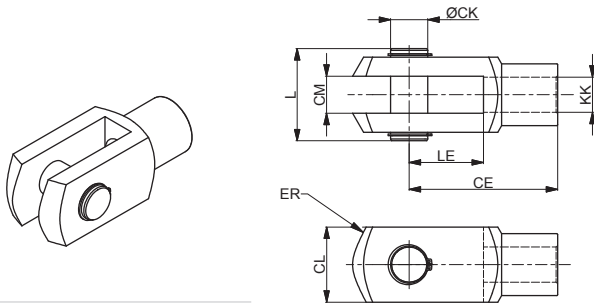

Material: Stainless steel AISI 304

Ø	CE	CK	CL	CM	ER	KK	L	LE	Part no.
	B12								
32	40	10	20	10	16	M10x1,25	26	20	KF-15032PI
40	48	12	24	12	19	M12x1,25	32	24	KF-15040PI
50 - 63	64	16	32	16	25	M16x1,5	40	32	KF-15050PI
80 - 100	80	20	40	20	32	M20x1,5	50	40	KF-15080PI
125	110	30	55	30	45	M27x2	65	54	KF-15125PI

Fork with clip suitable for piston rod according to ISO 8140

Articulated self-lubricating fork

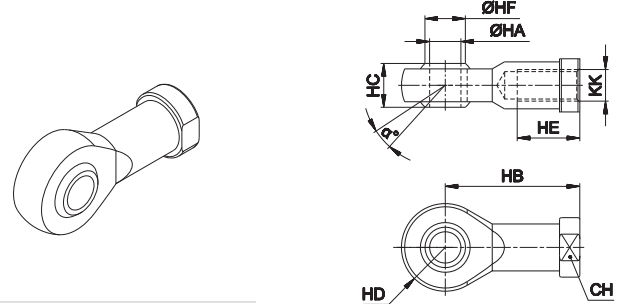

Material: Stainless steel AISI 304

Ø	α°	CH	KK	HA	HB	HC	HD	HE	HF	Part no.
		H7					0 -0,12			
32	13	17	M10x1,25	10	43	14	14	20	12,9	KF-17032I
40	13	19	M12x1,25	12	50	16	16	22	15,4	KF-17040I
50 - 63	15	22	M16x1,5	16	64	21	21	28	19,3	KF-17050I
80 - 100	14	30	M20 x 1,5	20	77	25	25	33	24,3	KF-17080I
125	17	41	M27x2	30	110	37	35	51	34,8	KF-17125I

1  
CYLINDERS

Piston rod nut



Material: Stainless steel AISI 304

Ø	KK	KV	KW	Part no.
32	M10x1,25	17	6	KF-16032I
40	M12x1,25	19	7	KF-16040I
50 - 63	M16x1,5	24	8	KF-16050I
80 - 100	M20x1,5	30	9	KF-16080I
125	M27x2	41	12	KF-16125I

DF bracket

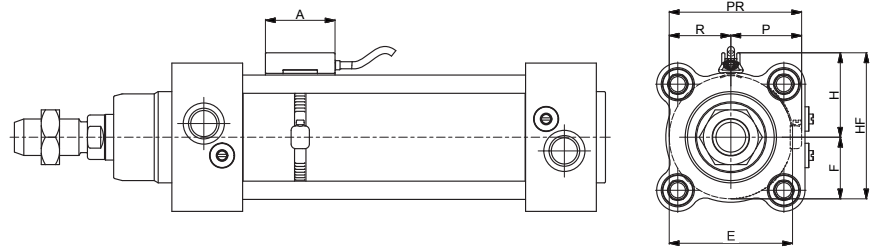
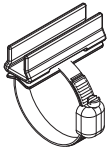

Material: Stainless steel AISI 303

Ø	A	E	H	F	HF	P	R	PR	Part no.
32	34	33,5	45	16,75	78,5	39	33,5	72,5	DH-P025032DFI
40	34	41,5	53	20,75	94,5	47	41,5	88,5	DH-P040DFI
50	34	51,5	63	25,75	114,5	57	51,5	108,5	DH-P050DFI
63	34	64,5	76	32,25	140,5	70	64,5	134,5	DH-P063DFI
80	34	81,5	93	40,75	174,5	87	81,5	168,5	DH-P080DFI
100	34	101,5	113	50,75	214,5	107	101,5	208,5	DH-P100DFI
125	34	126,5	138	63,25	264,5	132	126,5	258,5	DH-P125DFI

For DF sensors see accessories section

DF sensor

1

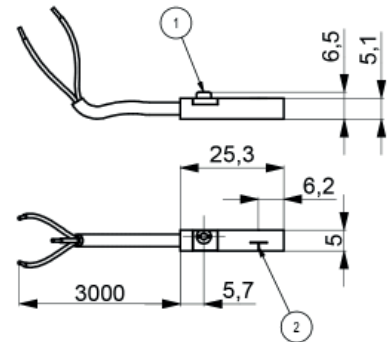
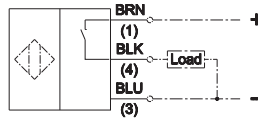
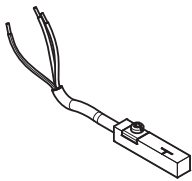

1	2	Part no.
fixing eccentric	active sensing face	DF-P700L06

# PRM

## ISO 21287 Stainless steel compact pneumatic cylinders Ø 20 ÷ 100 mm

- Stainless steel AISI 316
- Double acting and single acting versions
- Through piston rod versions
- FDA approved piston seals

Available ATEX version upon request

CE II 2GDc T4



### TECHNICAL CHARACTERISTICS

Ambient temperature	0 ÷ 80 °C (-20°C with dry air)
Fluid	compressed air, filtered air, not lubricated
Working pressure	1 ÷ 10 bar (double acting) 2 ÷ 10 bar (simple acting)
Bores	Ø 20 - 25 - 32 - 40 - 50 - 63 - 80 - 100 mm

### CONSTRUCTIVE CHARACTERISTICS

End-caps	stainless steel AISI 316
Barrel	Ø20-25 stainless steel AISI 304, Ø32-100 stainless steel AISI 316
Piston	aluminium
Guide slide	PBT+PTFE
Piston rod	stainless steel AISI 316
Piston seal	polyurethane
Guide bush for piston rod	technopolymer
Magnet	Ø20÷50 neodimio, Ø63÷100 plastoferrite
O-Ring	nitrile rubber (NBR)
Tie-rods	stainless steel AISI 316

### CODIFICATION KEY

P	R	M	3	0	0	0	3	2	0	0	2	5	M	
1	2	3	4	5			6	7						

1 Series	2 Type	3 Version	4 Bore (mm)
PRM = Ø 20 ÷ 100 mm - ISO 21287 Stainless steel compact pneumatic cylinders	1 = Female piston rod 3 = Male piston rod	00 = D.A. Standard 01 = D.A. Through piston rod 60 = S.A. Retracted piston rod 70 = S.A. Extended piston rod  D.A. = Double acting S.A. = Single acting	020 = Ø20 050 = Ø50 025 = Ø25 063 = Ø63 032 = Ø32 080 = Ø80 040 = Ø40 100 = Ø100
5 Stroke (mm)	6 Magnetic	7 ATEX option	
0010 = 10 0100 = 100 0250 = 250 0025 = 25 0125 = 125 0300 = 300 0050 = 50 0160 = 160 0350 = 350 0075 = 75 0200 = 200 0400 = 400	M = Magnetic version (standard supplied)	X = Atex (upon request)  See ATEX Catalogue for types and versions	

Version with high temperature seals (Max 150°C) available upon request.

Fixing elements and accessories

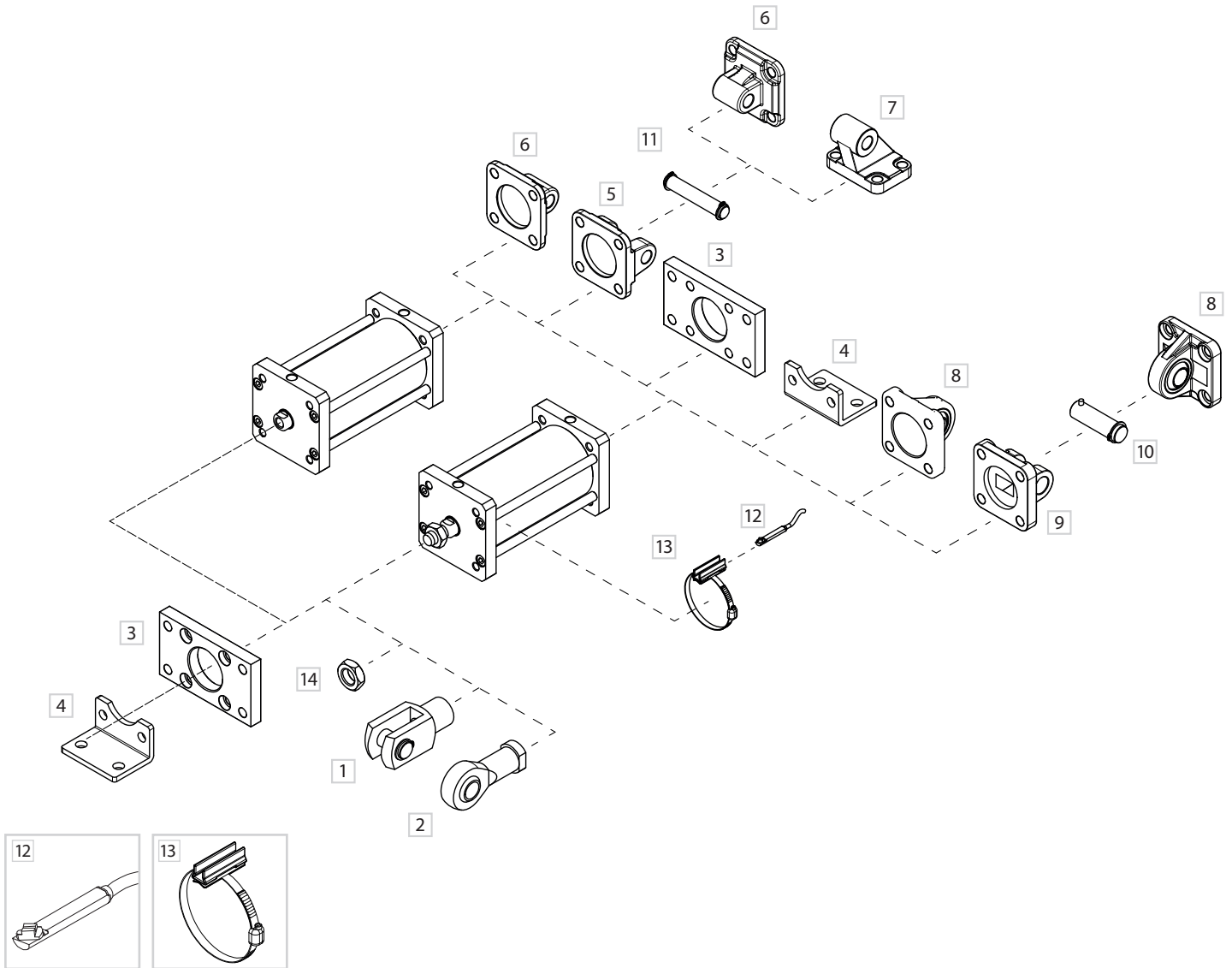

DESCRIPTION	NOTE	PART NO.
1 Female fork with pin	Stainless steel	KF-15 __ _PI
2 Articulated self-lubricating fork	Stainless steel	KF-17 __ _I
3 Front/rear flange (ISO MF1-MF2)	Stainless steel	KF-12 __ _I
4 Angle bracket (ISO MS1)	Stainless steel	KF-13 __ _I
5 Female hinge (ISO MP2)	Stainless steel	KF-10 __ _AI
6 Rear male hinge (ISO MP4)	Stainless steel	KF-11 __ _I
7 Counter hinge 90° (CETOP RP107P)	Stainless steel	KF-19 __ _CTAI
8 Articulated rear male hinge (ISO MP6)	Stainless steel	KF-11 __ _SI
9 Narrow female hinge with pin (DIN648K)	Stainless steel	KF-10 __ _ASI/
10 Narrow hinge pin (DIN648K)	Stainless steel	KF-18S I
11 Female hinge pin (ISO MS1)	Stainless steel	KF-18 _I
12 DF sensor	-	DF-P700L06
13 DF bracket and adapter	Stainless steel	DH-P __ _DFI
14 Piston rod nut	Stainless steel	KF-16 __ _I

### Double acting

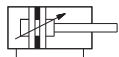

PRM100/PRM300  
D.A. Standard

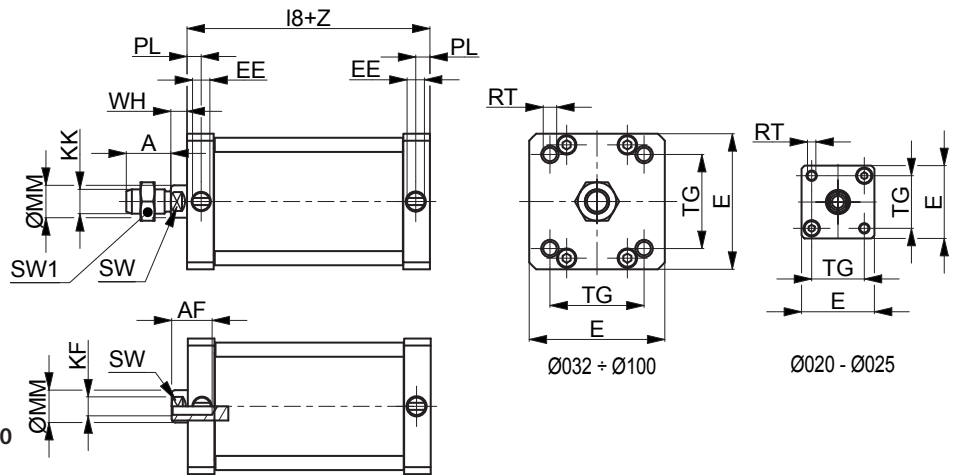

### Double acting through piston rod

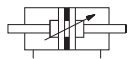

PRM101/PRP301  
D.A. Through piston rod

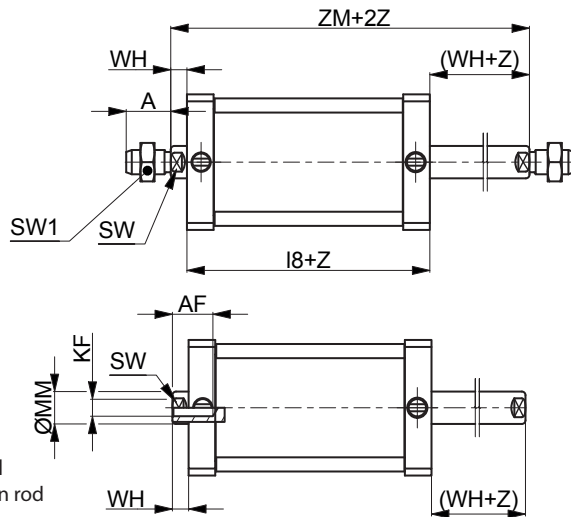

Z= Stroke

Ø	A	AF	KF	E+0,5	KK	I8	PL	RT	SW	TG	WH	ØMM	EE	SW1	ZM		
20	16	10	M6	32	M8	37	±0,3	6	M5	8	22	±0,3	6,5	10	M5x0,8	13	43,5
25	16	10	M6	36	M8	39	±0,3	6	M5	8	26	±0,3	6	10	M5x0,8	13	45
32	19	12	M8	50	M10x1,25	44	±0,4	7	M6	10	32,5	±0,5	6,5	12	G1/8	17	50,5
40	19	12	M8	57	M10x1,25	45	±0,7	7	M6	10	38	±0,6	7	12	G1/8	17	52
50	22	16	M10	67	M12x1,25	45	±0,7	7	M8	13	46,5	±0,7	8	16	G1/8	19	53
63	22	16	M10	80	M12x1,25	49	±0,8	7	M8	13	56,5	±0,7	8	16	G1/8	19	57
80	28	20	M12	96	M16x1,5	54	±0,8	7,5	M10	17	72	±0,7	10	20	G1/8	24	64
100	28	20	M12	116	M16x1,5	67	±1	7,5	M10	22	89	±1,1	10	25	G1/8	24	77

### Single acting retracted piston rod

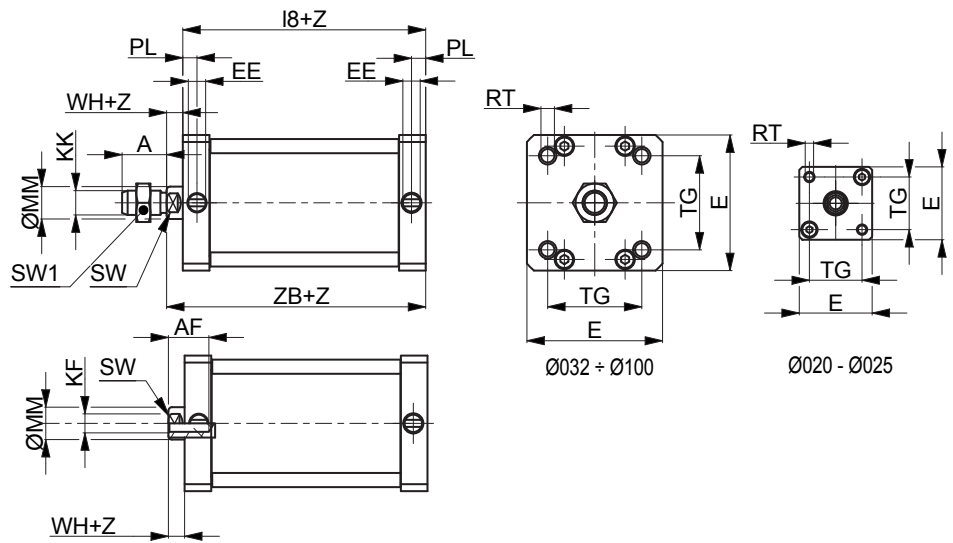

**PRM160/PRM360**  
S.A. Retracted piston rod

Z= Stroke

Ø	A	AF	KF	E+0,5	KK	I8	PL	RT	SW	TG	WH	ØMM	EE	SW1	ZB
20	16	10	M6	32	M8	47 ±0,3	6	M5	8	22 ±0,3	6,5	10	M5x0,8	13	53,5
25	16	10	M6	36	M8	49 ±0,3	6	M5	8	26 ±0,3	6	10	M5x0,8	13	55
32	19	12	M8	50	M10x1,25	44 ±0,4	7	M6	10	32,5 ±0,5	6,5	12	G1/8	17	50,5
40	19	12	M8	57	M10x1,25	45 ±0,7	7	M6	10	38 ±0,6	7	12	G1/8	17	52
50	22	16	M10	67	M12x1,25	45 ±0,7	7	M8	13	46,5 ±0,7	8	16	G1/8	19	53
63	22	16	M10	80	M12x1,25	49 ±0,8	7	M8	13	56,5 ±0,7	8	16	G1/8	19	57
80	28	20	M12	96	M16x1,5	54 ±0,8	7,5	M10	17	72 ±0,7	10	20	G1/8	24	64
100	28	20	M12	116	M16x1,5	67 ±1	7,5	M10	22	89 ±1,1	10	25	G1/8	24	77

1

### Single acting extended piston rod

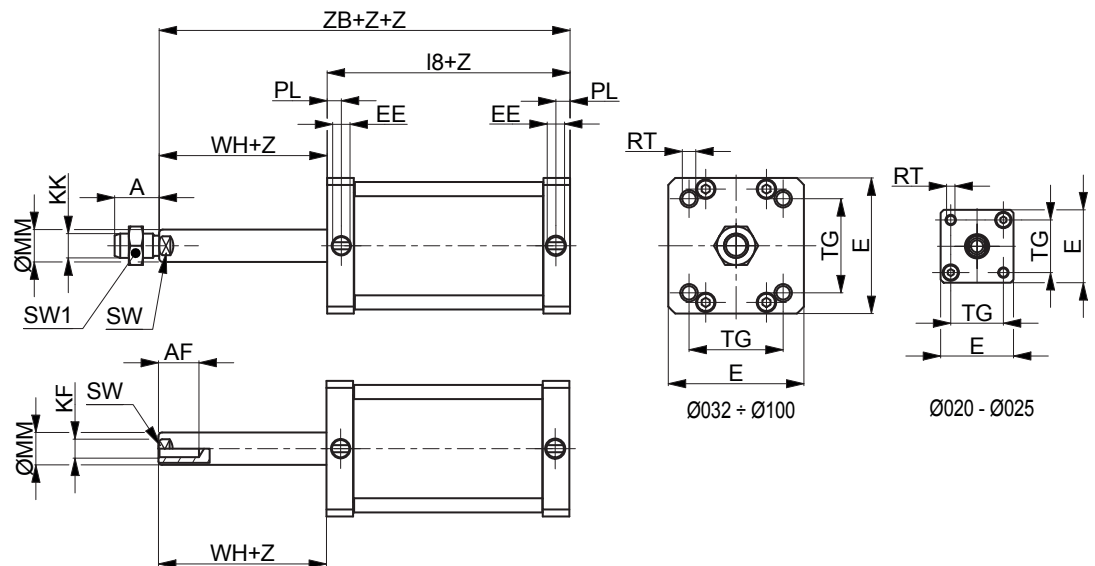

**PRM170/PRM370**  
S.A. Extended piston rod

Z= Stroke

Ø	A	AF	KF	E+0,5	KK	I8	PL	RT	SW	TG	WH	ØMM	EE	SW1	ZB
20	16	10	M6	32	M8	47 ±0,3	6	M5	8	22 ±0,3	6,5	10	M5x0,8	13	53,5
25	16	10	M6	36	M8	49 ±0,3	6	M5	8	26 ±0,3	6	10	M5x0,8	13	55
32	19	12	M8	50	M10x1,25	44 ±0,4	7	M6	10	32,5 ±0,5	6,5	12	G1/8	17	50,5
40	19	12	M8	57	M10x1,25	45 ±0,7	7	M6	10	38 ±0,6	7	12	G1/8	17	52
50	22	16	M10	67	M12x1,25	45 ±0,7	7	M8	13	46,5 ±0,7	8	16	G1/8	19	53
63	22	16	M10	80	M12x1,25	49 ±0,8	7	M8	13	56,5 ±0,7	8	16	G1/8	19	57
80	28	20	M12	96	M16x1,5	54 ±0,8	7,5	M10	17	72 ±0,7	10	20	G1/8	24	64
100	28	20	M12	116	M16x1,5	67 ±1	7,5	M10	22	89 ±1,1	10	25	G1/8	24	77



**Female hinge (ISO MP2) with pin**

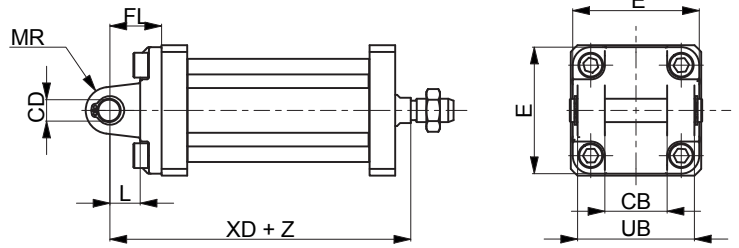
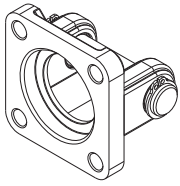

Material: Stainless steel AISI 304

Z = Stroke

Ø	CB	CD	E	FL	L	MR	UB	XD		Part no.
	H14	H9		± 0,2	min	Max	h14			
20	-	-	-	-	-	-	-	-	-	-
25	-	-	-	-	-	-	-	-	-	-
32	26	10	48	22	12	11	45	62,5	±1,25	KF-10032AI
40	28	12	54	25	15	13	52	67	±1,25	KF-10040AI
50	32	12	65	27	15	13	60	68	±1,25	KF-10050AI
63	40	16	75	32	20	17	70	77	±1,6	KF-10063AI
80	50	16	95	36	20	17	90	84	±1,6	KF-10080AI
100	60	20	115	41	25	21	110	102	±1,6	KF-10100AI

**Narrow female hinge with pin (DIN648K)**

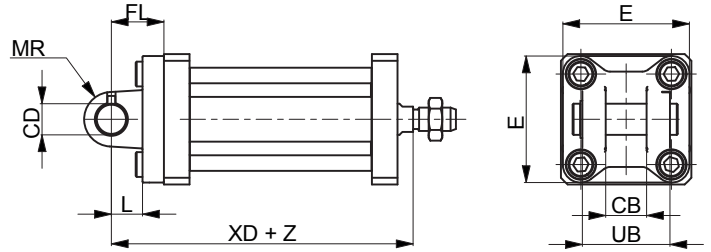
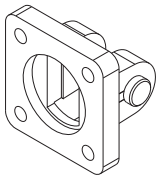

Material: Stainless steel AISI 316

Z = Stroke

Ø	CB	CD	E	FL	L	MR	UB	XD		Part no.
	H14	H9		± 0,2	min	Max	h14			
20	-	-	-	-	-	-	-	-	-	-
25	-	-	-	-	-	-	-	-	-	-
32	14	10	45	22	10	10	34	60,5	±1,25	KF-10032ASI
40	16	12	52	25	16	12	40	68	±1,25	KF-10040ASI
50	21	16	65	27	16	14	45	69	±1,5	KF-10050ASI
63	21	16	75	32	21	18	51	78	±1,6	KF-10063ASI
80	25	20	95	36	22	20	65	86	±1,6	KF-10080ASI
100	25	20	115	41	27	22	75	104	±1,6	KF-10100ASI

**Female hinge pin**

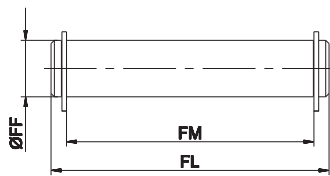

Including 2 circlips

Material: Stainless steel AISI 304

Ø	FF	FL	FM	Part no.
	f8			
20	-	-	-	-
25	-	-	-	-
32	10	53	46	KF-18032I
40	12	61,3	53	KF-18040I
50	12	69	61	KF-18050I
63	16	80,5	71	KF-18063I
80	16	100,5	91	KF-18080I
100	20	122,5	111	KF-18100I

**Narrow female hinge pin**

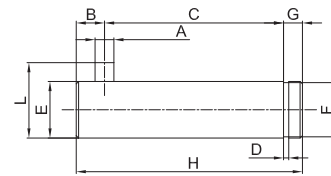

Including 2 circlips

Material: Stainless steel AISI 316

Ø	A	C	D	E	F	G	H	L	B	Part no.
	H12	$\begin{smallmatrix} +0,5 \\ -0,3 \end{smallmatrix}$	h13	f7	h11			$\begin{smallmatrix} 0 \\ -0,5 \end{smallmatrix}$		
20	-	-	-	-	-	-	-	-	-	-
25	-	-	-	-	-	-	-	-	-	-
32	3	32,5	1,1	10	9,6	4	41	14	4,5	KF-18032SI
40	4	38	1,1	12	11,5	4	48	16	6	0 KF-18040SI
50	4	43	1,1	16	15,2	5	54	20	6	-1 KF-18050SI
63	4	49	1,1	16	15,2	5	60	20	6	KF-18063SI
80	4	63	1,3	20	19	6	75	24	6	KF-18080SI
100	4	73	1,3	20	19	6	85	24	6	KF-18100SI

Rear male hinge (ISO MP4)

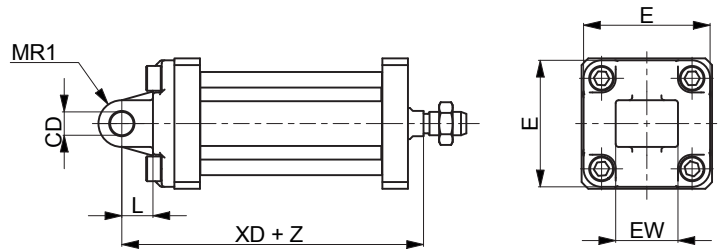
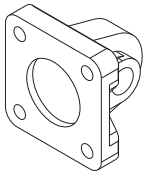

Material: Stainless steel AISI 304

Ø	CD	E	EW		L	MR1	XD		Part no.
	H9				min				
20	-	-	-	-	-	-	-	-	-
25	-	-	-	-	-	-	-	-	-
32	10	48	26	-0,2/-0,6	12	15*	62,5	±1,25	KF-11032I
40	12	54	28	-0,2/-0,6	15	18*	67	±1,25	KF-11040I
50	12	65	32	-0,2/-0,6	15	20*	68	±1,25	KF-11050I
63	16	75	40	-0,2/-0,6	20	23*	77	±1,6	KF-11063I
80	16	95	50	-0,2/-0,6	20	27*	84	±1,6	KF-11080I
100	20	115	60	-0,2/-0,6	25	29,5*	102	±1,6	KF-11100I

\* = Non-standard dimension

Articulated rear male hinge (ISO MP6)

1

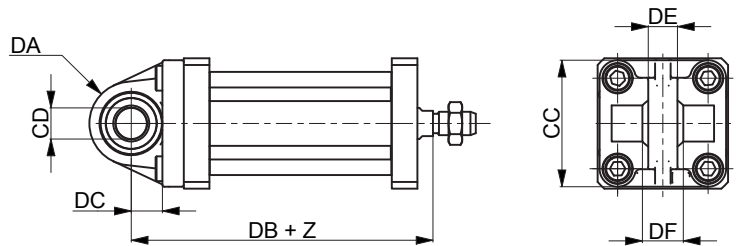
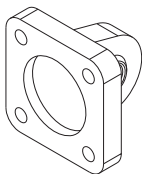

Material: Stainless steel AISI 316

Ø	CC	CD	DA	DB	DC	DE	DF	Part no.
		H9						
20	-	-	-	-	-	-	-	-
25	-	-	-	-	-	-	-	-
32	48	10	15	64	14	10,5	14	KF-11032SI
40	54	12	18	68,5	16,5	12	16	KF-11040SI
50	65	12	20	70,5	17,5	12	16	KF-11050SI
63	75	16	21	78,5	21,5	15	21	KF-11063SI
80	95	16	27	88	24	15	21	KF-11080SI
100	115	20	29,5	105	28	18	25	KF-11100SI

Front/rear flange (ISO MF1-MF2)

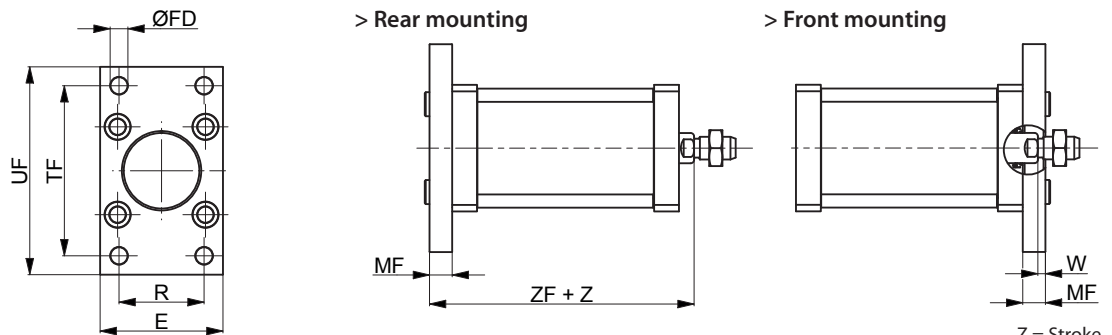
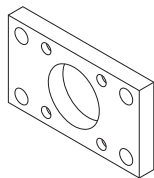

Material: Stainless steel AISI 304

Ø	E	FB	MF	R	TF	UF	W		ZF		Part no.
		H13	± 0,2	JS14	JS14	Max					
20	-	-	-	-	-	-	-	-	-	-	-
25	-	-	-	-	-	-	-	-	-	-	-
32	45	7	10	32	64	80	3,5	±1,6	54	±1,25	KF-12032I
40	52	9	10	36	72	90	3	±1,6	55	±1,25	KF-12040I
50	65	9	12	45	90	110	4	±2	57	±1,25	KF-12050I
63	75	9	12	50	100	120	4	±2	61	±1,6	KF-12063I
80	95	12	16	63	126	150	6	±2	70	±1,6	KF-12080I
100	115	14	16	75	150	170	6	±2	83	±1,6	KF-12100I

Angle bracket (ISO MS1)

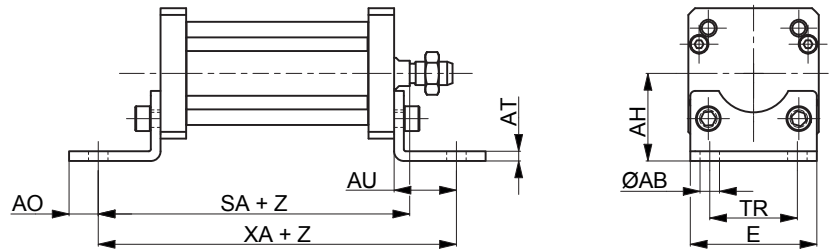
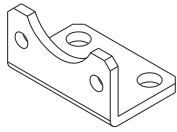

Material: Stainless steel AISI 304

Z = Stroke

Ø	ØAB	AH	AO	AT	AU	E	SA+		TR	XA+		Part no.
	H13	JS15					±0,2	JS14	±1,25	±1,25		
20	-	-	-	-	-	-	-	-	-	-	-	-
25	-	-	-	-	-	-	-	-	-	-	-	-
32	7	32	6	4	24	45	74,5	±1,25	32	98,5	±1,25	KF-13032I
40	9	36	8	4	28	52	80	±1,25	36	108	±1,25	KF-13040I
50	9	45	10	5	32	64	85	±1,25	45	117	±1,25	KF-13050I
63	9	50	12	5	32	74	89	±1,6	50	121	±1,6	KF-13063I
80	12	63	15	6	41	94	105	±1,6	63	146	±1,6	KF-13080I
100	14	71	20	6	41	114	118	±1,6	75	159	±1,6	KF-13100I

Counter hinge 90° (CETOP RP107P)

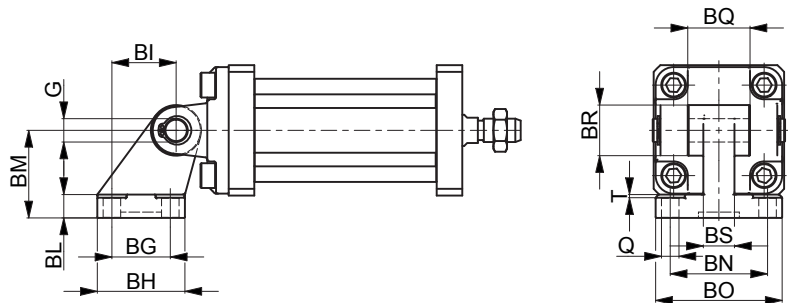
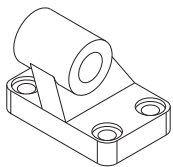

Material: Stainless steel AISI 304

Ø	Q	BG	BH	BI	BL	BM	BN	BO	BS	BR	T	G	Part no.
	H13	JS14	Max	JS14		JS15	JS14	Max	Max	Max	Max	H9	
20	-	-	-	-	-	-	-	-	-	-	-	-	-
25	-	-	-	-	-	-	-	-	-	-	-	-	-
32	6,6	18	31	21	8	32	38	51	10	20	1,6	10	KF-19032CTAI
40	6,6	22	35	24	10	36	41	54	15	22	1,6	12	KF-19040CTAI
50	9	30	45	33	12	45	50	65	16	26	1,6	12	KF-19050CTAI
63	9	35	50	37	14	50	52	67	16	30	1,6	16	KF-19063CTAI
80	11	40	60	47	14	63	66	86	20	30	2,5	16	KF-19080CTAI
100	11	50	70	55	17	71	76	96	20	38	2,5	20	KF-19100CTAI

1  
CYLINDERS

Female fork with pin

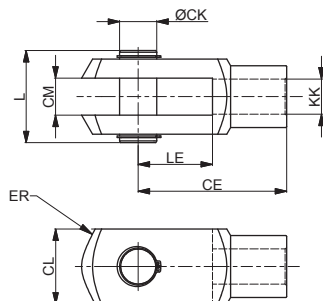
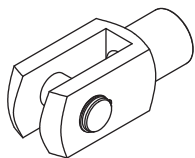

Material: Stainless steel AISI 304

Ø	CE	CK	CL	CM	ER	KK	L	LE	Part no.
				B12					
20 - 25	32	8	16	8	10	M8x1,25	22	16	MF-15020PI
32 - 40	40	10	20	10	16	M10x1,25	26	20	KF-15032PI
50 - 63	48	12	24	12	19	M12x1,25	32	24	KF-15040PI
80 - 100	64	16	32	16	25	M16x1,5	40	32	KF-15050PI

Articulated self-lubricating fork

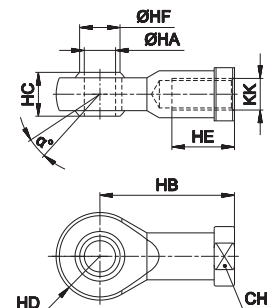
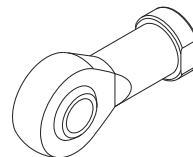

Material: Stainless steel AISI 304

Ø	α°	CH	KK	HA	HB	HC	HD	HE	HF	Part no.
20 - 25	14	14	M8x1,25	8	36	12	12	16	10,4	MF-17020I
32 - 40	13	17	M10x1,25	10	43	14	14	20	12,9	KF-17032I
50 - 63	13	19	M12x1,25	12	50	16	16	22	15,4	KF-17040I
80 - 100	15	22	M16x1,5	16	64	21	21	28	19,3	KF-17050I

Fork with clip suitable for piston rod according to ISO 8140

**Piston rod nut**

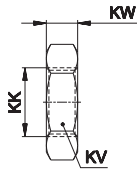

Material: Stainless steel AISI 304

Ø	KK	KV	KW	Part no.
20 - 25	M8x1,25	13	5	MF-16020I
32 - 40	M10x1,25	17	6	KF-16032I
50 - 63	M12x1,25	19	7	KF-16040I
80 - 100	M16x1,5	24	8	KF-16050I

**DF bracket**

1

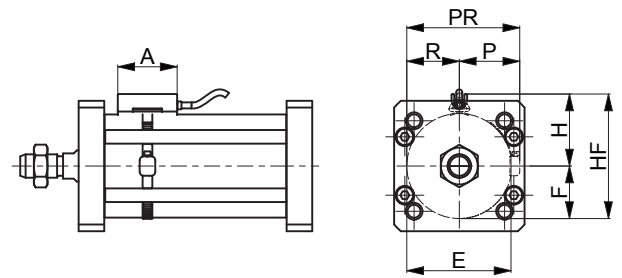
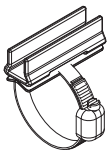

Material: Stainless steel AISI 303

Ø	A	E	H	F	HF	P	R	PR	Part no.
20	34	24	20	12	32	17	12	29	DH-P020DFI
25	34	32	23	16	39	19	16	35	DH-P025032DFI
32	34	41,5	53	16,75	94,5	47	41,5	88,5	DH-P025032DFI
40	34	51,5	63	20,75	114,5	57	51,5	108,5	DH-P040DFI
50	34	64,5	76	25,75	140,5	70	64,5	134,5	DH-P050DFI
63	34	81,5	93	32,25	174,5	87	81,5	168,5	DH-P063DFI
80	34	101,5	113	40,75	214,5	107	101,5	208,5	DH-P080DFI
100	34	126,5	138	50,75	264,5	132	126,5	258,5	DH-P100DFI

For DF sensors see accessories section

**DF sensor**

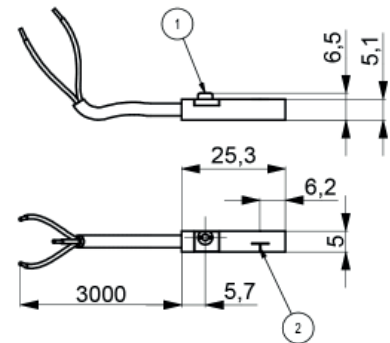
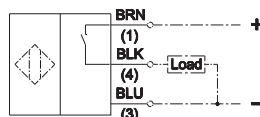
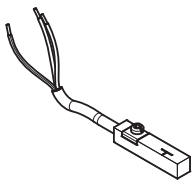

1	2	Part no.
fixing eccentric	active sensing face	DF-P700L06