

# FRL EVO

## COMPRESSED AIR TREATMENT COMPONENTS UNIT

### TECHNICAL CHARACTERISTICS

#### Series FRL Evo

The "FRL Evo" line is modular and the connection between the various modules is extremely simplified thanks to the quick coupling brackets.

Assembly of the modules may change according to individual use. For correct operation, Aignep recommends the shut off valve in the first position and the soft start valve last.

There is always an arrow on every module, to indicate the correct direction of flow.

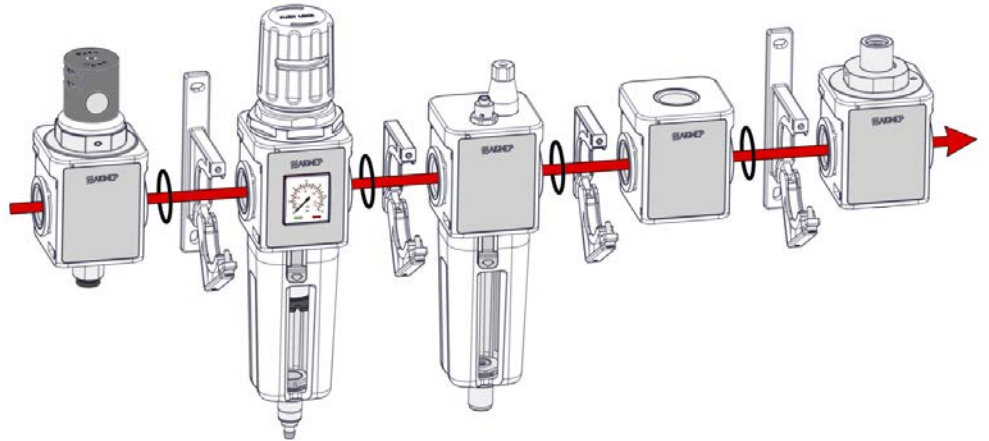

#### Brackets

Two brackets available for fixing to the wall. Furthermore, the flow adjusters can be mounted also as a panel mount.

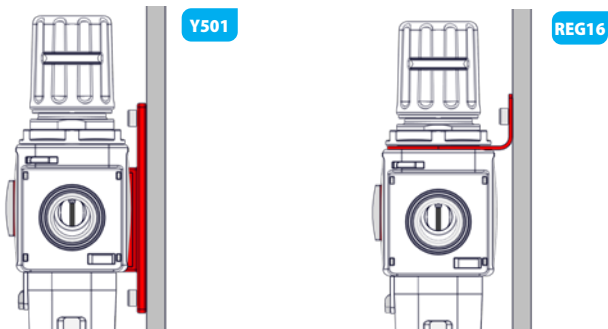

#### Release

Very quick bowls release: press the button and rotate the bowl as per drawing and release downwards. The transparent windows in the bowl simplify viewing the level of condensate in the filter or of the oil in the lubricator unit.

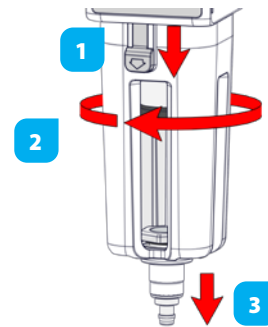

Shut off valves available in 3 versions: manual with possibility of locking and anti-tampering system, pneumatic and electro-pneumatic.

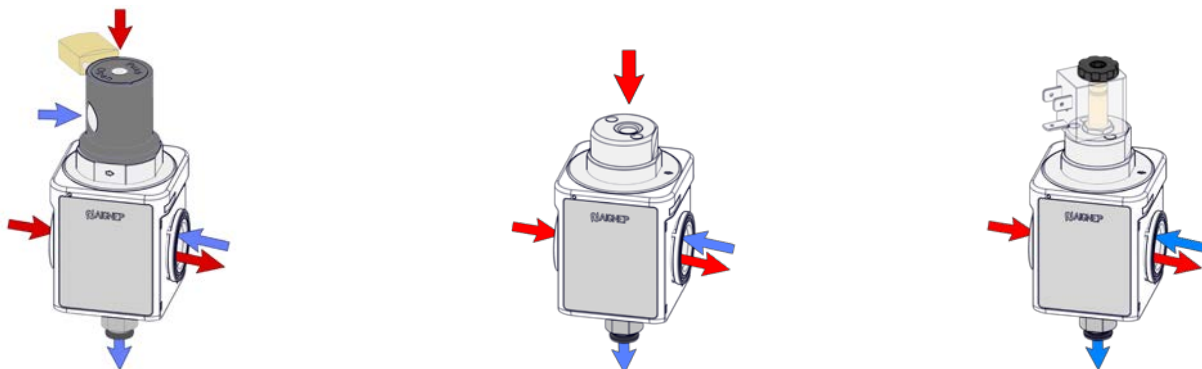

### Manual control position change

- 1 Unscrew the two screws
- 2 Detach the top part and rotate 180°
- 3 Ensure that the two seals remain in place
- 4 Screw the two screws



### Regulator

Pressure adjusters with manometer incorporated. Knob with locking and anti-tampering system. On request, assembly kit for 1/8 manometer.

### Regulator

Adjusters can be assembled in series with the individual outlet adjustment and manometer incorporated.

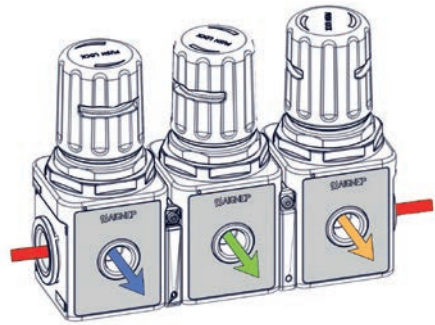
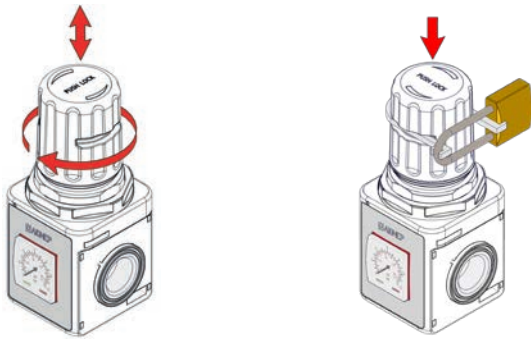

### Manual control position change

Multiple choice of manometers and pressure switches. If necessary, it is possible to invert the position of the manometer. (Y020 - Y030)

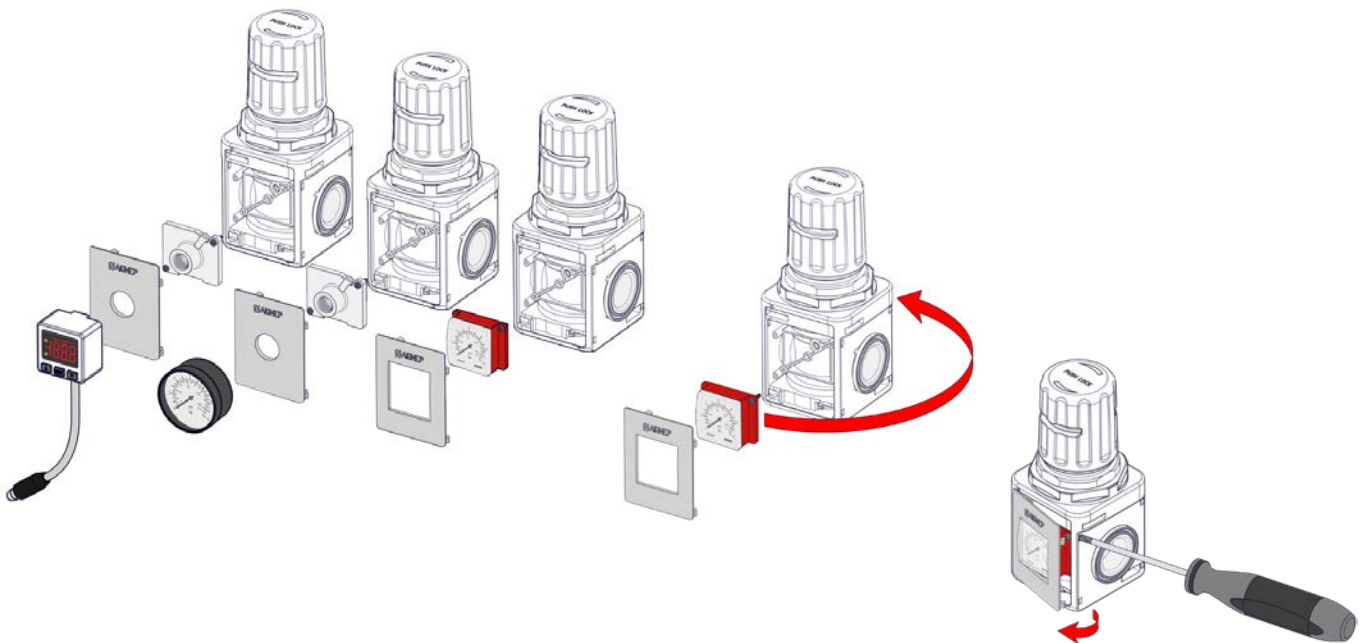

### Exhaust

The condensate drain is available with depressure drain or automatic with float.

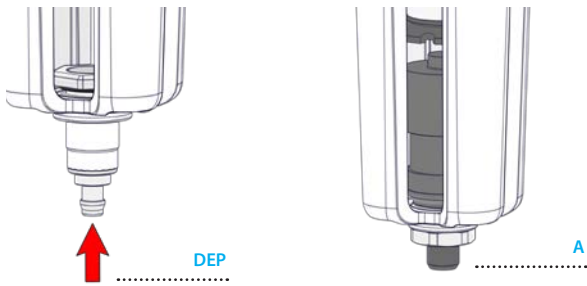

### Lubricator

Lubricator unit with manual loading or with automatic vacuum-operated loading

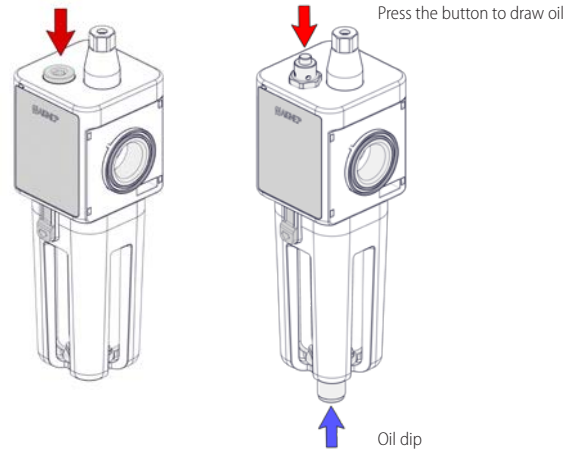

### Information

20 µm, 5 µm filters and 0.01 µm coalescence filter

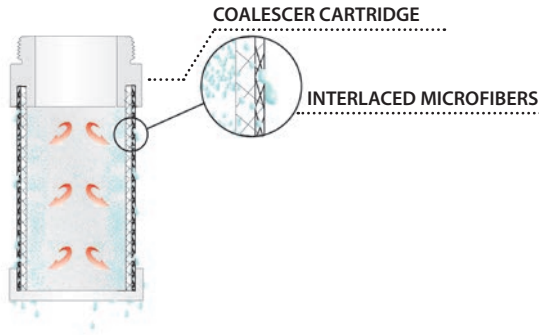

### Soft start

Soft start valve with adjustment screw.

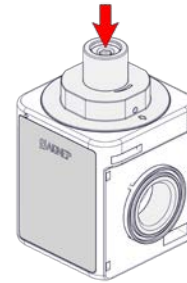

## TECHNICAL CHARACTERISTICS GENERAL

	FRL 1	FRL 2	FRL 3
<b>REFERENCE STANDARD</b>	1907/2006 REACH ✓	2011/65/CE RoHS ✓	2011/65/CE RoHS ✓
<b>REFERENCE STANDARD</b>		2011/65/CE RoHS ✓	II 2GD Ex h TX Ex
<b>FLUID</b>	Compressed Air		
<b>THREADED METALLICO</b>	1/4" 3/8"	3/8" 1/2"	3/4" 1"
<b>MAX PRESSURE</b>	15 bar	15 bar	13 bar
<b>TEMPERATURE</b>	-10 °C - +50 °C		

	FRL 1	FRL 2	FRL 3
<b>ASSEMBLY POSITION</b>	Vertical		
<b>REGULATION RANGE</b>	0 ÷ 2 bar (FRL 1 - 2)		0 ÷ 4 bar (FRL 1 - 2)
	0 ÷ 8 bar STANDARD (FRL 1 - 2 - 3)		
	0 ÷ 12 bar (FRL 1 - 2 - 3)		
<b>WALL CLAMPING SCREWS</b>	M5 x15	M5 x15	M6 x15
<b>FILTRATION GRADE</b>	5 µm 20 µm STANDARD 0.01 µm		
<b>TORQUE SPECIFICATIONS</b>	Max 15 Nm	Max 20 Nm	Max 50 Nm
<b>BOWL CAPACITY</b>	28 m³	37 m³	151 m³

### Information

Features may vary depending on the item.



Code standard	Size	Thread	Filtration	Flow Rate	Exhaust
Y010 103 201 000	FIL 1	1/4"	20 µm	2500 NI/min	DEP
Y010 104 201 000	FIL 1	3/8"	20 µm	2500 NI/min	DEP
Y010 104 202 000	FIL 1	3/8"	20 µm	2500 NI/min	A
Y010 204 201 000	FIL 2	3/8"	20 µm	4100 NI/min	DEP
Y010 205 201 000	FIL 2	1/2"	20 µm	4100 NI/min	DEP
Y010 205 202 000	FIL 2	1/2"	20 µm	4100 NI/min	A
Y010 307 201 000	FIL 3	3/4"	20 µm	7900 NI/min	DEP
Y010 309 201 000	FIL 3	1"	20 µm	7900 NI/min	DEP
Y010 309 202 000	FIL 3	1"	20 µm	7900 NI/min	A

**Exhaust**

**DEP =** The depressure drain condensate drain is normally in the open position, i.e. it automatically drains the condensate when there is no pressure in the bowl. By pressing the hose connector, it is also possible to drain the condensate when pressurised.

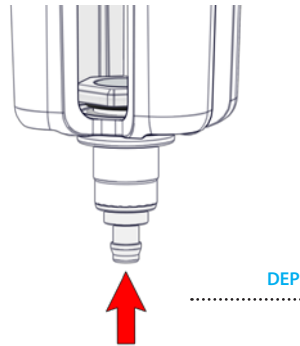

**Exhaust**

**A =** The automatic condensate drain with float, drains the condensate when the maximum level is reached, independently from the pressure used

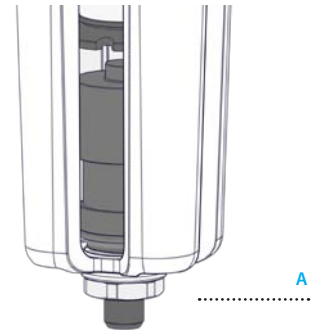

Code	Size	Thread	Filtration	Condensate exhaust	-
Y 0 1 0	1	0 3	1	0 1	0 0 0
FRL 1	→	03 = G 1/4" 04 = G 3/8"	1 = 5 µm 2 = 20 µm	1 = Depressure drain 2 = Automatic with float (max 8 bar)	
FRL 2	→	04 = G 3/8" 05 = G 1/2"			
FRL 3	→	07 = G 3/4" 09 = G 1"			

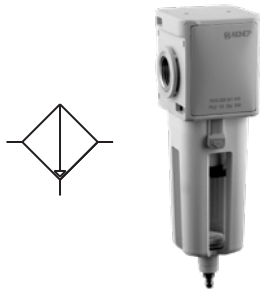

Code standard	Size	Thread	Filtration	Flow Rate	Exhaust
<a href="#">Y015 103 401 000</a>	FC 1	1/4"	0.01 µm	600 NI/min	DEP
<a href="#">Y015 104 401 000</a>	FC 1	3/8"	0.01 µm	600 NI/min	DEP
<a href="#">Y015 104 402 000</a>	FC 1	3/8"	0.01 µm	600 NI/min	A
<a href="#">Y015 204 401 000</a>	FC 2	3/8"	0.01 µm	750 NI/min	DEP
<a href="#">Y015 205 401 000</a>	FC 2	1/2"	0.01 µm	750 NI/min	DEP
<a href="#">Y015 205 402 000</a>	FC 2	1/2"	0.01 µm	750 NI/min	A
<a href="#">Y015 307 401 000</a>	FC 3	3/4"	0.01 µm	1400 NI/min	DEP
<a href="#">Y015 309 401 000</a>	FC 3	1"	0.01 µm	1400 NI/min	DEP
<a href="#">Y015 309 402 000</a>	FC 3	1"	0.01 µm	1400 NI/min	A

### Exhaust

**DEP =** The depressure drain condensate drain is normally in the open position, i.e. it automatically drains the condensate when there is no pressure in the bowl. By pressing the hose connector, it is also possible to drain the condensate when pressurised.

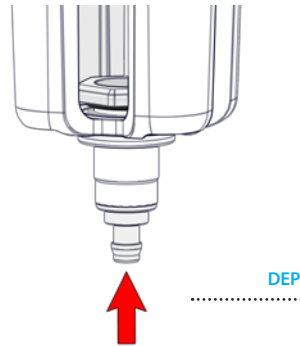

### Exhaust

**A =** The automatic condensate drain with float, drains the condensate when the maximum level is reached, independently from the pressure used

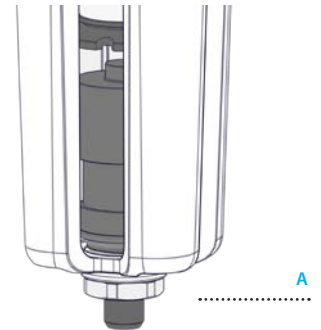

Code	Size	Thread	Filtration	Condensate exhaust
<b>Y 0 1 5</b>	<b>1</b>	<b>0 3</b>	<b>4</b>	<b>0 1 0 0 0</b>
FRL1	→	03 = G 1/4 04 = G 3/8	04 = 0,01 µm	1 = Depressure drain 2 = Automatic with float (max 8 bar)
FRL2	→	04 = G 3/8 05 = G 1/2		
FRL3	→	07 = G 3/4 09 = G 1		

### Informations

Coalescer cartridge is made of microfiber layer with external stainless steel structure. Coalescing cartridge uses inertial impact, interception and coalescence to gather liquid particles into drops.

These drops will fall into bowl bottom.

Coalescing Filter is used as Oil Separator which removes oil-vapours from air output. We recommend to install a 5 µm Filter upstream to protect coalescing filter from choking of cartridge.

### COALESCER CARTRIDGE

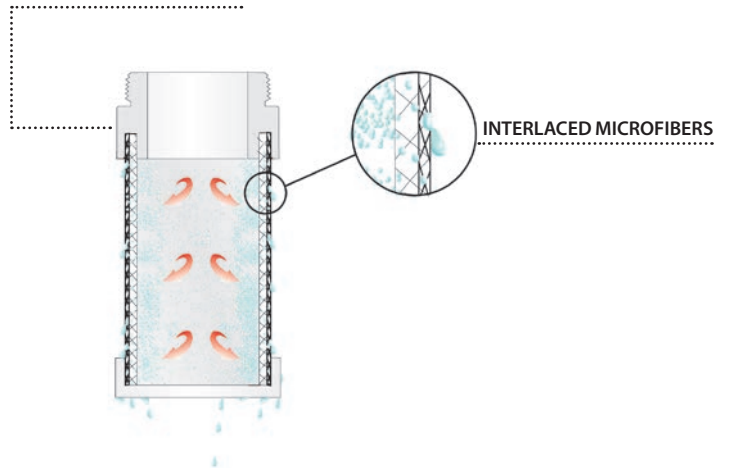

## SERIES FRL EVO - Y016 ACTIVE CARBON FILTER

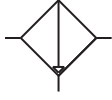

Code standard	Size	Thread	Filtration	Flow Rate	Exhaust
<a href="#">Y016 103 501 000</a>	AC 1	1/4"	< 0.005 mg/m <sup>3</sup>	1270 NI/min	DEP
<a href="#">Y016 104 501 000</a>	AC 1	3/8"	< 0.005 mg/m <sup>3</sup>	1270 NI/min	DEP
<a href="#">Y016 204 501 000</a>	AC 2	3/8"	< 0.005 mg/m <sup>3</sup>	1810 NI/min	DEP
<a href="#">Y016 205 501 000</a>	AC 2	1/2"	< 0.005 mg/m <sup>3</sup>	1810 NI/min	DEP
<a href="#">Y016 307 501 000</a>	AC 3	3/4"	< 0.005 mg/m <sup>3</sup>	3500 NI/min	DEP
<a href="#">Y016 309 501 000</a>	AC 3	1"	< 0.005 mg/m <sup>3</sup>	3500 NI/min	DEP



It's recommended to replace the activated carbon filter (Cod. T546) every 6 months.

### Exhaust

**DEP =** The depressure drain condensate drain is normally in the open position, i.e. it automatically drains the condensate when there is no pressure in the bowl. By pressing the hose connector, it is also possible to drain the condensate when pressurised.

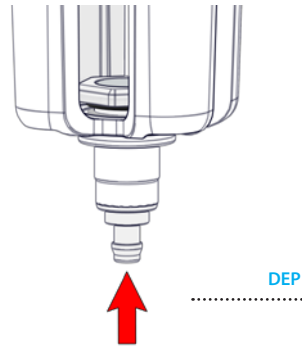

Code	Size	Thread	Filtration	Condensate exhaust	-
<b>Y 0 1 6</b>	<b>1</b>	<b>0 3</b>	<b>5</b>	<b>0 1</b>	<b>0 0 0</b>
FRL 1	→	03 = G 1/4" 04 = G 3/8"	05 = <0.005 mg/m <sup>3</sup>	1 = Depressure drain	
FRL 2	→	04 = G 3/8" 05 = G 1/2"			
FRL 3	→	07 = G 3/4" 09 = G 1"			



Code standard	Size	Thread	Regulation	Flow Rate
Y020 103 030 000	REG 1	1/4"	0 ÷ 8 bar	2600 NI/min
Y020 104 030 000	REG 1	3/8"	0 ÷ 8 bar	2600 NI/min
Y020 204 030 000	REG 2	3/8"	0 ÷ 8 bar	4000 NI/min
Y020 205 030 000	REG 2	1/2"	0 ÷ 8 bar	4000 NI/min
Y020 307 030 000	REG 3	3/4"	0 ÷ 8 bar	7700 NI/min
Y020 309 030 000	REG 3	1"	0 ÷ 8 bar	7700 NI/min

Code	Size	Thread	Regulation	Manometer System
Y 0 2 0	1	0 3	0 1 0	0 0 0
	FRL1 →	03 = G 1/4 04 = G 3/8	1 = 0÷2 bar (G1 -G2) 2 = 0÷4 bar (G1 - G2) 3 = 0÷8 bar (G1 - G2 - G3) 4 = 0÷12 bar (G1 - G2 - G3)	0 = Manometer incorporated 2 = Adapter for manometer 1/8 Gas (Manometer not included)
	FRL2 →	04 = G 3/8 05 = G 1/2		
	FRL3 →	07 = G 3/4 09 = G 1		

### Regulator

Follow the indications below to set the pressure:

- 1 Raise the knob to the regulating position;
- 2 Set the desired pressure always in ascending manner;
- 3 Press the knob into the block position.

The knob can be padlocked to prevent tampering.

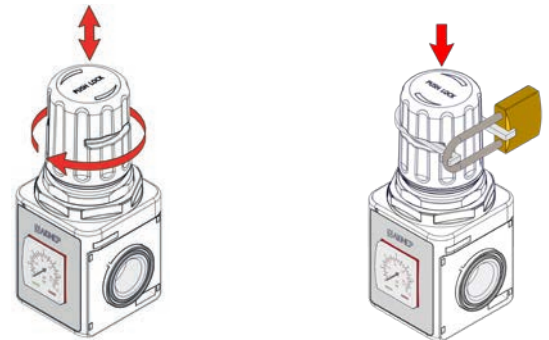

### Flow Characteristics

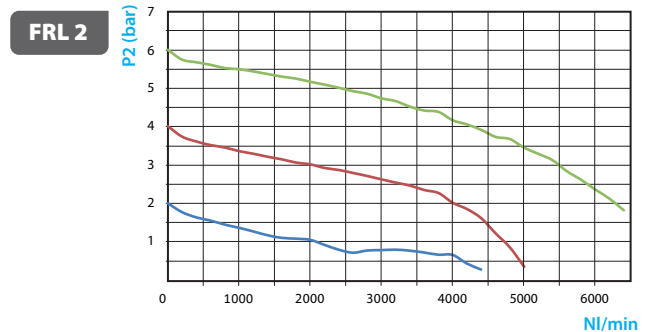
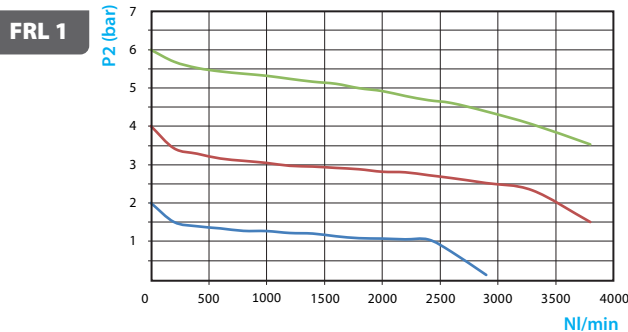

Inlet pressure	Outlet pressure	Air flow
7 bar	P2 (bar)	NI/min (20 °C - 1 bar)

## SERIES FRL EVO - Y025 FRONT REGULATOR

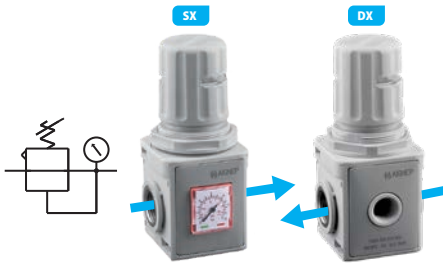

Code standard	Size	Thread	Regulation	Flow Rate
<b>SX Manometer incorporated - Front</b>				
Y025 103 030 000	REG F 1	1/4"	0 ÷ 8 bar	2700 NI/min
Y025 104 030 000	REG F 1	3/8"	0 ÷ 8 bar	2700 NI/min
<b>DX Manometer incorporated - Back</b>				
Y025 103 030 001	REG F 1	1/4"	0 ÷ 8 bar	2700 NI/min
Y025 104 030 001	REG F 1	3/8"	0 ÷ 8 bar	2700 NI/min
Y025 204 030 000	REG F 2	3/8"	0 ÷ 8 bar	3500 NI/min
Y025 205 030 000	REG F 2	1/2"	0 ÷ 8 bar	3500 NI/min
<b>DX Manometer incorporated - Back</b>				
Y025 103 030 001	REG F 1	1/4"	0 ÷ 8 bar	2700 NI/min
Y025 104 030 001	REG F 1	3/8"	0 ÷ 8 bar	2700 NI/min
Y025 204 030 001	REG F 2	3/8"	0 ÷ 8 bar	3500 NI/min
Y025 205 030 001	REG F 2	1/2"	0 ÷ 8 bar	3500 NI/min

Code	Size	Thread	Regulation	Manometer System
Y 0 2 5	1	0 3	0 1 0	0 0 0
	FRL1	03 = G 1/4 04 = G 3/8	1 = 0 ÷ 2 bar 2 = 0 ÷ 4 bar 3 = 0 ÷ 8 bar 4 = 0 ÷ 12 bar	0 = SX Manometer incorporated - Front 1 = DX Manometer incorporated - Back 2 = SX Adapter for manometer 1/8 Gas - Front 3 = DX Adapter for manometer 1/8 Gas - Back
	FRL2	04 = G 3/8 05 = G 1/2		

### Regulator

The front adjusters can be positioned in series.  
Each individual adjuster will have one adjustment and an independent outlet (1,2,3).

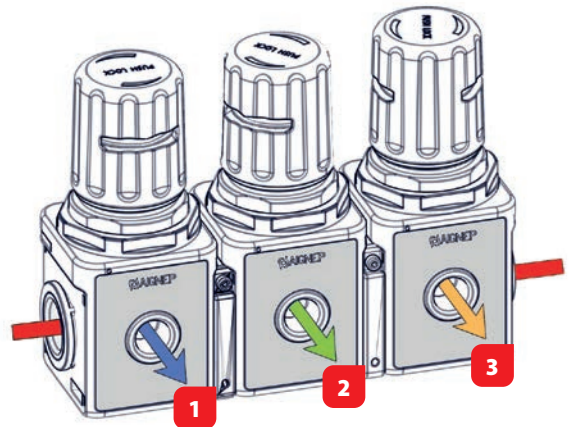

### Regulator

Follow the indications below to set the pressure:

- 1 Raise the knob to the regulating position;
- 2 Set the desired pressure always in ascending manner;
- 3 Press the knob into the block position.

The knob can be padlocked to prevent tampering.

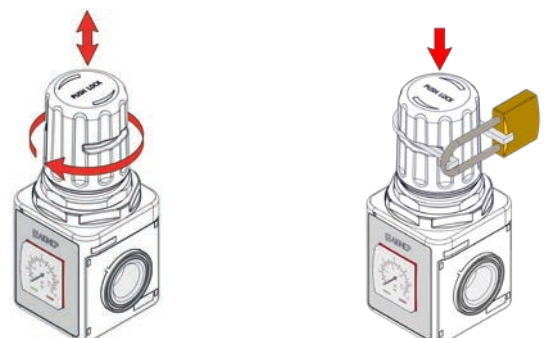

## SERIES FRL EVO - Y030 FILTER REGULATOR

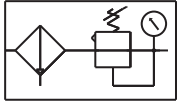

Code standard	Size	Thread	Filtration	Regulation	Flow Rate	Scarico
<a href="#">Y030 103 231 000</a>	FR 1	1/4"	20 µm	0 ÷ 8 bar	2000 NI/min	DEP
<a href="#">Y030 104 231 000</a>	FR 1	3/8"	20 µm	0 ÷ 8 bar	2000 NI/min	DEP
<a href="#">Y030 104 232 000</a>	FR 1	3/8"	20 µm	0 ÷ 8 bar	2000 NI/min	A
<a href="#">Y030 204 231 000</a>	FR 2	3/8"	20 µm	0 ÷ 8 bar	3000 NI/min	DEP
<a href="#">Y030 205 231 000</a>	FR 2	1/2"	20 µm	0 ÷ 8 bar	3000 NI/min	DEP
<a href="#">Y030 205 232 000</a>	FR 2	1/2"	20 µm	0 ÷ 8 bar	3000 NI/min	A
<a href="#">Y030 307 231 000</a>	FR 3	3/4"	20 µm	0 ÷ 8 bar	5800 NI/min	DEP
<a href="#">Y030 309 231 000</a>	FR 3	1"	20 µm	0 ÷ 8 bar	5800 NI/min	DEP
<a href="#">Y030 309 232 000</a>	FR 3	1"	20 µm	0 ÷ 8 bar	5800 NI/min	A

Code	Size	Thread	Filtration	Regulation	Exhaust	Manometer System
<b>Y 0 3 0</b>	<b>1</b>	<b>0 3</b>	<b>1</b>	<b>1</b>	<b>1</b>	<b>0 0 0</b>
<b>FRL1</b>	→ <b>03</b> = G 1/4 <b>04</b> = G 3/8	<b>1</b> = 5 µm <b>2</b> = 20 µm	<b>1</b> = 0÷2 bar (G1 - G2) <b>2</b> = 0÷4 bar (G1 - G2) <b>3</b> = 0÷8 bar (G1 - G2 - G3) <b>4</b> = 0÷12 bar (G1 - G2 - G3)	<b>1</b> = Depressure drain <b>2</b> = Adapter for manometer 1/8 Gas (Manometer not included)	<b>0</b> = Manometer incorporated <b>2</b> = Adapter for manometer 1/8 Gas (Manometer not included)	
<b>FRL2</b>	→ <b>04</b> = G 3/8 <b>05</b> = G 1/2					
<b>FRL3</b>	→ <b>07</b> = G 3/4 <b>09</b> = G 1					

### Regulator

Follow the indications below to set the pressure:

- 1 Raise the knob to the regulating position;
- 2 Set the desired pressure always in ascending manner;
- 3 Press the knob into the block position.

The knob can be padlocked to prevent tampering.



### Exhaust

**DEP** = The depressure drain condensate drain is normally in the open position, i.e. it automatically drains the condensate when there is no pressure in the bowl. By pressing the hose connector, it is also possible to drain the condensate when pressurised.

**A** = The automatic condensate drain with float, drains the condensate when the maximum level is reached, independently from the pressure used

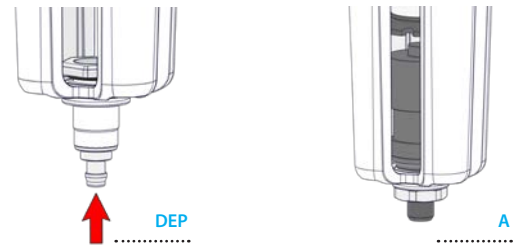

### Flow Characteristics

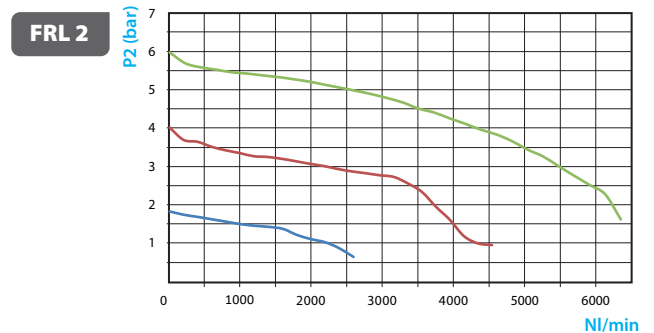
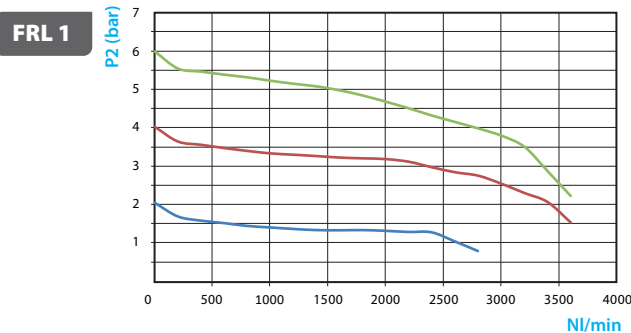

Inlet pressure

7 bar

Outlet pressure

P2 (bar)

Air flow

NI/min (20 °C - 1 bar)

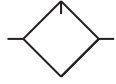

Code standard	Size	Thread	Flow Rate	Oil loading System
Y040 103 000 100	LUB 1	1/4"	3400 NI/min	M
Y040 104 000 100	LUB 1	3/8"	3400 NI/min	M
Y040 104 000 200	LUB 1	3/8"	3400 NI/min	A
Y040 204 000 100	LUB 2	3/8"	6100 NI/min	M
Y040 205 000 100	LUB 2	1/2"	6100 NI/min	M
Y040 205 000 200	LUB 2	1/2"	6100 NI/min	A
Y040 307 000 100	LUB 3	3/4"	11700 NI/min	M
Y040 309 000 100	LUB 3	1"	11700 NI/min	M
Y040 309 000 200	LUB 3	1"	11700 NI/min	A



**RECOMMENDED OILS: FRL 1, FRL 2, FRL 3**

Class ISO 22  
ISO 3448 norma

Code	Size	Thread	-	Oil loading Systema
------	------	--------	---	---------------------

Y 0 4 0

1

0 3

0 0 0

0 0 0

- FRL1 → 03 = G 1/4  
04 = G 3/8
- FRL2 → 04 = G 3/8  
05 = G 1/2
- FRL3 → 07 = G 3/4  
09 = G 1

1 = Manual  
2 = Automatic vacuum-operated

**LUBRICATOR**

**M =** The oil is introduced into the lubricator unit by unscrewing the cap on the upper surface or by removing the bowl; first making sure that there is no pressure in the plant. The oil in the circuit is adjusted by operating with a screwdriver on the pin and setting one drop of oil every 300-600 NI/min.

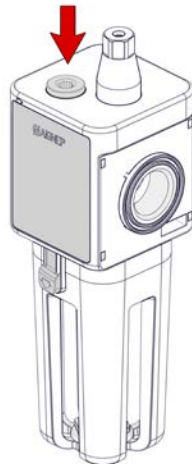

**LUBRICATOR**

**A =** The vacuum-operated oil loading allows the bowl to be filled automatically with oil. The system is activated by a button and the oil withdrawn from a tank, also positioned at lower heights with respect to the lubricator unit, flows into the bowl thanks to a G1/8 attachment positioned under the same. Loading must be interrupted when the oil reaches the maximum level allowed, corresponding to the transparent openings in the bowl.

Pushing start button for priming oil

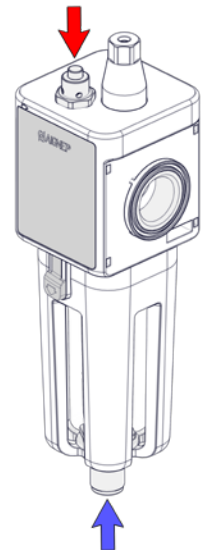

Priming of oil

## SERIES FRL EVO - Y050 SHUT OFF VALVE MANUAL - V3V - FRL1 / FRL2

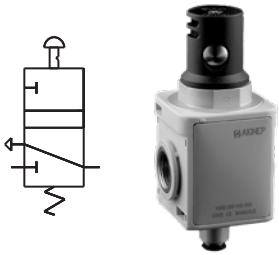

Code standard	Size	Thread	Flow Rate	Function	Drive	Max pressure
Y050 103 000 000	V3V 1	1/4	2700 NI/min	NC	M	10
Y050 104 000 000	V3V 1	3/8	2700 NI/min	NC	M	10
						10
Y050 204 000 000	V3V 2	3/8	3500 NI/min	NC	M	10
Y050 205 000 000	V3V 2	1/2	3500 NI/min	NC	M	10

Code	Size	Thread	-	-
------	------	--------	---	---

Y 0 5 0

1

0 3

0 0 0

0 0 0

FRL1 → 03 = G 1/4  
04 = G 3/8

FRL2 → 04 = G 3/8  
05 = G 1/2

### Functioning

The shut off valve is activated in the following phases:

- 1 By pressing the trigger switch 1, the primary circuit towards use opens.
- 2 By pressing button 2, the primary circuit closes and the secondary circuit drains.

The latter position can be padlocked.

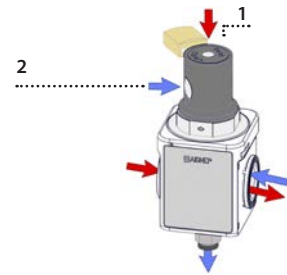

## SERIES FRL EVO - Y050 SHUT OFF VALVE MANUAL/SERVO - V3V - FRL3

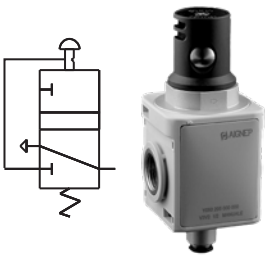

Code standard	Size	Thread	Flow Rate	Function	Drive	Press. Working
Y050 307 000 000	V3V 3	3/4"	6700 NI/min	NC	M/S	3 - 10 Bar
Y050 309 000 000	V3V 3	1"	6700 NI/min	NC	M/S	3 - 10 Bar

Code	Size	Thread	-	-
------	------	--------	---	---

Y 0 5 0

3

0 7

0 0 0

0 0 0

FRL3 → 07 = G 3/4  
09 = G 1

### Functioning

The shut off valve is activated in the following phases:

- 1 By pressing the trigger switch 1, the primary circuit towards use opens.
- 2 By pressing button 2, the primary circuit closes and the secondary circuit drains.

The latter position can be padlocked.

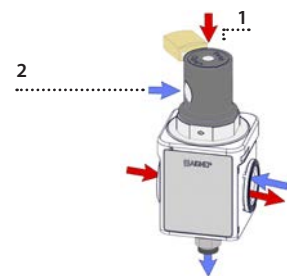

## SERIES FRL EVO - Y051 SHUT OFF VALVE PNEUMATIC - V3



Code standard	Size	Thread	Flow Rate	Function	Drive	Press. Min	Press. Max
Y051 104 000 000	V3V 1	3/8"	2700 NI/min	NC	P	2,5 Bar	10 Bar

Y051 205 000 000	V3V 2	1/2"	3500 NI/min	NC	P	2,5 Bar	10 Bar
------------------	-------	------	-------------	----	---	---------	--------

Code standard	Size	Thread	Flow Rate	Function	Drive	Press. Min	Press Inlet	Press. Min. Driving
Y051 309 000 000	V3V 3	1"	6700 NI/min	NC	P	13 Bar	2 Bar	2 Bar
							4 Bar	3,5 Bar
							6 Bar	4,7 Bar
							8 Bar	5,8 Bar
							10 Bar	7 Bar

Code	Size	Thread	-	Oil loading Systema
Y 0 5 1	1	0 3	0 0 0	0 0 0
	FRL1 →	03 = G 1/4 04 = G 3/8		1 = Manual 2 = Automatico a depressione
	FRL2 →	04 = G 3/8 05 = G 1/2		
	FRL3 →	07 = G 3/4 09 = G 1		

### Functioning - P

The pneumatic shut off valve is started in the following phases:

- 1 By pressurising the pilot "P", the primary circuit towards use opens;
- 2 By removing pressure from the operator "P", the primary circuit closes and the secondary circuit drains.

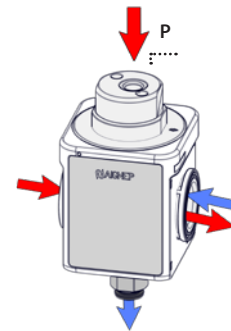

## SERIES FRL EVO - Y052 ELECTROPNEUMATIC SHUT OFF VALVE - V3V

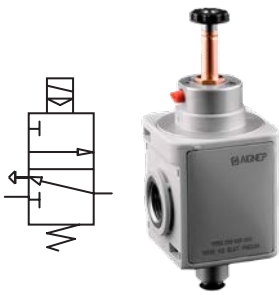

Code standard	Size	Thread	Flow Rate	Function	Drive
Y052 104 000 000	V3V 1	3/8"	2700 NI/min	NC	EP
Y052 205 000 000	V3V 2	1/2"	3500 NI/min	NC	EP
Y052 309 000 000	V3V 3	1"	6700 NI/min	NC	EP

EP = Electropneumatic - NC

\*NB: ATEX II 2GD Ex h TX category can be reclassified in accordance to the kind of solenoid applied. \*\*NB: Standard without solenoid

Code	Size	Thread	-	-
Y 0 5 2	1	0 3	0 0 0	0 0 0
	FRL1	→ 03 = G 1/4 04 = G 3/8		
	FRL2	→ 04 = G 3/8 05 = G 1/2		
	FRL3	→ 07 = G 3/4 09 = G 1		

### Functioning

The electro-pneumatic shut off valve is started in the following phases:

- 1 By activating the electric impulse, the primary circuit towards use opens;
- 2 By removing the electric impulse, the primary circuit closes and the secondary circuit drains.

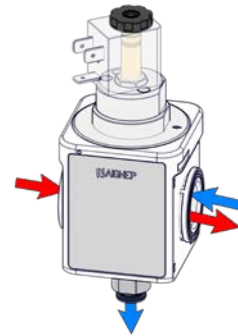













### Manual control position change:

- 1 Unscrew the two screws
- 2 Detach the top part and rotate 180°
- 3 Ensure that the two seals remain in place
- 4 Screw the two screws



SOL01 - COIL			SOLU1 - COIL			SOLX1 - COIL		
								
				<b>UL 1446 &amp; CSA C22.2</b>				II 3G Ex nA IIC T5 Gc   II 3D Ex tc IIIC 95°C Dc
Code	Voltage	Power	Code	Voltage	Power	Code	Voltage	Power
<a href="#">SOL01 012 C 1 000</a>	12V DC	3W	<a href="#">SOLU1 012 C 1 000</a>	12V DC	3W	<a href="#">SOLX1 012 C 1 000</a>	12V DC	3W
<a href="#">SOL01 024 C 1 000</a>	24V DC	3W	<a href="#">SOLU1 024 C 1 000</a>	24V DC	3W	<a href="#">SOLX1 024 C 1 000</a>	24V DC	3W
<a href="#">* SOL01 024 C 3 000</a>	24V DC	2W	<a href="#">* SOLU1 024 C 3 000</a>	24V DC	2W	<a href="#">SOLX1 024 A 2 000</a>	24V AC	5VA
<a href="#">SOL01 024 A 2 000</a>	24V AC	5VA	<a href="#">SOLU1 024 A 2 000</a>	24V DC	5VA	-	-	-
<a href="#">SOL01 110 A 2 000</a>	110V AC	5VA	<a href="#">SOLU1 110 A 2 000</a>	110V AC	5VA	-	-	-
<a href="#">SOL01 220 A 2 000</a>	220V AC	5VA	<a href="#">SOLU1 220 A 2 000</a>	220V AC	5VA	-	-	-
* Solenoid Recommended (ECO-FRIENDLY), only for 01V - 07V - 08V			* Solenoid Recommended (ECO-FRIENDLY), only for 01V - 07V - 08V					

CONNECTORS				
	Code	Size	Colour	Charateristics
	<a href="#">CON01 000 01</a>	22 mm	 BLACK	2 POLI
	<a href="#">CON02 024 00</a>	22 mm	 TRANSPARENT	● LED + VDR 0 - 24V
	<a href="#">CON02 110 00</a>	22 mm	 TRANSPARENT	● LED + VDR 110V
	<a href="#">CON02 250 00</a>	22 mm	 TRANSPARENT	● LED + VDR 220V
	<a href="#">*CONU1 000 01</a>	22 mm	 BLACK	2 PINS
	<a href="#">*CONU2 024 00</a>	22 mm	 TRANSPARENT	● LED + VDR 0 - 24V
	<a href="#">*CONU2 110 00</a>	22 mm	 TRANSPARENT	● LED + VDR 110V
	<a href="#">*CONU2 250 00</a>	22 mm	 TRANSPARENT	● LED + VDR 220V
* UL 1977 AND CAN/CSA C22.2 NO. 182.3				
VDR: Fitted with varistors as surge protection device.				

CONX1 - CONNECTORS				SOLX2 - COIL		
						
			II 2G Ex db mb IIC T5 Gb   II 2D Ex tb IIIC T5 Db			II 2G Ex e IIC T6 Gb   II 2D Ex tb IIIC T85°C Db
Code	Voltage	Colour	Charateristics	Code	Voltage	Power
<a href="#">CONX1 000 01</a>	22	 BLACK	2 POLI	<a href="#">SOLX2 012 C 1 000</a>	12V DC	3W
-	-	-	-	<a href="#">SOLX2 024 C 1 000</a>	24V DC	3W
-	-	-	-	<a href="#">SOLX2 024 A 2 000</a>	24V DC	4,8VA
-	-	-	-	<a href="#">SOLX2 110 A 2 000</a>	110V AC	4,8VA
-	-	-	-	<a href="#">SOLX2 220 A 2 000</a>	220V AC	4,8VA
				Do not use with 01VB bases		
				With 08V NAMUR valves use the 08V01 spacer		

## SERIES FRL EVO - Y060 SOFT START VALVE - V3V

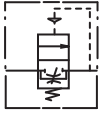

Code standard	Size	Thread	Flow Rate	Press. Max
Y060 103 000 000	APE 1	1/4"	2700 NI/min	10 Bar
Y060 104 000 000	APE 1	3/8"	2700 NI/min	10 Bar
Y060 204 000 000	APE 2	3/8"	3500 NI/min	10 Bar
Y060 205 000 000	APE 2	1/2"	3500 NI/min	10 Bar
Y060 307 000 000	APE 3	3/4"	6700 NI/min	10 Bar
Y060 309 000 000	APE 3	1"	6700 NI/min	10 Bar

Code	Size	Thread	-	-
Y 0 6 0	1	0 3	0 0 0	0 0 0
FRL1	→	03 = G 1/4 04 = G 3/8		
FRL2	→	04 = G 3/8 05 = G 1/2		
FRL3	→	07 = G 3/4 09 = G 1		

### The soft start valve

The soft start valve is a pneumatic device that allows the pneumatic plants to be pressurised gradually. It is possible to lengthen or shorten the pressure increase time via the adjustment screw 1

1 The soft start valve has been designed in a way to have complete opening of the circuit on reaching 50% of the inlet pressure.



## SERIES FRL EVO - Y090 AIR DISTRIBUTOR



Code standard	Size	Thread	Flow Rate
<a href="#">Y090 103 030 000</a>	DIS 1	1/4" - 1/4"	3400 NI/min
<a href="#">Y090 104 030 000</a>	DIS 1	3/8" - 1/4"	3400 NI/min
<a href="#">Y090 104 040 000</a>	DIS 1	3/8" - 3/8"	3400 NI/min
<a href="#">Y090 204 030 000</a>	DIS 2	3/8" - 1/4"	6100 NI/min
<a href="#">Y090 204 040 000</a>	DIS 2	3/8" - 3/8"	6100 NI/min
<a href="#">Y090 205 030 000</a>	DIS 2	1/2" - 1/4"	6100 NI/min
<a href="#">Y090 205 050 000</a>	DIS 2	1/2" - 1/2"	6100 NI/min
<a href="#">Y090 307 070 000</a>	DIS 3	3/4" - 3/4"	11700 NI/min
<a href="#">Y090 309 090 000</a>	DIS 3	1" - 1"	11700 NI/min

Code	Size	Thread X	Thread Y	-
<b>Y 0 9 0</b>	<b>1</b>	<b>0 3</b>	<b>0 3</b>	<b>0 0 0 0</b>
FRL1	→	03 = G 1/4 04 = G 3/8	→	03 = 1/4 04 = 3/8
FRL2	→	04 = G 3/8 05 = G 1/2	→	03 = 1/4 04 = 3/8 05 = 1/2
FRL3	→	07 = G 3/4 09 = G 1	→	07 = 3/4 09 = 1

### Functioning

The distributor allows the branching of several connections and allows the use of appliances, for example (pressure switches and switches). The distributor can be introduced into every position of the air treatment unit.

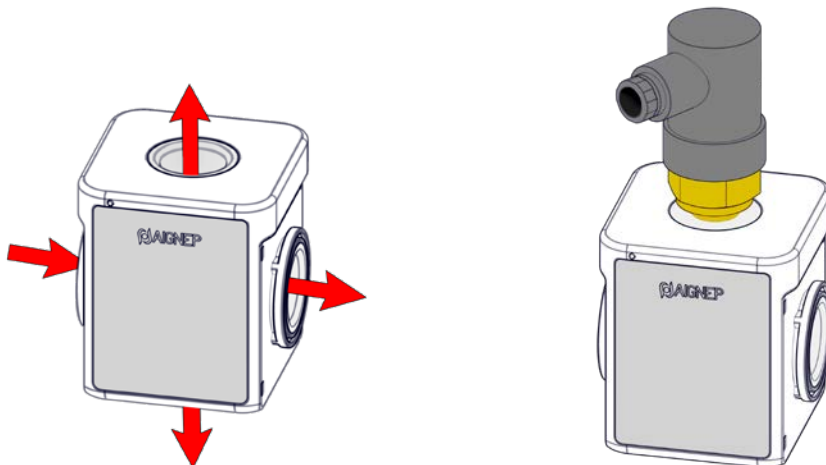

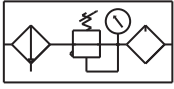

Code standard	Size	Thread	Filtration	Regulation	Flow Rate	Exhaust
<b>Y100 103 231 100</b>	FR+L1	1/4"	20 µm	0 ÷ 8 bar	1500 NI/min	DEP
<b>Y100 104 231 100</b>	FR+L1	3/8"	20 µm	0 ÷ 8 bar	1500 NI/min	DEP
<b>Y100 104 232 100</b>	FR+L1	3/8"	20 µm	0 ÷ 8 bar	1500 NI/min	A
<b>Y100 204 231 100</b>	FR+L2	3/8"	20 µm	0 ÷ 8 bar	2700 NI/min	DEP
<b>Y100 205 231 100</b>	FR+L2	1/2"	20 µm	0 ÷ 8 bar	2700 NI/min	DEP
<b>Y100 205 232 100</b>	FR+L2	1/2"	20 µm	0 ÷ 8 bar	2700 NI/min	A
<b>Y100 307 231 100</b>	FR+L3	3/4"	20 µm	0 ÷ 8 bar	5200 NI/min	DEP
<b>Y100 309 231 100</b>	FR+L3	1"	20 µm	0 ÷ 8 bar	5200 NI/min	DEP
<b>Y100 309 232 100</b>	FR+L3	1"	20 µm	0 ÷ 8 bar	5200 NI/min	A

Code	Size	Thread	Filtration	Regulation	Exhaust	Oil loading System	Manometer System
<b>Y 1 0 0</b>	<b>1</b>	<b>0 3</b>	<b>1</b>	<b>1</b>	<b>1</b>	<b>0</b>	<b>0</b>
	FRL1 →	03 = G 1/4 04 = G 3/8	1 = 5 µm 2 = 20 µm	1 = 0÷2 bar (G1 -G2) 2 = 0÷4 bar (G1 - G2) 3 = 0÷8 bar (G1 - G2 - G3) 4 = 0÷12 bar (G1 - G2 - G3)	1 = Depressure drain 2 = Automatic with float (max 8 bar)	1 = Manual 2 = Automatic vacuum-operated	0 = Manometer incorporated 2 = Adapter for manometer G1/8 (Manometer not included)
	FRL2 →	04 = G 3/8 05 = G 1/2					
	FRL3 →	07 = G 3/4 09 = G 1					

### Regulator

Follow the indications below to set the pressure:

- 1 Raise the knob to the regulating position;
- 2 Set the desired pressure always in ascending manner;
- 3 Press the knob into the block position.

The knob can be padlocked to prevent tampering.

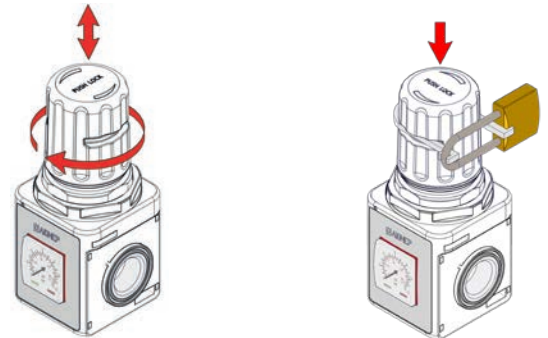

### Exhaust

**DEP** = The depressure drain condensate drain is normally in the open position, i.e. it automatically drains the condensate when there is no pressure in the bowl. By pressing the hose connector, it is also possible to drain the condensate when pressurised.

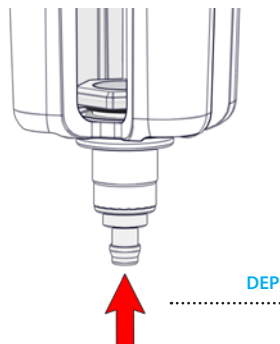

### Exhaust

**A** = The automatic condensate drain with float, drains the condensate when the maximum level is reached, independently from the pressure used

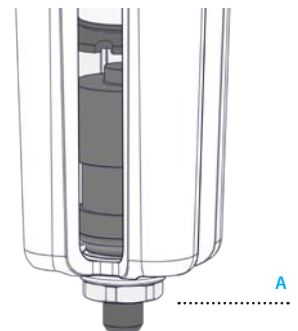

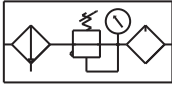

Code standard	Size	Thread	Filtration	Flow Rate
<a href="#">Y400 103 401 000</a>	FIL+FC 1	1/4"	5 µm + 0.01 µm	600 NI/min
<a href="#">Y400 104 401 000</a>	FIL+FC 1	3/8"	5 µm + 0.01 µm	600 NI/min
<a href="#">Y400 204 401 000</a>	FIL+FC 2	3/8"	5 µm + 0.01 µm	750 NI/min
<a href="#">Y400 205 401 000</a>	FIL+FC 2	1/2"	5 µm + 0.01 µm	750 NI/min
<a href="#">Y400 307 401 000</a>	FIL+FC 3	3/4"	5 µm + 0.01 µm	1400 NI/min
<a href="#">Y400 309 401 000</a>	FIL+FC 3	1"	5 µm + 0.01 µm	1400 NI/min

Code	Size	Thread	Filtration	Condensate exhaust System	-
------	------	--------	------------	---------------------------	---

**Y 4 0 0**

**1**

**0 3**

**4**

**0**

**1**

**0 0 0**

- FRL1 → **03** = G 1/4  
**04** = G 3/8
- FRL2 → **04** = G 3/8  
**05** = G 1/2
- FRL3 → **07** = G 3/4  
**09** = G 1

4 = 0.01 µm

- 1 = A depressione
- 2 = Automatico a galleggiante (max 8 bar)

**Exhaust**

**DEP =** The depressure drain condensate drain is normally in the open position, i.e. it automatically drains the condensate when there is no pressure in the bowl. By pressing the hose connector, it is also possible to drain the condensate when pressurised.

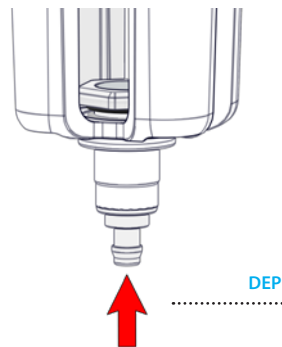

**Exhaust**

**A =** The automatic condensate drain with float, drains the condensate when the maximum level is reached, independently from the pressure used

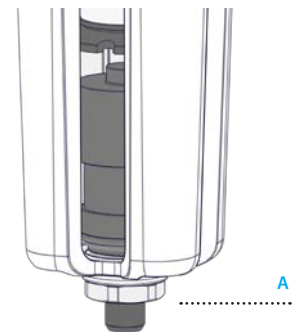

**Informations**

Coalescer cartridge is made of microfiber layer with external stainless steel structure. Coalescing cartridge uses inertial impact, interception and coalescence to gather liquid particles into drops.

These drops will fall into bowl bottom.

Coalescing Filter is used as Oil Separator which removes oil-vapours from air output. We recommend to install a 5 µm Filter upstream to protect coalescing filter from choking of cartridge.

**COALESCER CARTRIDGE**

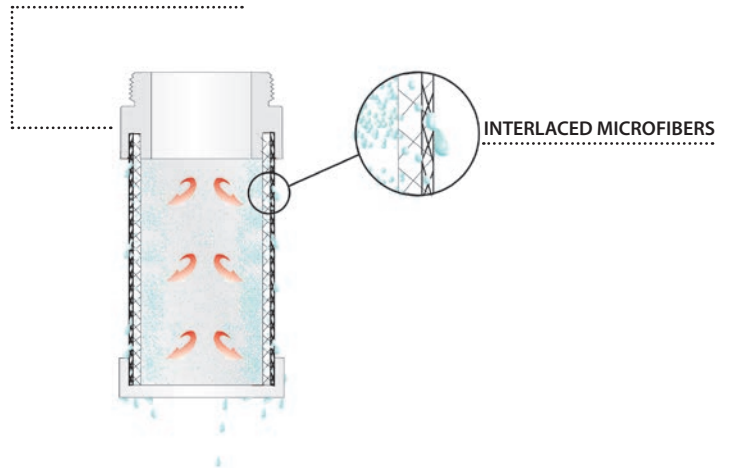

### CLAMP BRACKET



Code

- [REG16 1Y 50 00 ZI](#)
- [REG16 2Y 50 00 ZI](#)
- [REG16 3Y 50 00 ZI](#)

- FRL 1
- FRL 2
- FRL 3

### Y501 - CONNECTION UNIT FOR WALL ATTACHMENT

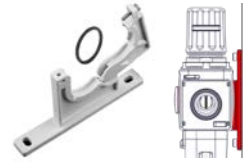

Code

- [Y501 100 000 000](#)
- [Y501 200 000 000](#)
- [Y501 300 000 000](#)

- FRL 1
- FRL 2
- FRL 3

### Y502 - CONNECTION UNIT



Code

- [Y502 100 000 000](#)
- [Y502 200 000 000](#)
- [Y502 300 000 000](#)

- FRL 1
- FRL 2
- FRL 3

### Connection unit

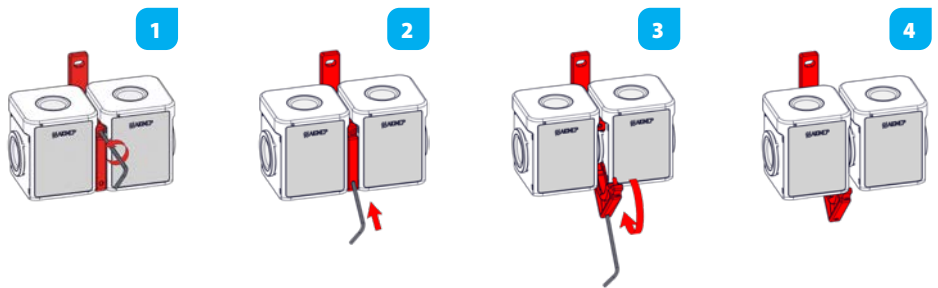

### SIDE HITCH ADAPTER KIT



Code

- [Y504 100 000 000](#)
- [Y504 200 000 000](#)

- FRL 1
- FRL 2

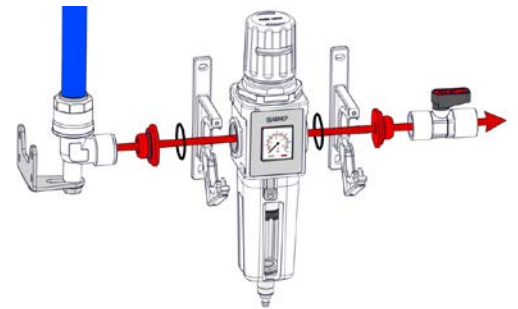

It's recommended to use the sealant on the thread

### COALESCER FILTER CARTRIDGE



Code

- [T546 10Y 000 000](#)
- [T546 20Y 000 000](#)
- [T546 30Y 000 000](#)

- FRL 1
- FRL 2
- FRL 3



### ACTIVE CARBON FILTER CARTRIDGE



Code

- [T545 10Y 000 000](#)
- [T545 20Y 000 000](#)
- [T545 30Y 000 000](#)

- FRL 1
- FRL 2
- FRL 3

SINTERED FILTER			BOWL FOR FILTER UNIT			BOWL FOR LUBRICATOR UNIT			MANOMETER		
Code			Code			Code			Code		
											
	μm			μm						Bar	
<a href="#">FIL04 1Y3 805 SC</a>	FRL 1	5	<a href="#">Y520 100 001 000</a>	FRL 1	DEP	<a href="#">Y530 100 000 100</a>	FRL1	MAN	<a href="#">MAS1 1N0 020 000</a>	FRL1	0-4
<a href="#">FIL04 1Y3 820 SC</a>	FRL 1	20	<a href="#">Y520 100 002 000</a>	FRL1	A	<a href="#">Y530 100 000 200</a>	FRL1	A	<a href="#">MAS1 1N0 040 000</a>	FRL1	0-12
<a href="#">FIL04 2Y3 805 SC</a>	FRL 2	5	<a href="#">Y520 200 001 000</a>	FRL2	DEP	<a href="#">Y530 200 000 100</a>	FRL2	MAN	<a href="#">MAS1 2N0 020 000</a>	FRL2	0-4
<a href="#">FIL04 2Y3 820 SC</a>	FRL 2	20	<a href="#">Y520 200 002 000</a>	FRL2	A	<a href="#">Y530 200 000 200</a>	FRL2	A	<a href="#">MAS1 2N0 040 000</a>	FRL2	0-12
<a href="#">FIL04 3Y3 805 SC</a>	FRL 3	5	<a href="#">Y520 300 001 000</a>	FRL3	DEP	<a href="#">Y530 300 000 100</a>	FRL3	MAN	<a href="#">MAS1 3N0 040 000</a>	FRL3	0-12
<a href="#">FIL04 3Y3 820 SC</a>	FRL 3	20	<a href="#">Y520 300 002 000</a>	FRL3	A	<a href="#">Y530 300 000 200</a>	FRL3	A	-	-	-



**ADAPTER FOR MANOMETER 1/8**



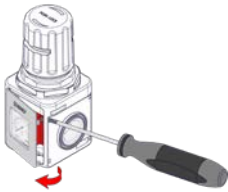

Code

<a href="#">MAS0 102 000 000</a>	FRL 1	G 1/8
<a href="#">MAS0 202 000 000</a>	FRL 2	G 1/8
<a href="#">MAS0 302 000 000</a>	FRL 3	G 1/8

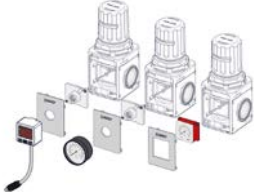
**Adapter for manometer 1/8**



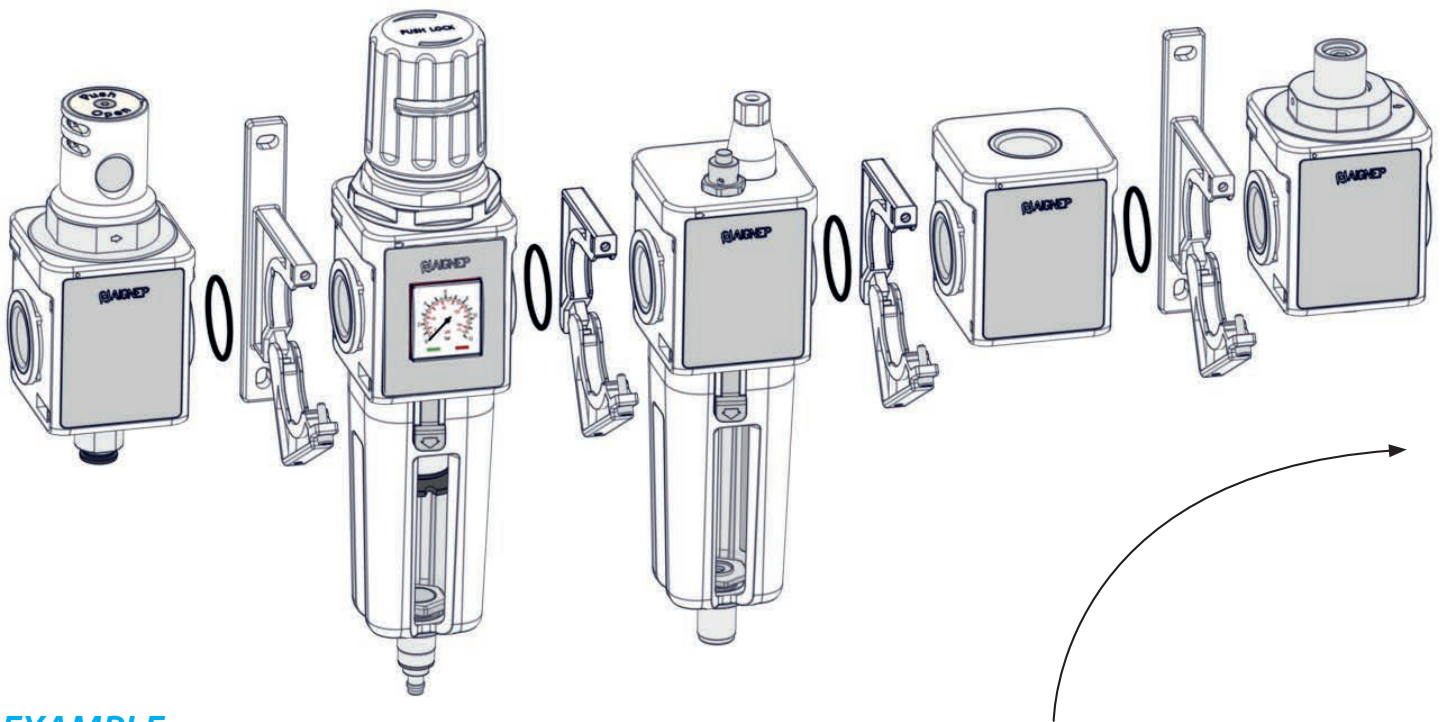

PADLOCK FOR ADJUSTER AND ADJUSTER FILTER KIT			PADLOCK	
Code			Code	
				
<a href="#">MAS0 102 000 000</a>	FRL 1	G 1/8	<a href="#">LUC01 00 001</a>	20 mm
<a href="#">MAS0 202 000 000</a>	FRL 2	G 1/8	-	FRL 2
<a href="#">MAS0 302 000 000</a>	FRL 3	G 1/8	-	FRL 3

# SET YOUR FRL EVO

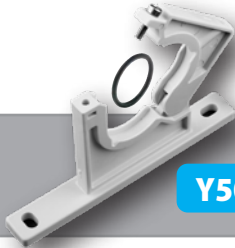

## EXAMPLE:





**Y501**



**Y502**

	CODE ELEMENTS		
1° POS	Y050 103 000 000	+	→
		<input type="checkbox"/>	<input checked="" type="checkbox"/>
2° POS	Y030 103 231 000		

Introduce the element code and accessory code into the table below to configure your FRL Evo

 Y501	 Y502
<input type="checkbox"/>	<input checked="" type="checkbox"/>
<input checked="" type="checkbox"/>	<input type="checkbox"/>
<input type="checkbox"/>	<input checked="" type="checkbox"/>

# SET YOUR FRL EVO

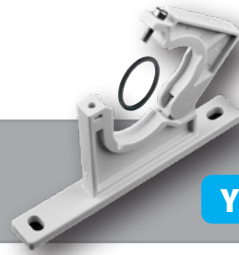

**Y501**



**Y502**

	CODE ELEMENTS		
1° POS	-----		
	+      →	<input type="checkbox"/>	<input type="checkbox"/>
2° POS	-----		
	+      →	<input type="checkbox"/>	<input type="checkbox"/>
3° POS	-----		
	+      →	<input type="checkbox"/>	<input type="checkbox"/>
4° POS	-----		
	+      →	<input type="checkbox"/>	<input type="checkbox"/>
5° POS	-----		
	+      →	<input type="checkbox"/>	<input type="checkbox"/>
6° POS	-----		
	+      →	<input type="checkbox"/>	<input type="checkbox"/>
7° POS	-----		
	+      →	<input type="checkbox"/>	<input type="checkbox"/>
8° POS	-----		
	+      →	<input type="checkbox"/>	<input type="checkbox"/>
9° POS	-----		
	+      →	<input type="checkbox"/>	<input type="checkbox"/>
10° POS	-----		

## MANOMETER BACK CONNECTION



Reference standard

EN 837-1



Fluid

Air / Inert gases / Steam / Non-highly viscose and non-crystallizing liquids



Threads

Tapered gas in conformity with ISO7.1, BS 21, DIN 2999.



Temperature

- 20 °C  
+ 60 °C



Code	Bar	Code	Bar	Code	Bar
<a href="#">MAN01 N2 020 000</a>	0 ÷ 4	<a href="#">MAN01 N2 060 000</a>	0 ÷ 10	<a href="#">MAN02 N2 050 000</a>	0 ÷ 6
<a href="#">MAN01 N2 050 000</a>	0 ÷ 6	<a href="#">MAN01 N2 040 000</a>	0 ÷ 12	<a href="#">MAN02 N2 040 000</a>	0 ÷ 12

## MANOMETER BOTTOM CONNECTION



Reference standard

EN 837-1



Fluid

Air / Inert gases / Steam / Non-highly viscose and non-crystallizing liquids



Threads

Tapered gas in conformity with ISO7.1, BS 21, DIN 2999.



Temperature

- 40 °C  
+ 60 °C



Code	Bar	Code	Bar	Code	Bar
<a href="#">MAN03 N2 050 000</a>	0 ÷ 6	<a href="#">MAN03 N2 040 000</a>	0 ÷ 12	<a href="#">MAN04 N2 040 000</a>	0 ÷ 12

## MANOMETER BACK CONNECTION FOR PANEL MOUNTING WITH BRACKET, CHROMED FLANGE



Reference standard

EN 837-1



Fluid

Air / Inert gases / Steam / Non-highly viscose and non-crystallizing liquids



Threads

Tapered gas in conformity with ISO7.1, BS 21, DIN 2999.



Temperature

- 40 °C  
+ 60 °C



Code	Bar	Code	Bar
<a href="#">MAN05 N2 020 000</a>	0 ÷ 4	<a href="#">MAN05 N2 060 000</a>	0 ÷ 10
<a href="#">MAN05 N2 050 000</a>	0 ÷ 6	<a href="#">MAN05 N2 040 000</a>	0 ÷ 12

## MANOMETER BACK CONNECTION, 3 HOLES CHROMED FLANGE



Reference standard

EN 837-1



Fluid

Air / Inert gases / Steam / Non-highly viscose and non-crystallizing liquids



Threads

Tapered gas in conformity with ISO7.1, BS 21, DIN 2999.



Temperature

- 40 °C  
+ 60 °C



Code	Bar	Code	Bar
<a href="#">MAN06 N2 020 000</a>	0 ÷ 4	<a href="#">MAN06 N2 060 000</a>	0 ÷ 10
<a href="#">MAN06 N2 050 000</a>	0 ÷ 6	<a href="#">MAN06 N2 040 000</a>	0 ÷ 12

## DIAPHRAGM PRESSURE SWITCH ≤ 250V

<b>REFERENCE STANDARD</b>		<b>MAX SAFETY PRESSURE</b>	80 bar
<b>FLUID</b>	Gas, Air, Water, Oil, Petrol, Solvents, Silicone	<b>DRIVE TIP</b>	1 B
<b>MAX WORKING PRESSURE</b>	40 bar	<b>MECHANICAL LIFE</b>	1 MILLION CYCLE
<b>MAX TEMPERATURE FLUID</b>	120 °C	<b>ELETRICAL LIFE</b>	100.000 CYCLE
<b>MAX SWITCHING TENSION</b>	250V	<b>ELETRICAL CONTACTS</b>	SILVER AgNi
		<b>MAX SWITCHING VOLTAGE</b>	0,5 A

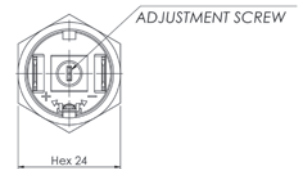
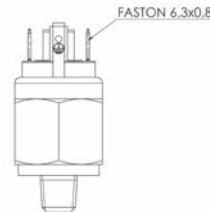
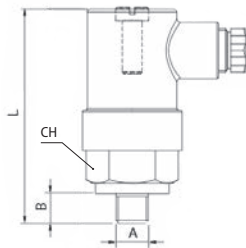

Series	Functione	Thread taper	Regulation range
<b>P 3</b>	<b>1</b> 1 = NO 2 = NC	<b>1 8</b> 18 = 1/8 14 = 1/4	<b>0 1</b> 01 = 0,1 ÷ 1 bar 02 = 1 ÷ 10 bar 03 = 10 ÷ 20 bar

Code	Functione	Regulation	Tolerance 20°C
P311801	NO	0.1 ÷ 1 bar	± 0.1 bar
P311802	NO	1 ÷ 10 bar	± 0.5 bar
P311803	NO	10 ÷ 20 bar	± 1.0 bar
P311401	NO	0.1 ÷ 1 bar	± 0.1 bar
P311402	NO	1 ÷ 10 bar	± 0.5 bar
P311403	NO	10 ÷ 20 bar	± 1.0 bar
P321801	NC	0.1 ÷ 1 bar	± 0.1 bar
P321802	NC	1 ÷ 10 bar	± 0.5 bar
P321803	NC	10 ÷ 20 bar	± 1.0 bar
P321401	NC	0.1 ÷ 1 bar	± 0.1 bar
P321402	NC	1 ÷ 10 bar	± 0.5 bar
P321403	NC	10 ÷ 20 bar	± 1.0 bar

## DIAPHRAGM PRESSURE SWITCH - ADJUSTABLE HYSTERESIS - EXCHANGE CONTACTS

<b>REFERENCE STANDARD</b>	<div style="display: flex; justify-content: space-around;"> <div style="border: 1px solid gray; padding: 2px; text-align: center;">1907/2006 <b>REACH</b> ✓</div> <div style="border: 1px solid gray; padding: 2px; text-align: center;">2011/65/CE <b>RoHS</b> ✓</div> </div> <div style="display: flex; justify-content: space-around; margin-top: 10px;"> <div style="border: 1px solid gray; padding: 2px; text-align: center;">PED 2014/68/UE</div> <div style="border: 1px solid gray; padding: 2px; text-align: center; font-weight: bold; font-size: 1.2em;">IP65</div> </div>	<b>DRIVE TIPY</b>	1 B
<b>FLUID</b>	Gas, Air, Water, Oil, Petrol, Solvents, Silicone	<b>MECHANICAL LIFE</b>	1 MILLION CYCLE
<b>REGULATION PIN</b>	1.5mm ALLEN WRENCH	<b>ELETRICAL CONTACTS</b>	SILVER AgNi
<b>MAX WORKING PRESSURE</b>	40 bar	<b>ELETRICAL FEATURES</b>	5 (4) A / 14 Vdc 4 (3) A / 30 Vdc 5 (3) A / 125 Vac 3 (2) A / 250 Vac
<b>MAX TEMPERATURE FLUID</b>	120 °C	<b>ELETRICAL CONDITION</b>	SPDT CONTACTS
<b>MAX SWITCHING VOLTAGE</b>	0,5 A	<b>MAX TORQUE</b>	25/50 Nm
<b>MAX SAFETY PRESSURE</b>	80 bar	<b>HYSTERESIS</b>	10 ÷ 30 %

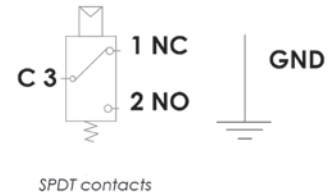
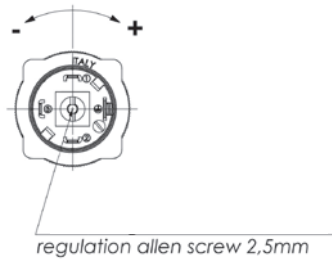

Series	Thread taper	Regulation range
--------	--------------	------------------

<b>P 2 7</b>	<b>1 8</b>	<b>0 1</b>
	18 = 1/8 14 = 1/4	01 = 0,3 ÷ 1,5 bar 02 = 1 ÷ 10 bar 03 = 10 ÷ 50 bar

Code	Regulation	Tolerance 20°C
P27 18 01	0,3 ÷ 1,5 bar	± 0,20 bar
P27 18 02	1 ÷ 10 bar	± 0,50 bar
*P27 18 03	10 ÷ 50 bar	± 2,00 bar
P27 14 01	0,3 ÷ 1,5 bar	± 0,20 bar
P27 14 02	1 ÷ 10 bar	± 0,50 bar
*P27 14 03	10 ÷ 50 bar	± 2,00 bar

\* BODY: Stainless

## DIAPHRAGM PRESSURE SWITCH WITH EXCHANGE CONTACTS

<b>REFERENCE STANDARD</b>	1907/2006 2011/65/CE	<b>DRIVE TIPY</b>	1 B
	PED 2014/68/UE IP65		<b>MECHANICAL LIFE</b>
<b>FLUID</b>	Gas, Air, Water, Oil, Petrol, Solvents, Silicone	<b>ELETRICAL CONTACTS</b>	SILVER AgNi
<b>MAX WORKING PRESSURE</b>	40 bar	<b>ELETRICAL FEATURES</b>	4 (2) A / 24 Vdc 6 (2) A / 250 Vac
<b>MAX TEMPERATURE FLUID</b>	120 °C	<b>ELETRICAL CONDITION</b>	SPDT CONTACTS
<b>MAX SAFETY PRESSURE</b>	80 bar / Stainless 300 bar	<b>HYSTERESIS</b>	10 ÷ 50 % Adjustable

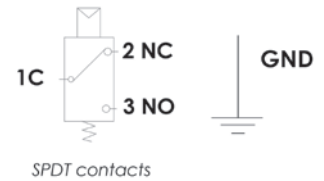
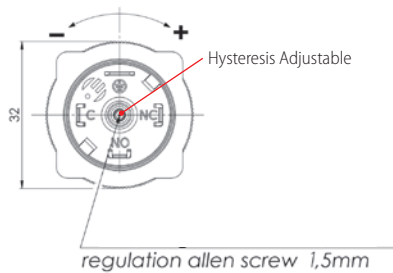

Series

Thread taper

Regulation range

**P 4 9**

**1 8**

**0 1**

18 = 1/8  
14 = 1/4

01 = 0,3 ÷ 1,5 bar  
02 = 1 ÷ 12 bar  
03 = 10 ÷ 60 bar

Code	Regulation	Tolerance 20°C
P49 18 01	0.3 ÷ 1.5 bar	± 0.15 bar
P49 18 02	1 ÷ 12 bar	± 0.50 bar
P49 18 03	10 ÷ 60 bar	± 2.00 bar
P49 14 01	0.3 ÷ 1.5 bar	± 0.15 bar
P49 14 02	1 ÷ 12 bar	± 0.50 bar
P49 14 03	10 ÷ 60 bar	± 2.00 bar



REFERENCE STANDARD

1907/2006  
REACH ✓

2011/65/CE  
RoHS ✓

Series	Regulation range	Thread conico	Output
--------	------------------	---------------	--------

**P R 0 3**

**0 1**

**0 3**

**P 1**

- 1 = 0 - 100 l/min → **03** = R 1/4
- 2 = 0 - 200 l/min → **03** = R 1/4
- 5 = 2 - 500 l/min → **05** = G 1/2
- 20 = 10 - 2000 l/min → **07** = G 3/4

- P1** = PNP + Analogic (1-5V)
- P2** = PNP + Analogic (4-20mA)

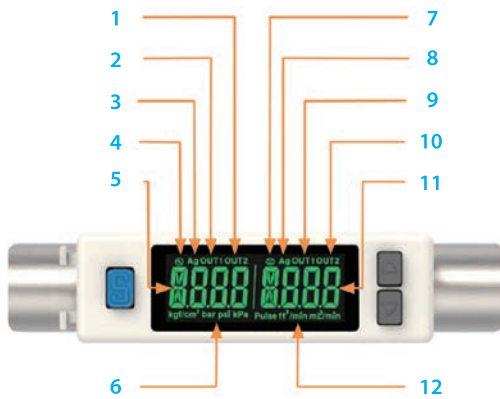

LENGTH: 2 MT.



- |    |                                 |
|----|---------------------------------|
| 1  | Output 2 indicator              |
| 2  | Output 1 indicator              |
| 3  | Analog signal indicator         |
| 4  | Pressure symbol                 |
| 5  | Pressure display                |
| 6  | Pressure unit (display section) |
| 7  | Flow symbol                     |
| 8  | Analog signal indicator         |
| 9  | Output 1 indicator              |
| 10 | Output 2 indicator              |
| 11 | Flow display                    |
| 12 | Flow unit (display section)     |
| 13 | Button                          |
| 14 | 3 Color LCD display             |
| 15 | Setting button                  |
| 16 | Connector                       |
| 17 | Piping port (IN side)           |
| 18 | Piping port (OUT side)          |

## Code and output circuit wiring diagrams

Pin No.	Line color	Content
1	Brown	Power supply ( 12 ~ 24 V DC )
2	Orange	Analog voltage output : 1 ~ 5 V Analog current output : 4 ~ 20 mA
3	Yellow	External input
4	Black	Output 1 ( Max. load current : 125 mA )
5	White	Output 2 ( Max. load current : 125 mA )
6	Blue	0 V ( GND )

### PNP Output / Analog Voltage Output / External Input

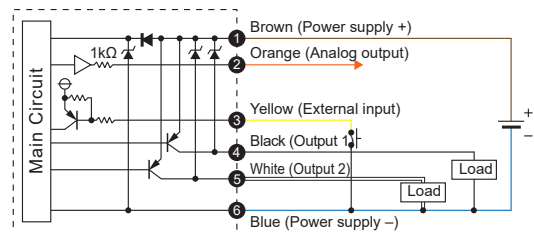

### PNP Output / Analog Current Output / External Input

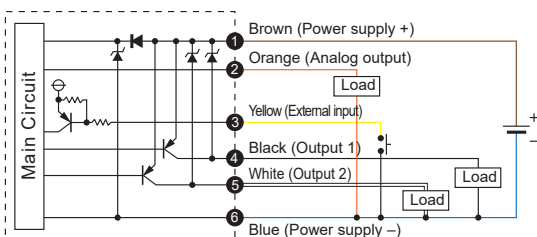

PR03 01-02

PR03 05

Mounting Screw

P Type  
Size : 3.0  
Length : 6

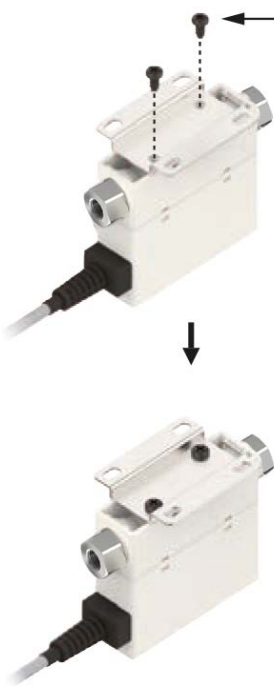

**PR03B01**

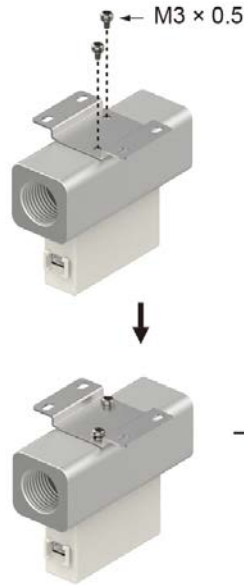
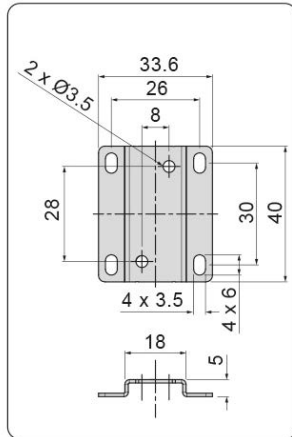

**PR03B05**

Mounting Bracket

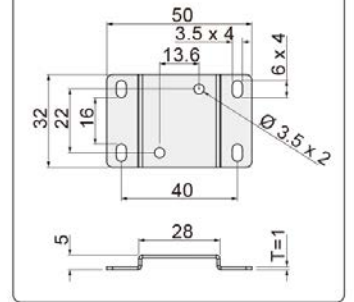

PR03 20



**PR03B20**

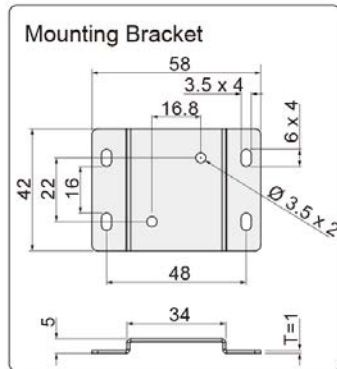

MODEL		PR030103	PR030203	PR030505	PR032007
Fluid (Unidirection)		Filtered air, Non-corrosive / Non-flammable gas			
Rated pressure range		0.9 ~ 8 Bar	0.9 ~ 8 Bar	0.9 ~ 10 Bar	0.9 ~ 10 Bar
Display	Rated pressure range	4 Digital, 7 segment LCD display (Red/Green/Orange)			
	Instant flow rate	Display range: 0 ~ 105 L/min Minium setting scale : 0.1 L/min	Display range: 0 ~ 210 L/min Minium setting scale : 1 L/min	Display range: 0 ~ 525 L/min Minium setting scale : 1 L/min	Display range: 0 ~ 2100 L/min Minium setting scale : 1 L/min
	Accumulated flow	Display range: 99999999 L Minium setting scale : 0.1 L/min	Display range: 99999999 L Minium setting scale : 1 L/min	Display range: 99999999 L Minium setting scale : 1 L/min	Display range: 99999999 L Minium setting scale : 1 L/min
	Pressure display	Display range: -1 ~ 10 Bar Minium setting scale : 0.01 L/min			
Flow Rate	Sensor elements	0 ~ 100 L/min	0 ~ 200 L/min	2 ~ 500 L/min	10 ~ 2000 L/min
	Guaranteed range	2 ~ 100% F.S.			
	Indicator accuracy	± 3% F.S. / ± 1 digit			
	Analog output accuracy	± 5% F.S.			
	Repeatability	± 1% F.S. / ± 1 digit			
	Linearity	± 3% F.S.			
	Temperature characteristic	± 2% / ± 5% (15~35 °C) / (0~15°C / 35~50°C)	± 2% / ± 5% (15~35 °C) / (0~15°C / 35~50°C)	± 5%	± 5%
	Pressure characteristic	± 5% F.S. / ± 1 digit			
	Response time	800 ms			
	Output mode	Hysteresis mode, Window comparator mode, Accumulated output, Accumulated pulse output			
Power	Power supply voltage	12 ~ 24 V DC ± 10%			
	Current consumption	≤ 50 mA			
Pressure	Guaranteed range	0 ~ 100 %			
	Indicator accuracy	± 2% F.S. / ± 1 digit			
	Analog output accuracy	± 2.5% F.S.			
	Repeatability	± 0.2% F.S. / ± 1 digit			
	Linearity	± 1% F.S.			
	Temperarature characteristic	± 2% F.S.			
	Response time	2.5 ms			
	Output mode	One point set mode, Hysteresis mode, Window comparator mode			
Accumulated pulse output		1 L/Pulse	2 L/Pulse	5 L/Pulse	10 L/Pulse
Hysteresis		Adjustable			
Switch output		2 PNP: Open collector 2 outputs Max. Load current: 125 mA Max. Supply Voltage: 24 V DC Voltage Drop: ≤ 1.5 V		(On request) 2 NPN: Open collector 2 outputs Max. Load current: 125 mA Max. Supply Voltage: 28 V DC Voltage Drop: ≤ 1.5 V	

MODEL		PR030103	PR030203	PR030505	PR032007
Analog output	Voltage and Current Output	1 ~ 5 V - 1 K $\Omega$ 4 ~ 20 mA - 300 K $\Omega$			
	Response time	Pressure: $\leq$ 50 ms Flow $\leq$ 100 ms			
Environment	IP enclosure	IP40			
	Ambient temp.range	Operation: 0 ~ 50°C, Storage:-10 ~ 60°C (No condensation or freezing)			
	Ambient humidity range	Operation/Storage: 35 ~ 85% RH (No condensation)			
	Withstand voltage	1000V AC in 1-min (between case and lead wire)			
	Insulation resistance	50M $\Omega$ . (at 500V DC, between case and lead wire)		2M $\Omega$ . (at 50V DC, between case and lead wire)	
	Vibration	Total amplitude 1.5mm or 10G, 10Hz-55Hz-10Hz scan for 1 minute, 2 hours each direction of X, Y and Z			
	Shock	100m/s <sup>2</sup> (10G), 3 times each in direction of X, Y and Z			
	Withstand pressure	1 MPa 10 Bar			
	Working fluid temperature	0 ~ 50°C (No condensation or freezing)			
Lead wire		Ø4 Oil resistance cable (PVC) - 26 AWG (0.15mm) - 6 cores			



REFERENCE STANDARD

- 1907/2006 REACH ✓
- 2011/65/CE RoHS ✓

Easy unit identification

- Conversion unit is on display and easy to read



Quick installation

- Save installation time
- Easy removal

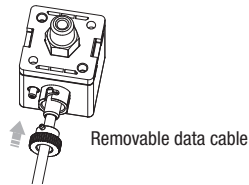

2-Color display

- User programmable color mode, for different dsetting conditions



Copy setting

- Avoid setting errors
- Reduce setting time



IP65 Enclosure

- Protected against water and dust splash from all directions



1	Output 1 indicator
2	Output 2 indicator
3	Up/Down button
4	Setting button
5	Pressure Unit display section
6	2 color display



**Code and output circuit wiring diagrams**

PR02 P 02 P1 (pressure)  
PR02 V 02 P1 (Vacuum)

PR02 P 02 P2 (pressure)  
PR02 V 02 P2 (Vacuum)

PR02 P 02 PC (pressure)  
PR02 V 02 PC (Vacuum)

2 PNP + Analog Output (1~5V)

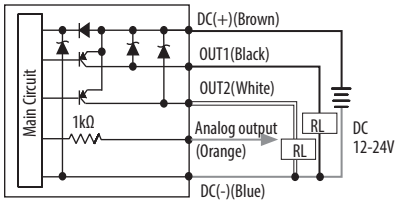

2 PNP + Analog Output (4~20mA)

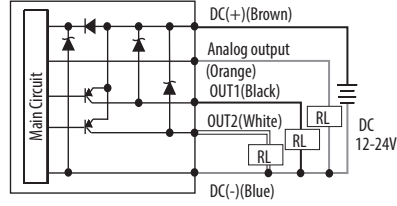

2 PNP + Copy Function

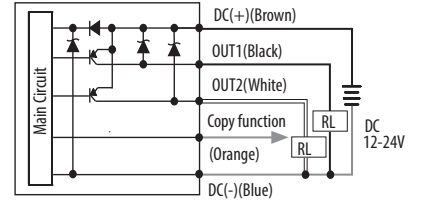

**ACCESSORIES**

MOUNTING BRACKET

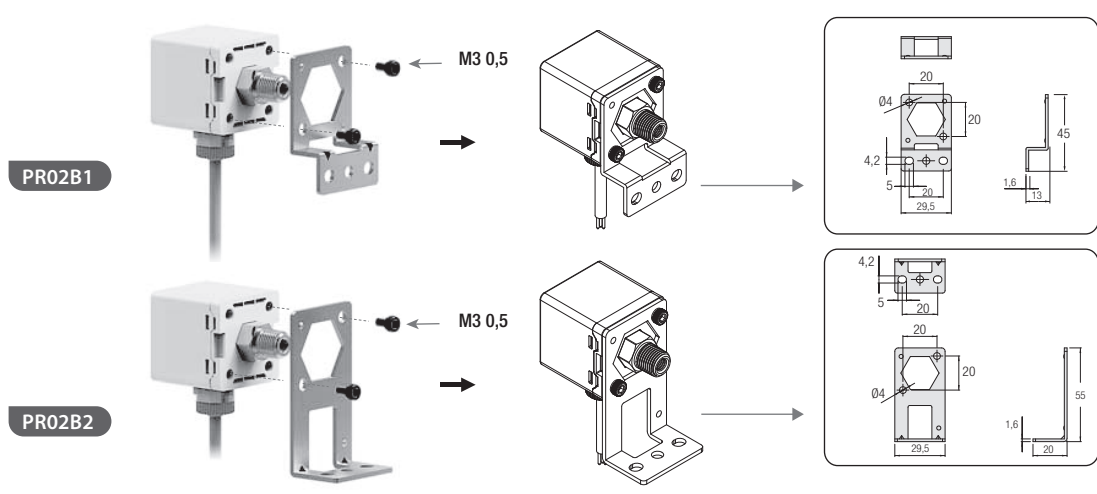

PANEL MOUNT ADAPTER + FRONT PROTECTIVE LID

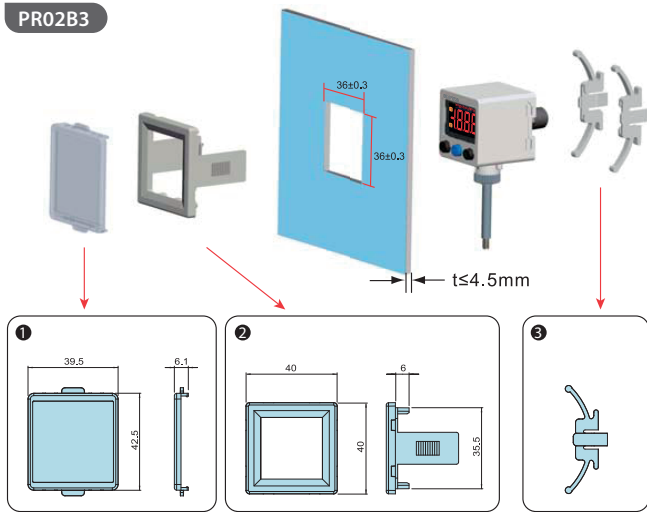

1 Front Protective Lid

2-3 Panel Adapter

IP65 ENCLOSURE

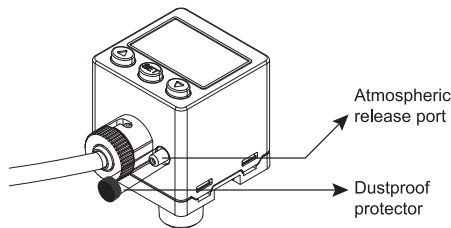

NB: This device must be installed to maintain IP 65 (dust and splash proof) enclosure rating..

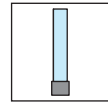

MODEL		PR02 V (Vacuum)	PR02 P (Pressure)	
1.0 MPa ——— 100.0 kPa ——— 0 - - - - - -101.3 kPa ———				
<b>Rated pressure range</b>		0.0 ~ -101.3 kPa 0 ~ -1 Bar		0.000 ~ 1 MPa 0 ~ 10 Bar
<b>Set pressure range</b>		10.0 ~ -101.3 kPa 0,1 ~ -1 Bar		-0.100 ~ 1 MPa -1 ~ 10 Bar
<b>Withstand pressure</b>		300 kPa 3 Bar		1.5 MPa 15 Bar
<b>Fluid</b>		Filtered air, Non-corrosive / Non-flammable gas		
<b>Settaggio unità di pressione</b>	kPa	0.1		-
	MPa	-		0.001
	kgf/cm <sup>2</sup>	0.001		0.01
	bar	0.001		0.01
	psi	0.01		0.1
	inHg	0.1		-
<b>Power supply voltage</b>		12 to 24V DC ±10%, Ripple (P-P) 10% or less		
<b>Current consumption</b>		≤ 40mA (With no load)		
<b>Switch output</b>		PNP: open collector 2 outputs	Max. load current: 125 mA	Max. supply voltage: 24V DC Residual voltage: ≤ 1.5V
<b>Repeatability</b>		±0.2% F.S. ±1 digit		
<b>Hysteresis</b>	One point set mode	(*1) Adjustable		
	Hysteresis mode			
	Window comparator mode			
<b>Response time</b>		≤ 2.5ms (chattering-proof function: 25ms, 100ms, 250ms, 500ms, 1000ms, and 1500ms selectable)		
<b>Output short circuit protection</b>		YES		
<b>7 segment LCD display</b>		3½ digital, 7 segment LCD display (Red/Green/Orange) (Sampling rate: 5 times / sec.)		
<b>Indicator accuracy</b>		±2% F.S. ±1 digit (Ambient temperature: 25 ±3°C)		
<b>Switch ON Indicator</b>		Orange Indicator 1: OUT1 Orange Indicator 2: OUT2		
<b>Analog output (Voltage Output) (*2)</b>		Output Voltag: 1 to 5V ±2.5% F.S. (within rated pressure range) Linearity: ±1% F.S. Output impedance: about 1kΩ		
<b>Analog output (Current Output) (*3)</b>		Output Current: 4 to 20mA ±2.5% F.S. (within rated pressure range) Linearity: ±1% F.S. Max. Load Impedance: 250Ω at power supply of 12V, 600Ω at power supply of 24V Min. Load impedance: ≤ 300 Ω		
<b>Environment</b>	<b>IP enclosure</b>	IP 65		
	<b>Ambient temp.range</b>	Operation: 0 ~ 50°C, Storage:-10 ~ 60°C (No condensation or freezing)		
	<b>Ambient humidity range</b>	Operation/Storage: 35 ~ 85% RH (No condensation)		
	<b>Withstand voltage</b>	1000V AC in 1-min (between case and lead wire)		
	<b>Insulation resistance</b>	50MΩ. (at 500V DC, between case and lead wire)		
	<b>Vibration</b>	Total amplitude 1.5mm or 10G, 10Hz-55Hz-10Hz scan for 1 minute, two hours each direction of X, Y and Z		
	<b>Shock</b>	100m/s <sup>2</sup> (10G), 3 times each in direction of X, Y and Z		
<b>Temperature characteristic</b>		±2.5% F.S. of detected pressure (25°C) at temp. Range of 0~50°C		
<b>Port size</b>		R1/8" - M5		
<b>Lead wire</b>		Oil-resistance cable (0.15 mm <sup>2</sup> )		
<b>Weight</b>		Approx. 86g (with 2 meter lead wire)		

\*1: Hysteresis value is adjustable within 1 ~ 8 digits for one point set mode and window comparator mode.

\*2: If analog voltage output is selected, the analog current cannot be selected at the same time.

\*3: If analog voltage output is selected, the analog voltage cannot be selected at the same time.