

PM/PK/PRM

Cilindri pneumatici
inox

Ø 16 ÷ 125 mm



PM/PK/PRM

Cilindri pneumatici inox Ø 16 ÷ 125 mm

PK

Ø 32 ÷ 125 mm

ISO 15552

I CILINDRI UNIVER serie **PM/PK/PRM** in acciaio inox **AISI 304/316** sono ideati per impieghi in ambienti ad alta incidenza di corrosione, quali l'industria alimentare, chimica, navale e farmaceutica.

Dimensioni a norme internazionali **ISO 6432, 15552 e 21287** per una completa intercambiabilità.



PM

Ø 32 ÷ 63 mm



Caratteristiche costruttive

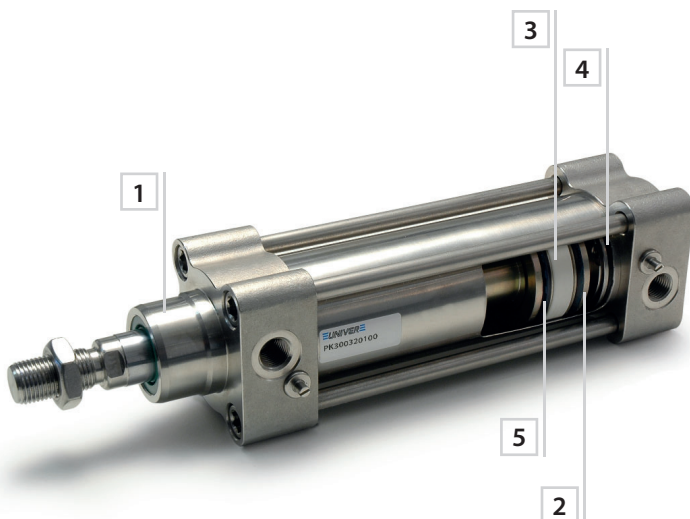

1. Testate in acciaio Inox
2. Pistone metallico
3. Pattino di guida
4. Guarnizioni paracolpi
5. Guarnizioni di tenuta del pistone e ammortizzi

PRM
Ø 20 ÷ 100 mm
ISO 21287

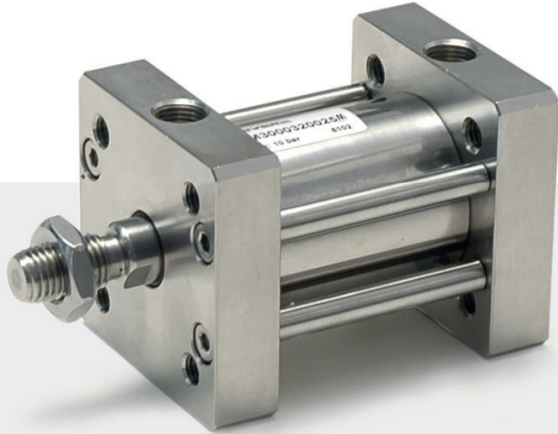

PM
Ø 16 ÷ 25 mm
ISO 6432



CERTIFICAZIONI ATEX
CE, II 2GDc T4
(su richiesta)



GUARNIZIONI STELO PK/PRM
FDA APPROVED (STANDARD)

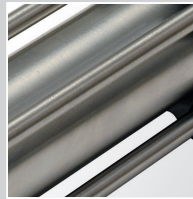

ACCIAIO INOX
AISI 304/316



VITE DI REGOLAZIONE
AMMORTIZZO IN ACCIAIO
INOX SPORGENTE



MONTAGGIO SENSORI IP69K
TRAMITE FASCETTE
E ADATTATORI IN
ACCIAIO INOX



ACCESSORI DI FISSAGGIO
IN ACCIAIO INOX

Settore applicativi



FOOD &
BEVERAGE



WET
AREAS



CHEMICAL



PHARMA



MARINE

PM

Cilindri pneumatici inox ISO 6432 - Ø 16 ÷ 25 mm

- Acciaio inox AISI 304
- Versione doppio effetto
- Versione stelo passante e con ammortizzi regolabili
- Esecuzione con e senza magneti

Disponibile versione ATEX su richiesta

CE Ex II 2GDc T4



CARATTERISTICHE TECNICHE

Temperatura ambiente	0 ÷ 80 °C (-20 °C con aria secca)
Fluido	aria compressa, filtrata, non lubrificata
Pressione di esercizio	1 ÷ 10 bar
Alesaggi	Ø 16 - 20 - 25 mm

CARATTERISTICHE COSTRUTTIVE

Testate	acciaio inox AISI 304
Camicia	acciaio inox AISI 304
Pistone	ottone
Stelo	acciaio inox AISI 304
Guarnizione pistone	poliuretano
Bussola guida stelo	bronzo sinterizzato
Paracolpi	neoprene
Magnete	plastroferrite
Dado	acciaio inox AISI 304
O-Ring	gomma nitrilica (NBR)

CHIAVE DI CODIFICA

P	M	3	0	0	0	1	6	0	0	1	0	M	
1	2	3	4				5			6	7		

1 Serie	2 Tipologia	3 Versione	4 Alesaggio (mm)
PM = Cilindri pneumatici inox ISO 6432 - Ø 16 ÷ 25 mm	3 = Stelo maschio	00 = D.E. Versione standard 01 = D.E. Stelo passante 50 = D.E. Con ammortizzi regolabili (Ø25) 51 = D.E. Stelo passante con ammortizzi regolabili (Ø25)	016 = Ø16 020 = Ø20 025 = Ø25

D.E. = Doppio effetto

5 Corsa (mm)	6 Magnetico	7 Variante ATEX
0010 = 10 0160 = 160 0025 = 25 0200 = 200 0050 = 50 0250 = 250 0080 = 80 0320 = 320 0100 = 100 0400 = 400 0125 = 125 0500 = 500	M = Versione magnetica (standard di serie)	X = ATEX (su richiesta)

Per tipologia e versioni, rivolgersi al nostro Ufficio Commerciale

Su richiesta versioni con guarnizioni per alta temperatura (Max 150°C)

Fissaggi e accessori

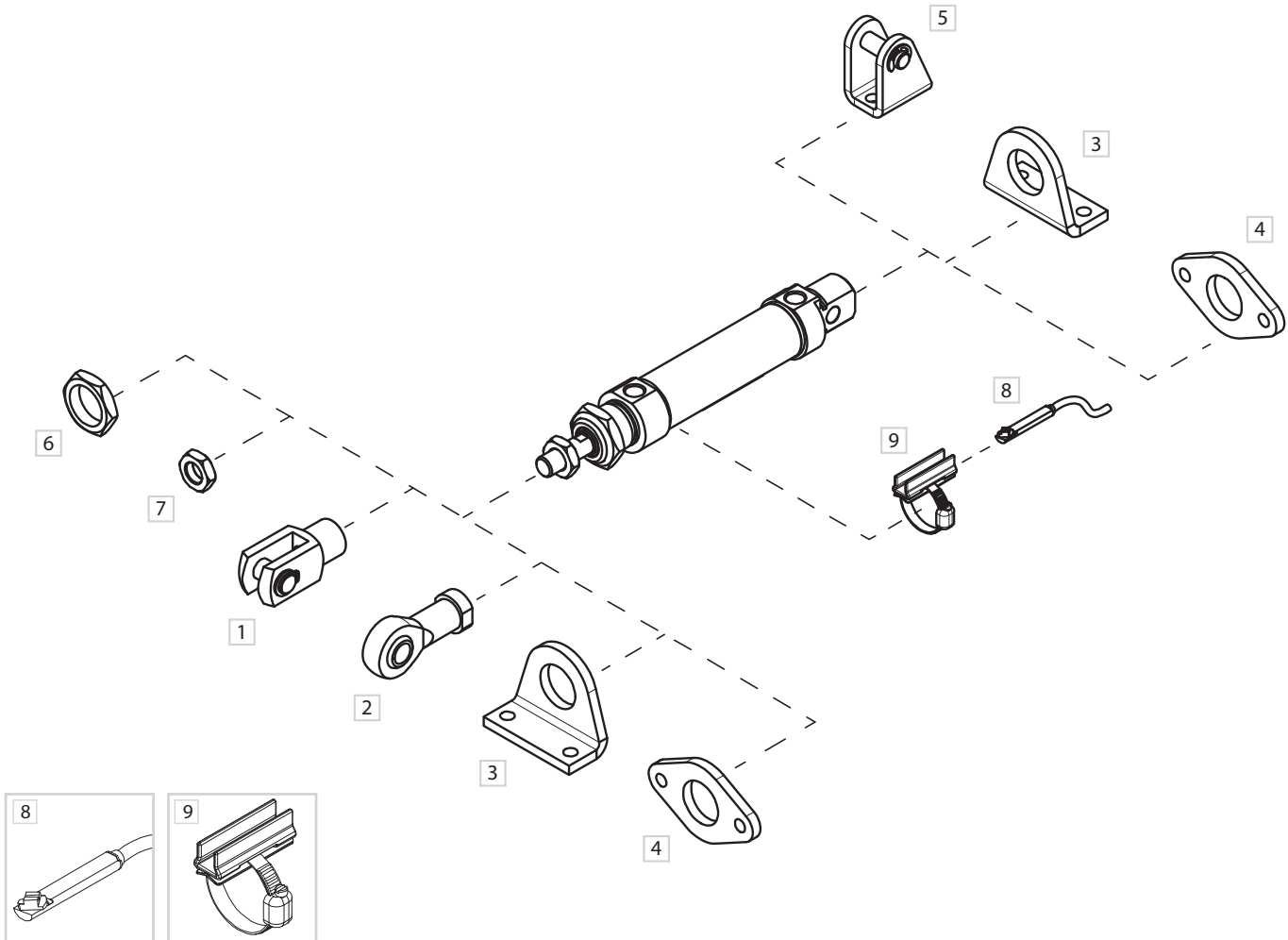

DESCRIZIONE	NOTE	CODICE
1 Forcella femmina con perno	Inox	MF/KF-15__PI
2 Forcella snodata autolubrificata	Inox	MF/KF-17__I
3 Piedino ad angolo (MS3)	Inox	MF-13__I
4 Flangia (MF8)	Inox	MF-12__I
5 Cerniera femmina posteriore	Inox	MF-21__I
6 Dado per testata	Inox	MF-20__I
7 Dado per stelo	Inox	MF-16__I
8 Sensore DF	-	DF-P700L06
9 Fascetta e adattatore DF	Inox	DH-P__DFI

Doppio effetto

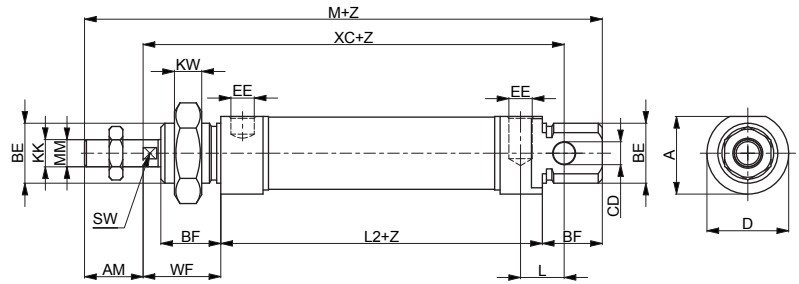
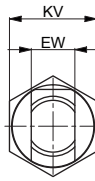

PM300
D.E. Standard



PM350
D.E. Con ammortizzi regolabili

Doppio effetto stelo passante

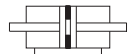

PM301
D.E. Stelo passante

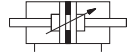

PM351
D.E. Stelo passante
con ammortizzi regolabili

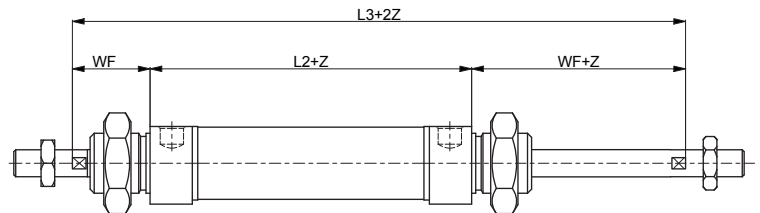

Z= Corsa

Ø	AM	A	BE	BF	CD	D	EE	EW	KK	KV
						H 9			d 13	
16	16	18	M16x1,5	18	6	19	M5x0,8	12	M6x1	22
20	20	25,5	M22x1,5	20	8	27	G1/8	16	M8x1,25	27
25	22	28,5	M22x1,5	22	8	30	G1/8	16	M10x1,25	27
Ø	KW	L	L2	L3	ØMM	M	SW	WF	XC	
								± 1,2	± 1	
16	8	9	53	97	6	109	5	22	82	
20	11	12	67	115	8	131	7	24	95	
25	11	12	68	124	10	140	9	28	104	

Flangia (MF8)

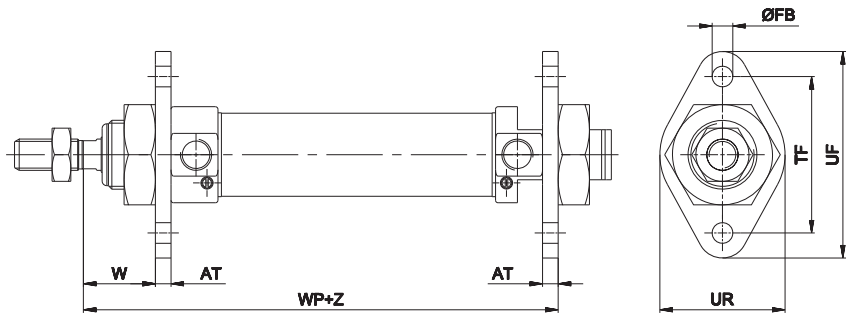
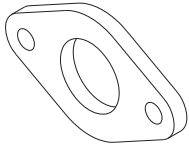

Materiale: Acciaio Inox AISI 304

Z = Corsa

Ø	AT	ØFB	TF	UF	UR	W	WP	Codice
		H13	Js14			± 1,4		
16	4	5,5	40	53	30	18	79	MF-12012I
20	5	6,6	50	66	40	19	96	MF-12020I
25	5	6,6	50	66	40	23	101	

Piedino ad angolo (MS3)

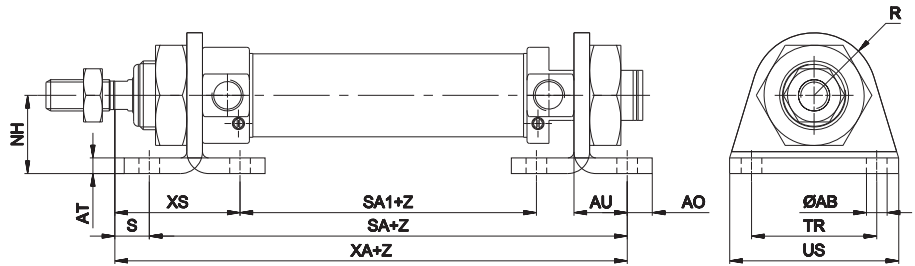
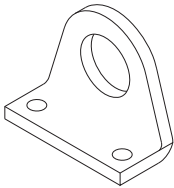

Materiale: Acciaio Inox AISI 304

Z = Corsa

Ø	AB	AO	AT	AU	NH	R	S	SA	SA1	TR	US	XA	XS	Codice
	H13			+0,3 0	±0,3					Js14			±1,4	
16	5,5	6	4	14	20	13	8	81	33	32	42	89	32	MF-13012I
20	6,6	8	5	17	25	20	7	101	43	40	54	108	36	MF-13020I
25	6,6	8	5	17	25	20	11	102	44	40	54	113	40	

Cerniera femmina posteriore

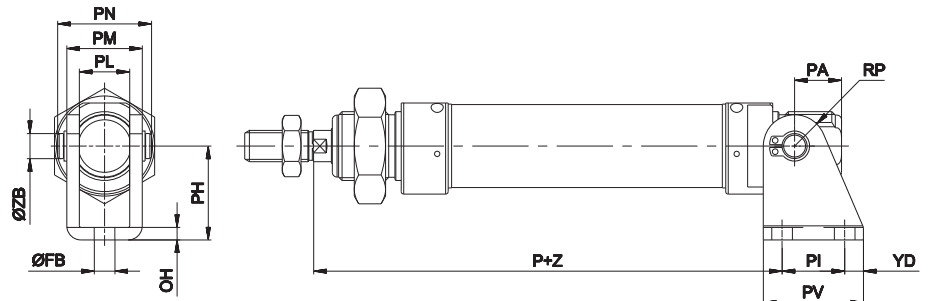
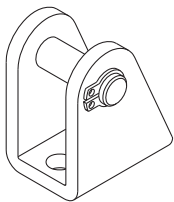

Completa di perno e 2 seeger

Materiale: Acciaio Inox AISI 304

Z = Corsa

Ø	FB	OH	P	PA	PH	PI	PL	PM	PN	PV	RP	YD	ZB	Codice
	H13						E9						f8	
16	5,5	3	80	13	27	15	12,1	18,1	23	25	7	5	6	MF-21012I
20	6,6	4	91	16	30	20	16,1	24,1	30	32	10	6	8	MF-21020I
25	6,6	4	100	16	30	20	16,1	24,1	30	32	10	6	8	

Forcella femmina con perno

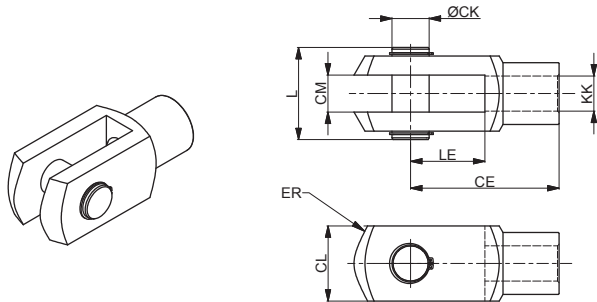

Materiale: Acciaio Inox AISI 303 (Ø16-20) 304 (Ø25)

Ø	CE	CK	CL	CM	ER	KK	L	LE	Codice
16	24	6	12	6	7	M6x1	16	12	MF-15012PI
20	32	8	16	8	10	M8x1,25	22	16	MF-15020PI
25	40	10	20	10	16	M10x1,25	26	20	KF-15032PI

Forcella snodata autolubrificata

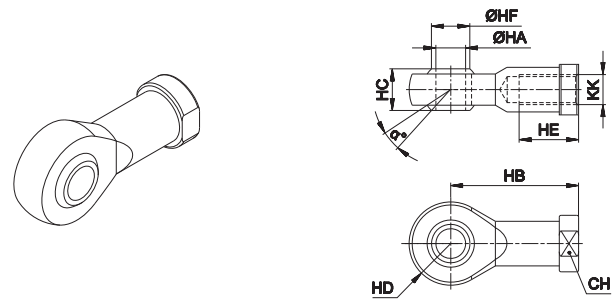

Materiale: Acciaio Inox AISI 303 (Ø16-20) 304 (Ø25)

Ø	α°	CH	KK	HA	HB	HC	HD	HE	HF	Codice
16	13°	11	M6x1	6	30	9	10 ⁰ _{-0,12}	12	9	MF-17012I
20	14°	14	M8x1,25	8	36	12	12	16	10,4	MF-17020I
25	13°	17	M10x1,25	10	43	14	14	20	12,9	KF-17032I

Dado per stelo



Materiale: Acciaio Inox AISI 304

Ø	KK	KV	KW	Codice
16	M6x1	10	4	MF-16012I
20	M8x1,25	13	5	MF-16020I
25	M10x1,25	17	6	KF-16032I

Dado per testata

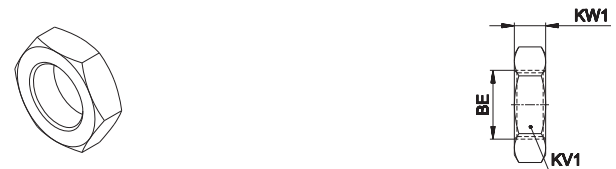

Materiale: Acciaio Inox AISI 303

Ø	BE	KV1	KW1	Codice
16	M16x1,5	24	8	MF-20012I
20	M22x1,5	32	10	MF-20020I

Fascetta per sensori DF

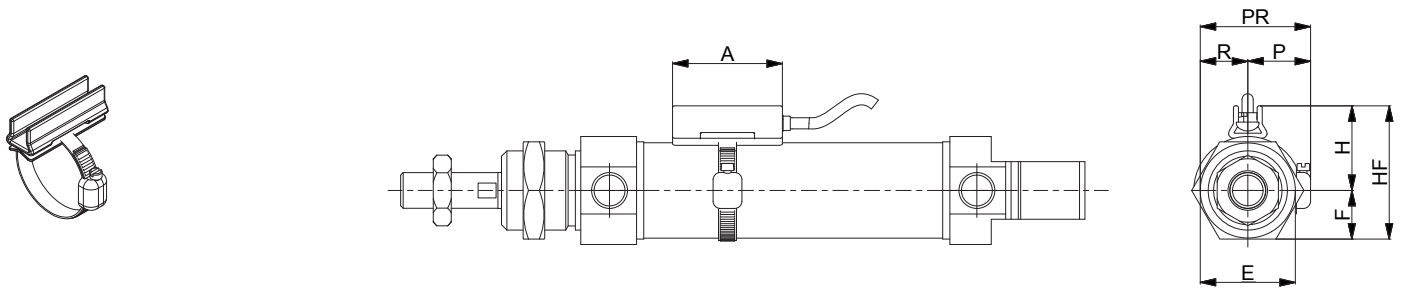

Materiale: Acciaio Inox AISI 303

Ø	A	E	F	H	HF	P	R	PR	Codice
16	34	22	11	18	29	17	11	28	DH-P016020DFI
20	34	24	12	20	32	17	12	29	
25	34	32	16	23	39	19	16	35	DH-P025032DFI

Per sensori serie DF vedi sezione accessori

Sensore DF

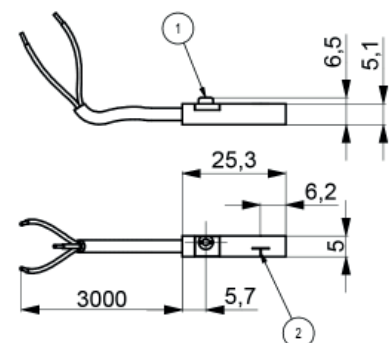

1	2	Codice
eccentrico di fissaggio	superficie attiva	DF-P700L06

PM

Cilindri pneumatici inox - Ø 32 ÷ 63 mm

- Acciaio inox AISI 304
- Versione doppio effetto
- Versione stelo passante
- Esecuzione con e senza magnete



CARATTERISTICHE TECNICHE

Temperatura ambiente	0 ÷ 80 °C (-20 °C con aria secca)
Fluido	aria compressa , filtrata, non lubrificata
Pressione di esercizio	1 ÷ 10 bar
Alesaggi	Ø 32 - 40 - 50 - 63 mm

CARATTERISTICHE COSTRUTTIVE

Testate	acciaio inox AISI 304
Camicia	acciaio inox AISI 304
Pistone	alluminio
Pattino di guida	PBT+PTFE
Stelo	acciaio inox AISI 316
Guarnizione pistone	poliuretano
Bussola guida stelo	bronzo sinterizzato
Paracolpi	neoprene
Magnete	plastroferrite
Dado	acciaio inox AISI 304
O-Ring	gomma nitrilica (NBR)

CHIAVE DI CODIFICA

P	M	3	0	0	0	3	2	0	0	5	0	M
1	2	3	4				5			6		

1 Serie	2 Tipologia	3 Versione	4 Alesaggio (mm)
PM = Cilindri pneumatici inox Ø 32 ÷ 63 mm	3 = Stelo maschio	00 = D.E. Versione standard 01 = D.E. Stelo passante D.E. = Doppio effetto	032 = Ø32 040 = Ø40 050 = Ø50 063 = Ø63

5 Corsa (mm)	6 Magnetico
0010 = 10 0160 = 160 0025 = 25 0200 = 200 0050 = 50 0250 = 250 0080 = 80 0320 = 320 0100 = 100 0400 = 400 0125 = 125 0500 = 500	M = Versione magnetica (standard di serie)

Su richiesta versioni con guarnizioni per alta temperatura (Max 150°C)

Fissaggi e accessori

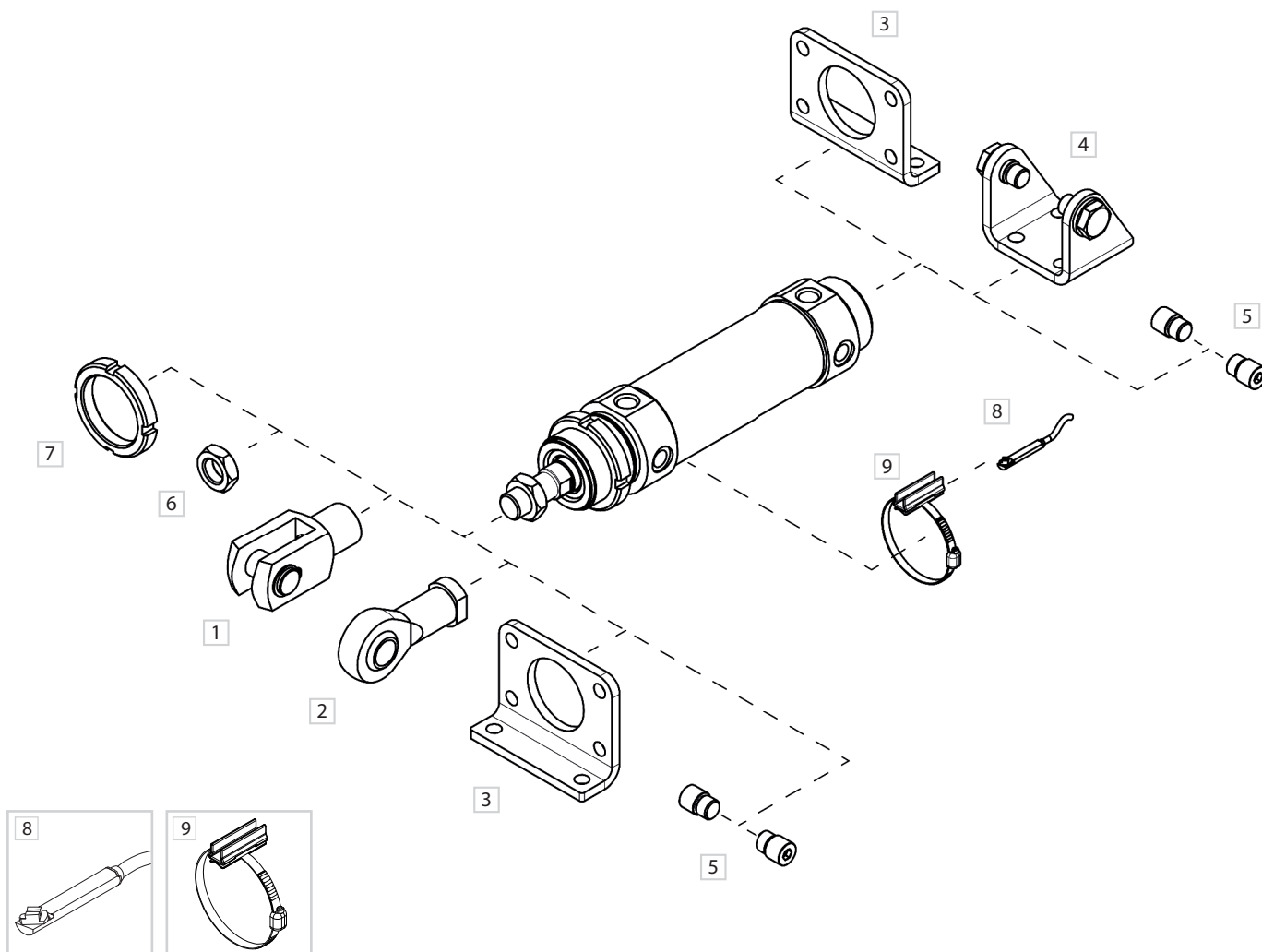

DESCRIZIONE	NOTE	CODICE
1 Forcella femmina con perno	Inox	MF/KF-15 __ _PI
2 Forcella snodata autolubrificata	Inox	MF/KF-17 __ _I
3 Piedino ad angolo/Flangia	Inox	MF-13 __ _I
4 Cerniera femmina con viti	Inox	MF-21 __ _I
5 Perni (coppia)	Inox	MF-18 __ _I
6 Dado per stelo	Inox	MF-16 __ _I
7 Ghiera	Inox	MF-20 __ _I
8 Sensore DF	-	DF-P700L06
9 Fascetta e adattatore DF	Inox	DH-P __ _DFI

Doppio effetto

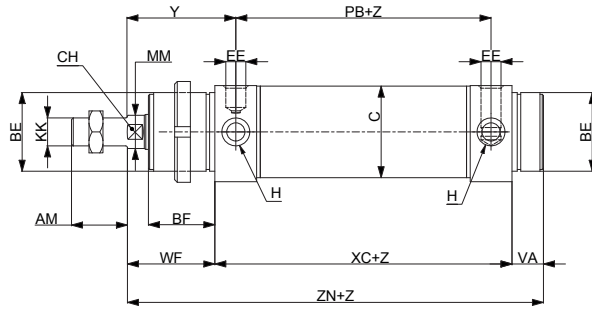
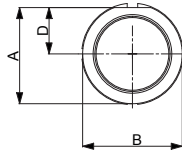

PM300
D.E. Standard

Doppio effetto stelo passante

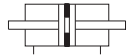

PM301
D.E. Stelo passante

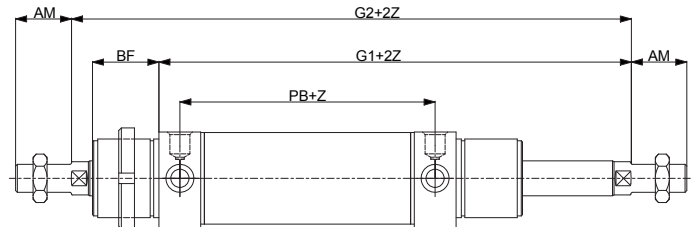

Z= Corsa

Ø	A	AM	ØB	BE	BF	C	CH	D	EE	H
32	36,5	20	38	M30x1,5	30	33,6	10	17,5	1/8 G	M30x1,5
40	44	24	46	M38x1,5	35	41,6	13	21	1/4 G	M38x1,5
50	55	32	57	M45x1,5	38	52,4	17	26,5	1/4 G	M45x1,5
63	67,5	32	70	M45x1,5	38	65,4	17	32,5	3/8 G	M45x1,5

Ø	KK	ØMM	PB	VA	WF	XC	Y	ZN	G1	G2
32	M10x1,25	12	78	14	38	96	47	148	134	172
40	M12x1,25	16	89	16	45	113	57	174	158	203
50	M16x1,5	20	96	18	50	120	62	188	170	220
63	M16x1,5	20	98	18	50	124	63	192	174	224

Perni

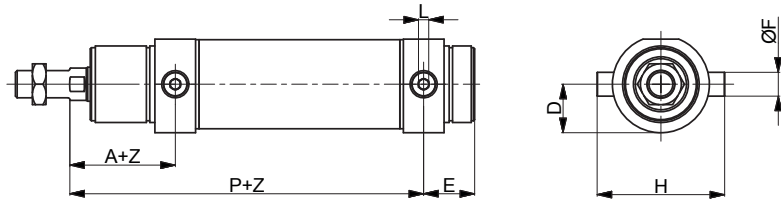

Materiale: Acciaio Inox AISI 304

Z = Corsa

Ø	A	P	E	L	D	H	ØF	Codice
32	47	125	23	5	19	51	10	MF-18032I
40	57	146	28	6	23	61	12	MF-18040I
50	62	158	30	6	28,5	75	14	MF-18050I
63	63	161	31	8	35	92	16	MF-18063I

Piedino ad angolo/Flangia

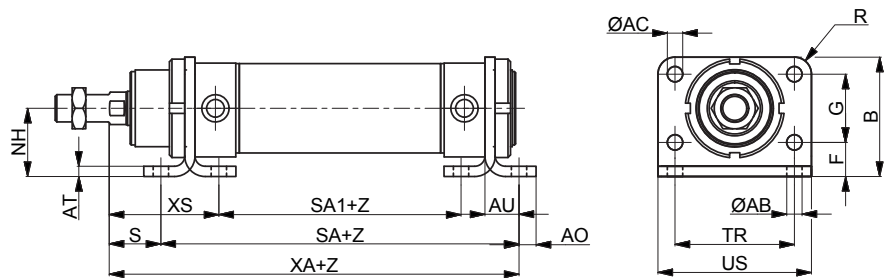
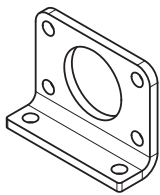

Materiale: Acciaio Inox AISI 304

Z = Corsa

Ø	NH	AT	XS	S	SA	SA1	XA	AU	AO	ØAC	R	US	TR	ØAB	F	G	B	Codice
32	28	4	52	24	124	68	148	14	7	7	7	66	52	7	14	28	49	MF-13032I
40	33	5	65	25	153	73	178	20	10	9	10	80	60	9	18	30	58	MF-13040I
50	40	6	70	30	160	80	190	20	10	9	10	90	70	9	20	40	70	MF-13050I
63	45	6	70	30	164	84	194	20	10	9	10	96	76	9	20	50	80	MF-13063I

Cerniera femmina con viti

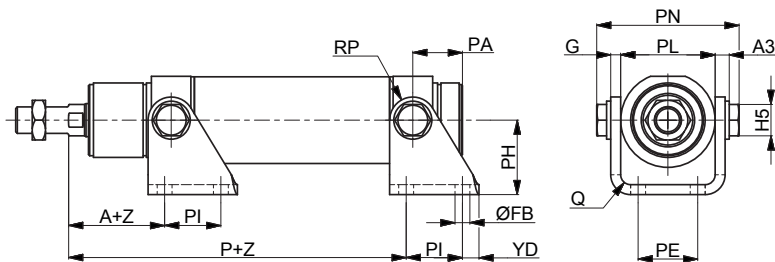
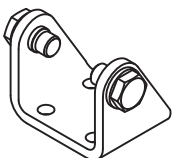

Completa di perno e 2 seeger

Materiale: Acciaio Inox AISI 304

Z = Corsa

Ø	A	P	PI	ØFB	YD	PH	RP	PA	G	PN	PL	A3	H5	PE	Q	Codice
32	45	120	24	7	8	35	12	20	4	54,1	38,1	6	13	20	4	MF-21032I
40	55	141	30	9	10	40	13	27	5	65,1	46,1	7	17	28	5	MF-21040I
50	59	152	34	9	10	45	14	30	6	80,1	57,1	8,5	19	36	6	MF-21050I
63	60	155	35	9	15	50	16	34	6	93,1	70,1	8,5	19	42	6	MF-21063I

Forcella femmina con perno

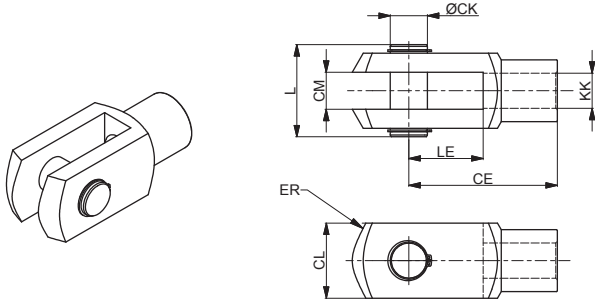

Materiale: Acciaio Inox AISI 304

Ø	CE	CK	CL	CM	ER	KK	L	LE	Codice
32	40	10	20	10	16	M10x1,25	26	20	KF-15032PI
40	48	12	24	12	19	M12x1,25	32	24	KF-15040PI
50	64	16	32	16	25	M16x1,5	40	32	KF-15050PI
63									

Forcella snodata autolubrificata

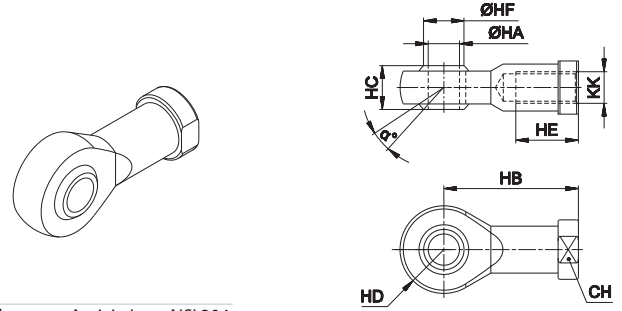

Materiale: Acciaio Inox AISI 304

Ø	α°	CH	KK	HA	HB	HC	HD	HE	HF	Codice
32	13	17	M10x1,25	10	43	14	14	20	12,9	KF-17032I
40	13	19	M12x1,25	12	50	16	16	22	15,4	KF-17040I
50	15	22	M16x1,5	16	64	21	21	28	19,3	KF-17050I
63										

Ghiera per testata

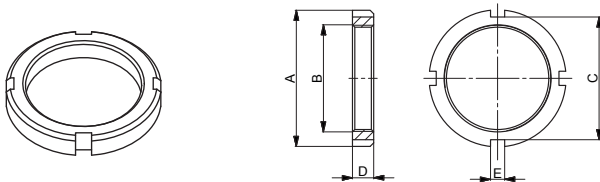

Materiale: Acciaio Inox AISI 304

Ø	A	B	C	D	E	Codice
40	50	M38x1,5	46	8	5	MF-20040I
50	58	M45x1,5	52	9	6	MF-20050I
63	58	M45x1,5	52	9	6	MF-20063I

Dado per stelo



Materiale: Acciaio Inox AISI 304

Ø	KK	KV	KW	Codice
40	M12x1,25	19	7	KF-16040I
50	M16x1,5	24	8	KF-16050I
63				

Fascetta per sensori DF

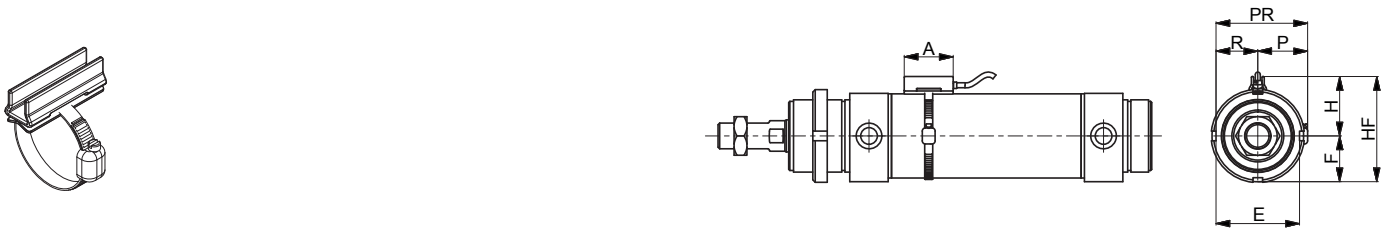

Materiale: Acciaio Inox AISI 303

Ø	A	E	F	H	HF	P	R	PR	Codice
40	34	41,5	20,75	53	94,5	47	41,5	88,5	DH-P040DFI
50	34	51,5	25,75	63	114,5	57	51,5	108,5	DH-P050DFI
63	34	64,5	32,25	76	140,5	70	64,5	134,5	DH-P063DFI

Per sensori serie DF vedi sezione accessori

Sensore DF



1	2	Codice
eccentrico di fissaggio	superficie attiva	DF-P700L06

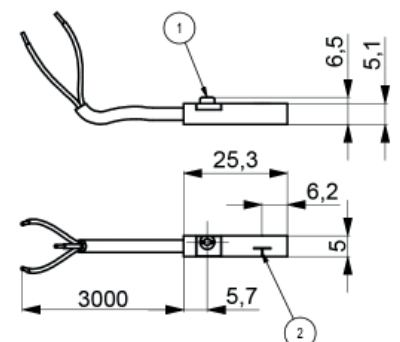

PK

Cilindri pneumatici inox ISO 15552 - Ø 32 ÷ 125 mm

- Acciaio Inox AISI 316
- Versione doppio effetto
- Versione stelo passante
- Guarnizione stelo certificata FDA
- Esecuzione con e senza magneti

Disponibile versione ATEX su richiesta

CE II 2GDc T4



CARATTERISTICHE TECNICHE

Temperatura ambiente	0 ÷ 80 °C (-20 °C con aria secca) 0 ÷ 150 °C (con guarnizioni per alte temperature)
Fluido	aria compressa, filtrata, non lubrificata
Pressione di esercizio	1 ÷ 10 bar
Alesaggi	Ø 32 - 40 - 50 - 63 - 80 - 100 - 125 mm
Ammortizzi	regolabili su entrambi i lati

CARATTERISTICHE COSTRUTTIVE

Testate	acciaio inox AISI 316
Camicia	acciaio inox AISI 316
Pistone	pressofuso di alluminio
Pattino di guida	PBT+PTFE
Stelo	acciaio inox AISI 316
Guarnizione pistone	poliuretano
Bussola guida stelo	bronzo sinterizzato
Magnete	plastroferrite
O-Ring	gomma nitrilica (NBR)
Tiranti	acciaio inox AISI 316

CHIAVE DI CODIFICA

P	K	3	0	0	0	3	2	0	0	2	5	M	
1	2	3	4			5			6	7			

1 Serie	2 Tipologia	3 Versione	4 Alesaggio (mm)
PK = Cilindri pneumatici inox ISO 15552 Ø 32 ÷ 125 mm	3 = Stelo maschio	00 = D.E. Versione standard 01 = D.E. Stelo passante D.E. = Doppio effetto	032 = Ø32 080 = Ø80 040 = Ø40 100 = Ø100 050 = Ø50 125 = Ø125 063 = Ø63
5 Corsa (mm)	6 Magnetico	7 Variante ATEX	
0025 = 25 0150 = 150 0320 = 320 0600 = 600 0850 = 850 0050 = 50 0160 = 160 0400 = 400 0650 = 650 0900 = 900 0080 = 80 0200 = 200 0450 = 450 0700 = 700 0950 = 950 0100 = 100 0250 = 250 0500 = 500 0750 = 750 1000 = 1000 0125 = 125 0300 = 300 0550 = 550 0800 = 800	M = Versione magnetica (standard di serie)	X = ATEX (su richiesta) Per tipologia e versioni, rivolgersi al nostro Ufficio Commerciale	

Su richiesta versioni con guarnizioni per alta temperatura (Max 150°C)

Fissaggi e accessori

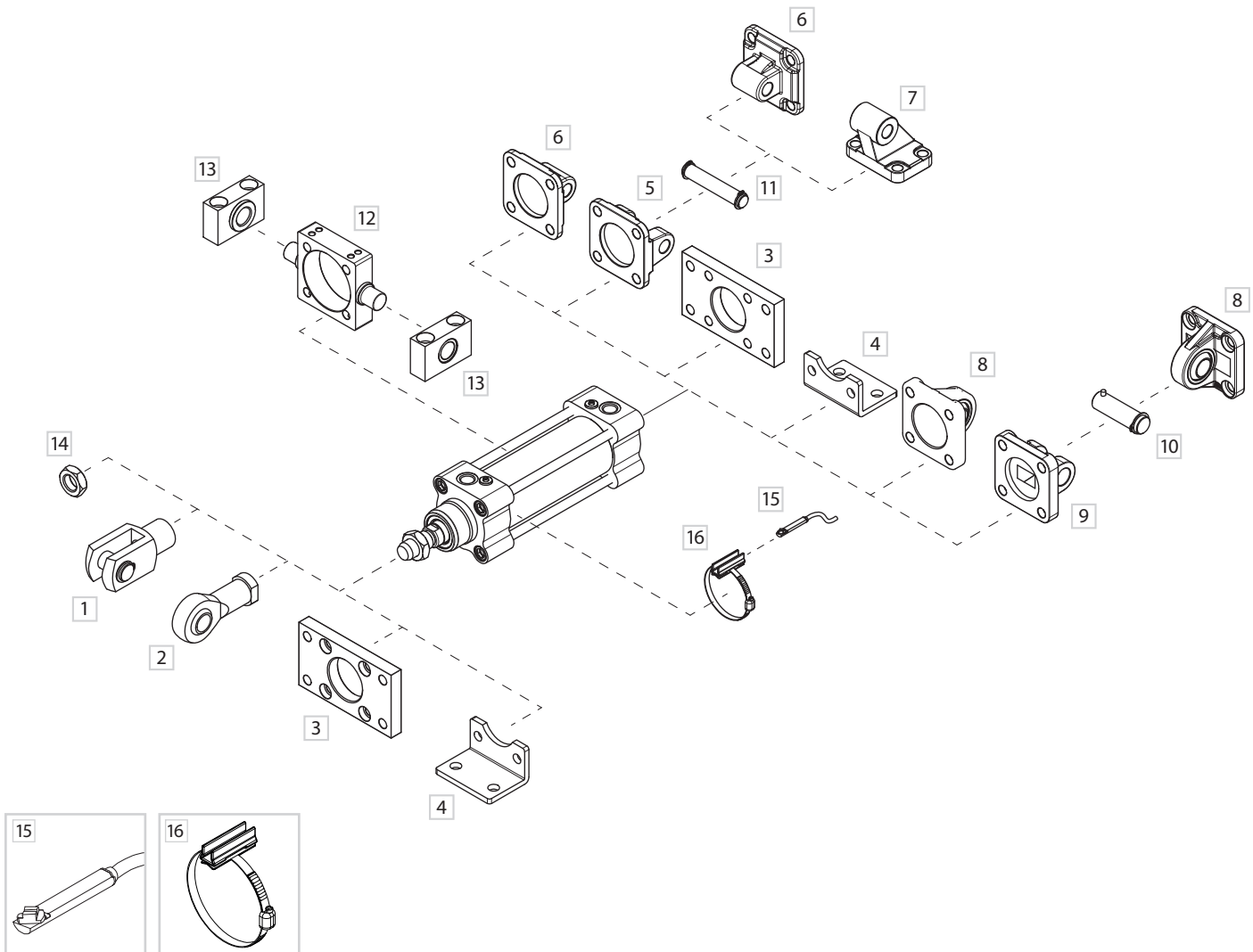

DESCRIZIONE	NOTE	CODICE
1 Forcella femmina con perno	Inox	KF-15 __ _PI
2 Forcella snodata autolubrificata	Inox	KF-17 __ _I
3 Flangia anteriore-posteriore (ISO MF1-MF2)	Inox	KF-12 __ _I
4 Piedino ad angolo (ISO MS1)	Inox	KF-13 __ _I
5 Cerniera femmina (ISO MP2)	Inox	KF-10 __ _AI
6 Cerniera posteriore maschio (ISO MP4)	Inox	KF-11 __ _I
7 Contro-cerniera 90° (CETOP RP107P)	Inox	KF-19 __ _CTAI
8 Cerniera posteriore maschio snodata (ISO MP6)	Inox	KF-11 __ _SI
9 Cerniera femmina stretta con perno (DIN648K)	Inox	KF-10 __ _ASI/
10 Perno cerniera stretta (DIN648K)	Inox	KF-18S I
11 Perno cerniera femmina (ISO MS1)	Inox	KF-18 _I
12 Cerniera intermedia per tiranti	Inox	KF-14 __ _TI
13 Supporto per cerniera	Inox	KF-41 __ _I
14 Dado stelo	Inox	KF-16 __ _I
15 Sensore DF	-	DF-P700L06
16 Fascetta e adattatore DF	Inox	DH-P __ _DFI

Doppio effetto

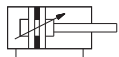
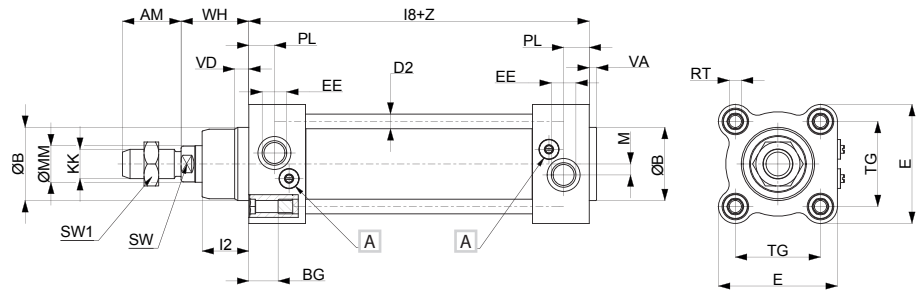

PK300
D.E. Standard

Doppio effetto stelo passante



PK301
D.E. Stelo passante

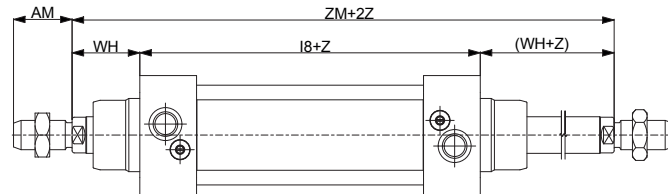

Z= Corsa

Ø	AM	ØB	BG	E	KK	I2	I8	PL	RT	SW	TG	VA	VD	WH	ØMM	EE	M	SW1	D2	ZM
32	22	30	16	48	M10x1,25	18	94 ±0,4	13	M6	10	32,5 ±0,5	4	5	26	12	G1/8	5,3	17	6	146
40	24	35	16	52	M12x1,25	22	105 ±0,7	14	M6	13	38 ±0,5	4	5	30	16	G1/4	5	19	6	165
50	32	40	16	65	M16x1,5	25,5	106 ±0,7	14	M8	17	46,5 ±0,6	4	6	37	20	G1/4	6	24	8	180
63	32	45	16	75	M16x1,5	26	121 ±0,8	16	M8	17	56,5 ±0,7	4	6	37	20	G3/8	6,5	24	8	195
80	40	45	18	95	M20x1,5	32	128 ±0,8	16	M10	22	72 ±0,7	4	7	46	25	G3/8	8	30	10	220
100	40	55	18	115	M20x1,5	38	138 ±1	18	M10	22	89 ±0,7	4	7	51	25	G1/2	7	30	10	240
125	54	60	20	140	M27x2	46	160 ±1	18	M12	27	110 ±1,1	6	10	65	32	G1/2	7	41	12	290

A Vite di regolazione ammortizzo pneumatico

Cerniera femmina (ISO MP2) con perno

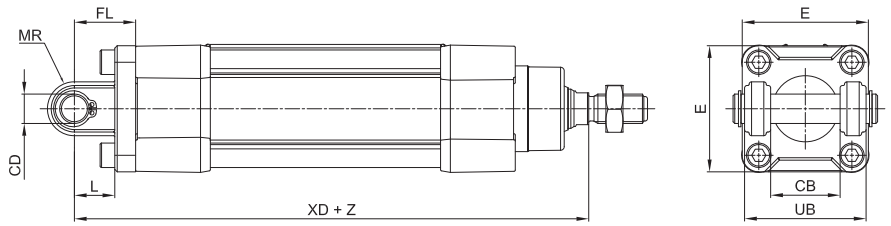
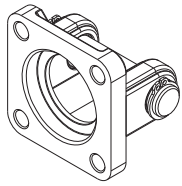

Materiale: Acciaio Inox AISI 304

Z = Corsa

Ø	CB	CD	E	FL	L	MR	UB	XD		Codice
	H14	H9		± 0,2	min	Max	h14			
32	26	10	48	22	12	11	45	142	±1,25	KF-10032AI
40	28	12	54	25	15	13	52	160	±1,25	KF-10040AI
50	32	12	65	27	15	13	60	170	±1,25	KF-10050AI
63	40	16	75	32	20	17	70	190	±1,6	KF-10063AI
80	50	16	95	36	20	17	90	210	±1,6	KF-10080AI
100	60	20	115	41	25	21	110	230	±1,6	KF-10100AI
125	70	25	140	50	30	26	130	275	±2	KF-10125AI

Cerniera femmina stretta con perno (DIN648K)

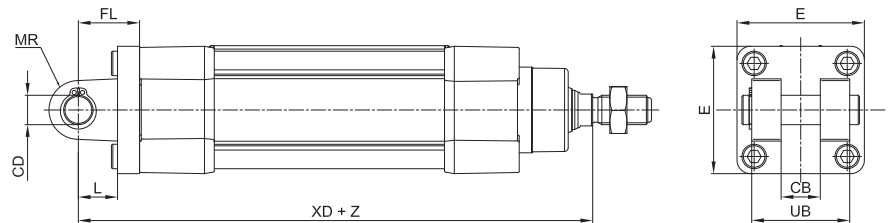
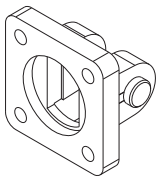

Materiale: Acciaio Inox AISI 316

Z = Corsa

Ø	CB	CD	E	FL	L	MR	UB	XD		Codice
	H14	H9		± 0,2	min	Max	h14			
32	14	10	45	22	10	10	34	142	±1,25	KF-10032ASI
40	16	12	52	25	16	12	40	160	±1,25	KF-10040ASI
50	21	16	65	27	16	14	45	170	±1,5	KF-10050ASI
63	21	16	75	32	21	18	51	190	±1,6	KF-10063ASI
80	25	20	95	36	22	20	65	210	±1,6	KF-10080ASI
100	25	20	115	41	27	22	75	230	±1,6	KF-10100ASI
125	37	30	140	50	30	25	97	275	±2	KF-10125ASI

Perno per cerniera femmina

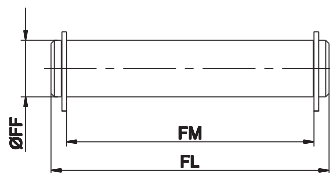

Perno per cerniera femmina stretta

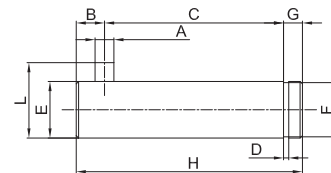

Completo di 2 seeger di arresto

Materiale: Acciaio Inox AISI 304

Ø	FF	FL	FM	Codice
32	f8			
32	10	53	46	KF-18032I
40	12	61,3	53	KF-18040I
50	12	69	61	KF-18050I
63	16	80,5	71	KF-18063I
80	16	100,5	91	KF-18080I
100	20	122,5	111	KF-18100I
125	25	140	131	KF-18125I

Completo di 2 seeger di arresto

Materiale: Acciaio Inox AISI 316

Ø	A	C	D	E	F	G	H	L	B	Codice
	H12	$\pm 0,5$ $+0,3$	h13	f7	h11			0 $-0,5$		
32	3	32,5	1,1	10	9,6	4	41	14	4,5	KF-18032SI
40	4	38	1,1	12	11,5	4	48	16	6	KF-18040SI
50	4	43	1,1	16	15,2	5	54	20	6	KF-18050SI
63	4	49	1,1	16	15,2	5	60	20	6	KF-18063SI
80	4	63	1,3	20	19	6	75	24	6	KF-18080SI
100	4	73	1,3	20	19	6	85	24	6	KF-18100SI
125	6	94	1,6	30	28,6	7	110	36	9	KF-18125SI

Cerniera posteriore maschio (ISO MP4)

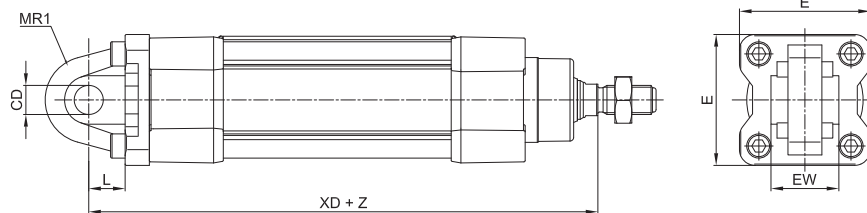
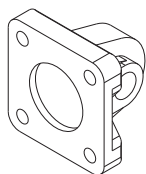

Materiale: Acciaio Inox AISI 304

Z = Corsa

Ø	CD	E	EW		L	MR1	XD	Codice
	H9				min			
32	10	48	26	-0,2 / -0,6	12	15*	142 ±1,25	KF-11032I
40	12	54	28	-0,2 / -0,6	15	18*	160 ±1,25	KF-11040I
50	12	65	32	-0,2 / -0,6	15	20*	170 ±1,25	KF-11050I
63	16	75	40	-0,2 / -0,6	20	23*	190 ±1,6	KF-11063I
80	16	95	50	-0,2 / -0,6	20	27*	210 ±1,6	KF-11080I
100	20	115	60	-0,2 / -0,6	25	29,5*	230 ±1,6	KF-11100I
125	25	140	70	-0,5 / -1,2	30	26	275 ±2	KF-11125I

* = Quote non a norma

Cerniera posteriore maschio snodata (ISO MP6)

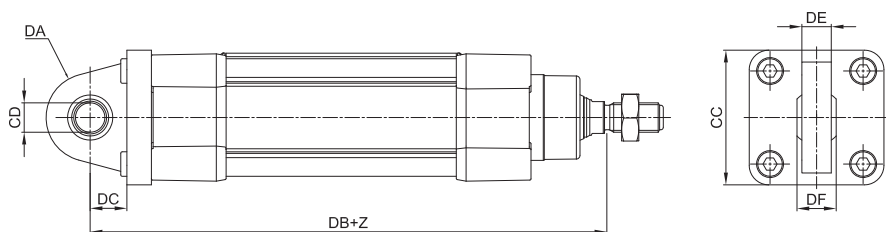
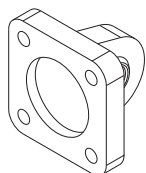

Materiale: Acciaio Inox AISI 316

Z = Corsa

Ø	CC	CD	DA	DB	DC	DE	DF	Codice
		H9						
32	48	10	15	142	14	10,5	14	KF-11032SI
40	54	12	18	160	16,5	12	16	KF-11040SI
50	65	12	20	170	17,5	12	16	KF-11050SI
63	75	16	21	190	21,5	15	21	KF-11063SI
80	95	16	27	210	24	15	21	KF-11080SI
100	115	20	29,5	230	28	18	25	KF-11100SI
125	140	30	40	275	30	25	37	KF-11125SI

Flangia anteriore/posteriore (ISO MF1-MF2)

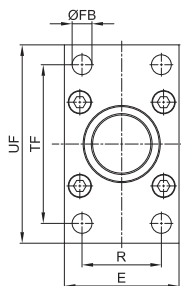
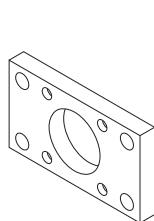

> Montaggio posteriore

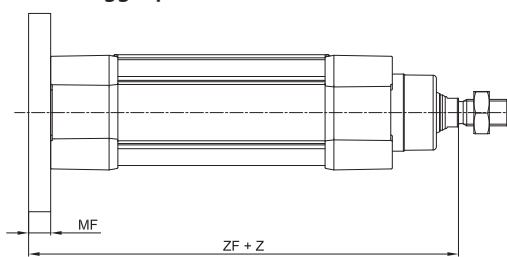

> Montaggio anteriore

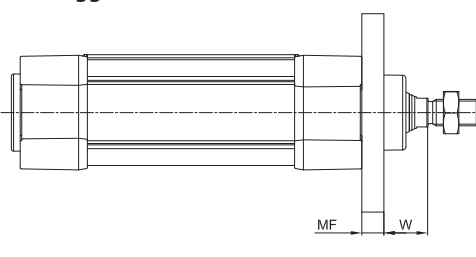

Materiale: Acciaio Inox AISI 304

Z = Corsa

Ø	E	FB	MF	R	TF	UF	W	ZF	Codice
		H13	±0,2	JS14	JS14	Max			
32	45	7	10	32	64	80	16 ±1,6	130 ±1,25	KF-12032I
40	52	9	10	36	72	90	20 ±1,6	145 ±1,25	KF-12040I
50	65	9	12	45	90	110	25 ±2	155 ±1,25	KF-12050I
63	75	9	12	50	100	120	25 ±2	170 ±1,6	KF-12063I
80	95	12	16	63	126	150	30 ±2	190 ±1,6	KF-12080I
100	115	14	16	75	150	170	35 ±2	205 ±1,6	KF-12100I
125	140	16	20	90	180	205	45 ±2,5	245 ±2	KF-12125I

Piedino ad angolo (ISO MS1)

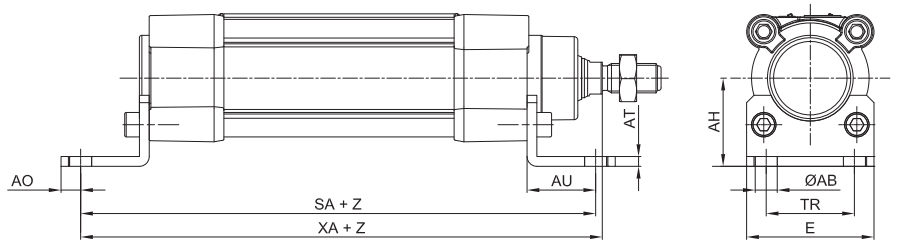
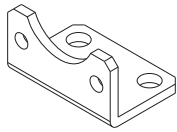

Materiale: Acciaio Inox AISI 304

Z = Corsa

Ø	ØAB	AH	AO	AT	AU	E	SA	TR	XA	Codice		
	H13	JS15									±0,2	JS14
32	7	32	6	4	24	45	142	±1,25	32	144	±1,25	KF-13032I
40	9	36	8	4	28	52	161	±1,25	36	163	±1,25	KF-13040I
50	9	45	10	5	32	64	170	±1,25	45	175	±1,25	KF-13050I
63	9	50	12	5	32	74	185	±1,6	50	190	±1,6	KF-13063I
80	12	63	15	6	41	94	210	±1,6	63	215	±1,6	KF-13080I
100	14	71	20	6	41	114	220	±1,6	75	230	±1,6	KF-13100I
125	16	90	15	8	45	140	250	±2	90	270	±2	KF-13125I

Cerniera intermedia per tiranti

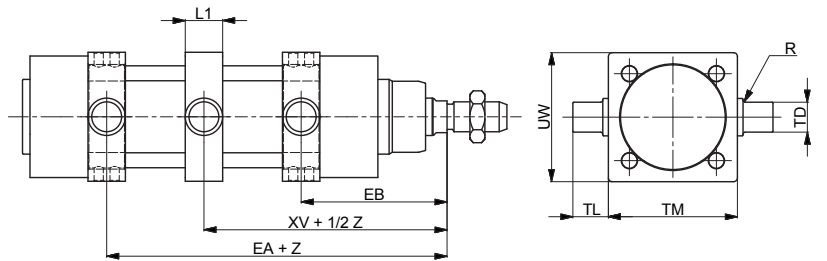
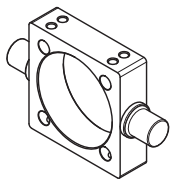

Materiale: Acciaio Inox AISI 304

Ø	EA	EB	L1	R	TD	TL	TM	UW	XV	Codice	
	Max	min									e9
32	82	64	22	0,5	12	12	50	65	73	±2	KF-14032TI
40	93	72	22	0,5	16	16	63	75	82,5	±2	KF-14040TI
50	101	79	22	0,5	16	16	75	95	90	±2	KF-14050TI
63	107	88	27,5	1	20	20	90	105	97,5	±2	KF-14063TI
80	123	97	27,5	1,5	20	20	110	130	110	±2	KF-14080TI
100	131	109	33	1	25	25	132	145	120	±2	KF-14100TI
125	164	126	33	1	25	25	160	175	145	±2,5	KF-14125TI

Contro-cerniera a 90° (CETOP RP107P)

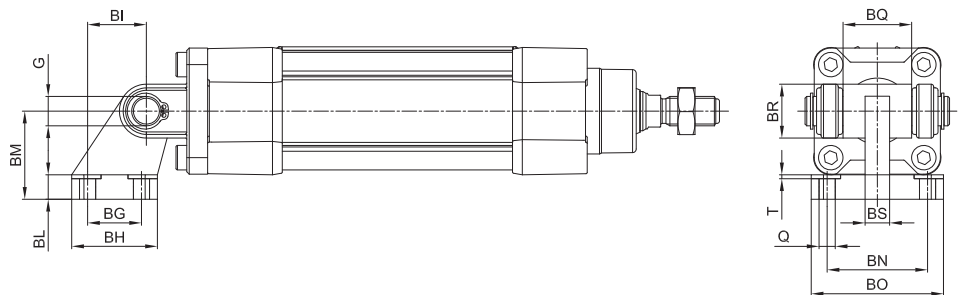
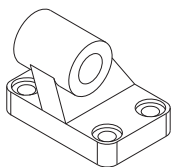

Materiale: Acciaio Inox AISI 304

Ø	Q	BG	BH	BI	BL	BM	BN	BO	BS	BR	T	G	Codice
	H13	JS14	Max	JS14		JS15	JS14	Max	Max	Max	Max	H9	
32	6,6	18	31	21	8	32	38	51	10	20	1,6	10	KF-19032CTAI
40	6,6	22	35	24	10	36	41	54	15	22	1,6	12	KF-19040CTAI
50	9	30	45	33	12	45	50	65	16	26	1,6	12	KF-19050CTAI
63	9	35	50	37	14	50	52	67	16	30	1,6	16	KF-19063CTAI
80	11	40	60	47	14	63	66	86	20	30	2,5	16	KF-19080CTAI
100	11	50	70	55	17	71	76	96	20	38	2,5	20	KF-19100CTAI
125	14	60	90	70	20	90	94	124	30	45	3,2	25	KF-19125CTAI

Supporto per cerniera

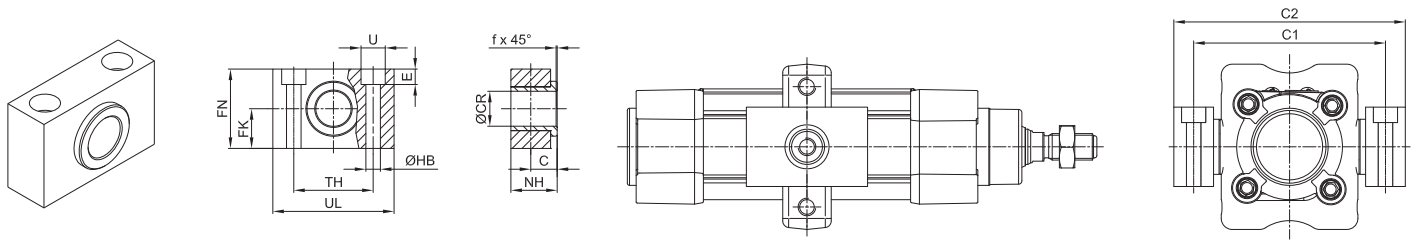

Materiale: Acciaio Inox AISI 304

Ø	C	ØCR	FK	FN	ØHB	NH	TH	UL	ØU	E	f	C1	C2	Codice
	H9	f7	±0,1				±0,1			±0,5				
32	10,5	12	15	30	6,6	18	32	46	11	7	1	71	86	KF-41032I
40	12	16	18	36	9	21	36	55	15	9	1,6	87	105	KF-41040050I
50	12	16	18	36	9	21	36	55	15	9	1,6	99	117	KF-41040050I
63	13	20	20	40	11	23	42	65	18	11	1,6	116	136	KF-41063080I
80	13	20	20	40	11	23	42	65	18	11	1,6	136	156	KF-41063080I
100	16	25	25	50	14	28,5	50	75	20	13	2	164	189	KF-41100125I
125	16	25	25	50	14	28,5	50	75	20	13	2	192	217	KF-41100125I

Forcella femmina con perno

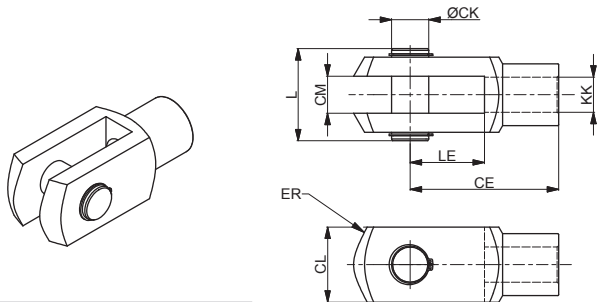

Materiale: Acciaio Inox AISI 304

Ø	CE	CK	CL	CM	ER	KK	L	LE	Codice
	B12								
32	40	10	20	10	16	M10x1,25	26	20	KF-15032PI
40	48	12	24	12	19	M12x1,25	32	24	KF-15040PI
50 - 63	64	16	32	16	25	M16x1,5	40	32	KF-15050PI
80 - 100	80	20	40	20	32	M20x1,5	50	40	KF-15080PI
125	110	30	55	30	45	M27x2	65	54	KF-15125PI

Forcella snodata autolubrificata

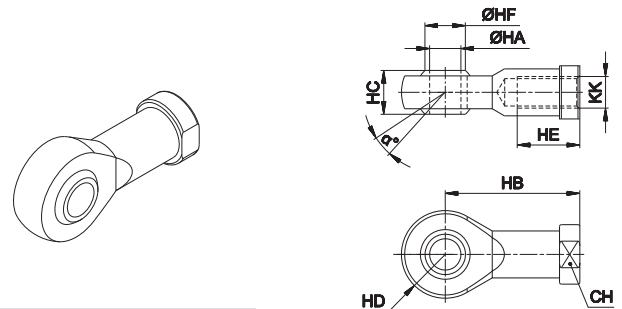

Materiale: Acciaio Inox AISI 304

Ø	α°	CH	KK	HA	HB	HC	HD	HE	HF	Codice
		H7	H7	H7	0 -0,12					
32	13	17	M10x1,25	10	43	14	14	20	12,9	KF-17032I
40	13	19	M12x1,25	12	50	16	16	22	15,4	KF-17040I
50 - 63	15	22	M16x1,5	16	64	21	21	28	19,3	KF-17050I
80 - 100	14	30	M20 x 1,5	20	77	25	25	33	24,3	KF-17080I
125	17	41	M27x2	30	110	37	35	51	34,8	KF-17125I

Forcella adatta per stelo a norma ISO 8140 completa di perno

Dado per stelo

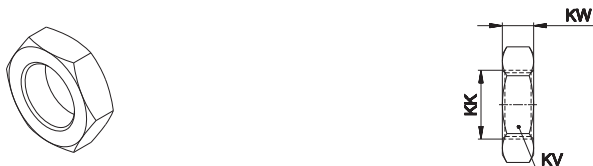

Materiale: Acciaio Inox AISI 304

Ø	KK	KV	KW	Codice
32	M10x1,25	17	6	KF-16032I
40	M12x1,25	19	7	KF-16040I
50 - 63	M16x1,5	24	8	KF-16050I
80 - 100	M20x1,5	30	9	KF-16080I
125	M27x2	41	12	KF-16125I

Fascetta per sensori DF

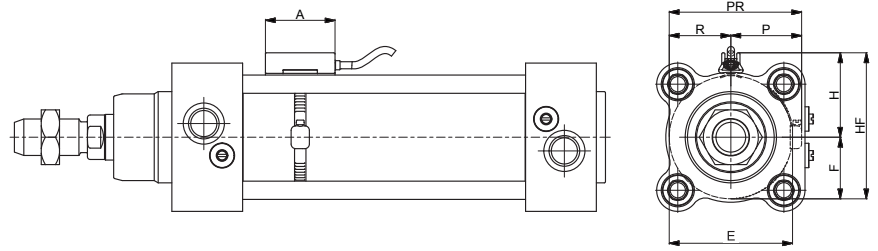
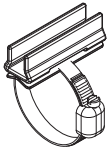

Materiale: Acciaio Inox AISI 303

Ø	A	E	H	F	HF	P	R	PR	Codice
32	34	33,5	45	16,75	78,5	39	33,5	72,5	DH-P025032DFI
40	34	41,5	53	20,75	94,5	47	41,5	88,5	DH-P040DFI
50	34	51,5	63	25,75	114,5	57	51,5	108,5	DH-P050DFI
63	34	64,5	76	32,25	140,5	70	64,5	134,5	DH-P063DFI
80	34	81,5	93	40,75	174,5	87	81,5	168,5	DH-P080DFI
100	34	101,5	113	50,75	214,5	107	101,5	208,5	DH-P100DFI
125	34	126,5	138	63,25	264,5	132	126,5	258,5	DH-P125DFI

Per sensori serie DF vedi sezione accessori

Sensore DF

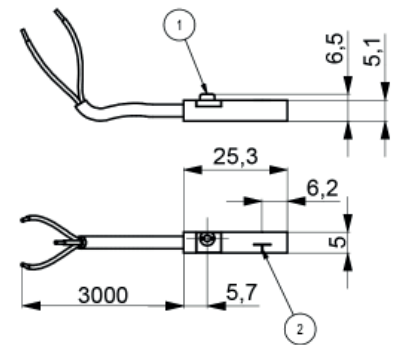
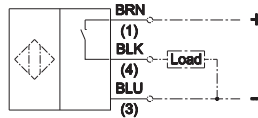
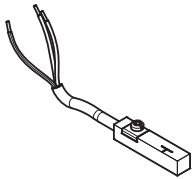

1	2	Codice
eccentrico di fissaggio	superficie attiva	DF-P700L06

PRM

Cilindri pneumatici inox compatti ISO 21287 - Ø 20 ÷ 100 mm

- Acciaio Inox AISI 316
- Versioni doppio effetto e semplice effetto
- Versione stelo passante
- Guarnizione stelo certificata FDA

Disponibile versione ATEX su richiesta

CE II 2GDc T4

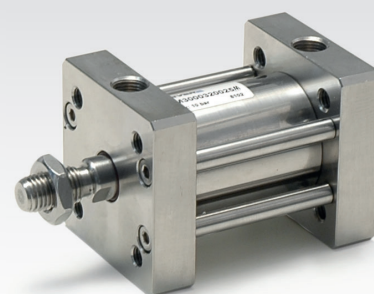

CARATTERISTICHE TECNICHE

Temperatura ambiente	0 ÷ 80 °C (-20°C con aria secca)
Fluido	aria compressa, filtrata, non lubrificata
Pressione di esercizio	1 ÷ 10 bar (doppio effetto) 2 ÷ 10 bar (semplice effetto)
Alesaggi	Ø 20 - 25 - 32 - 40 - 50 - 63 - 80 - 100 mm

CARATTERISTICHE COSTRUTTIVE

Testate	acciaio Inox AISI 316
Camicia	Ø20-25 acciaio Inox AISI 304, Ø32-100 acciaio Inox AISI 316
Pistone	alluminio
Pattino di guida	PBT+PTFE
Stelo	acciaio Inox AISI 316
Guarnizione pistone	poliuretano
Bussola guida stelo	tecnopolimero
Magnete	Ø20÷50 neodimio, Ø63÷100 plastroferrite
O-Ring	gomma nitrilica (NBR)
Tiranti	acciaio Inox AISI 316

CHIAVE DI CODIFICA

P	R	M	3	0	0	0	3	2	0	0	2	5	M	
1	2	3	4	5	6	7								

1 Serie	2 Tipologia	3 Versione	4 Alesaggio (mm)
PRM = Cilindri pneumatici inox compatti ISO 21287 Ø 20 ÷ 100 mm	1 = Stelo femmina 3 = Stelo maschio	00 = D.E. Versione standard 01 = D.E. Stelo passante 60 = S.E. Stelo retracts 70 = S.E. Stelo esteso D.E. = Doppio effetto S.E. = Semplice effetto	020 = Ø20 050 = Ø50 025 = Ø25 063 = Ø63 032 = Ø32 080 = Ø80 040 = Ø40 100 = Ø100
5 Corsa (mm)	6 Magnetico	7 Variante ATEX	
0010 = 10 0100 = 100 0250 = 250 0025 = 25 0125 = 125 0300 = 300 0050 = 50 0160 = 160 0350 = 350 0075 = 75 0200 = 200 0400 = 400	M = Versione magnetica (standard di serie)	X = ATEX (su richiesta) Per tipologia e versioni, rivolgersi al nostro Ufficio Commerciale	

Su richiesta versioni con guarnizioni per alta temperatura (Max 150°C)

Fissaggi e accessori

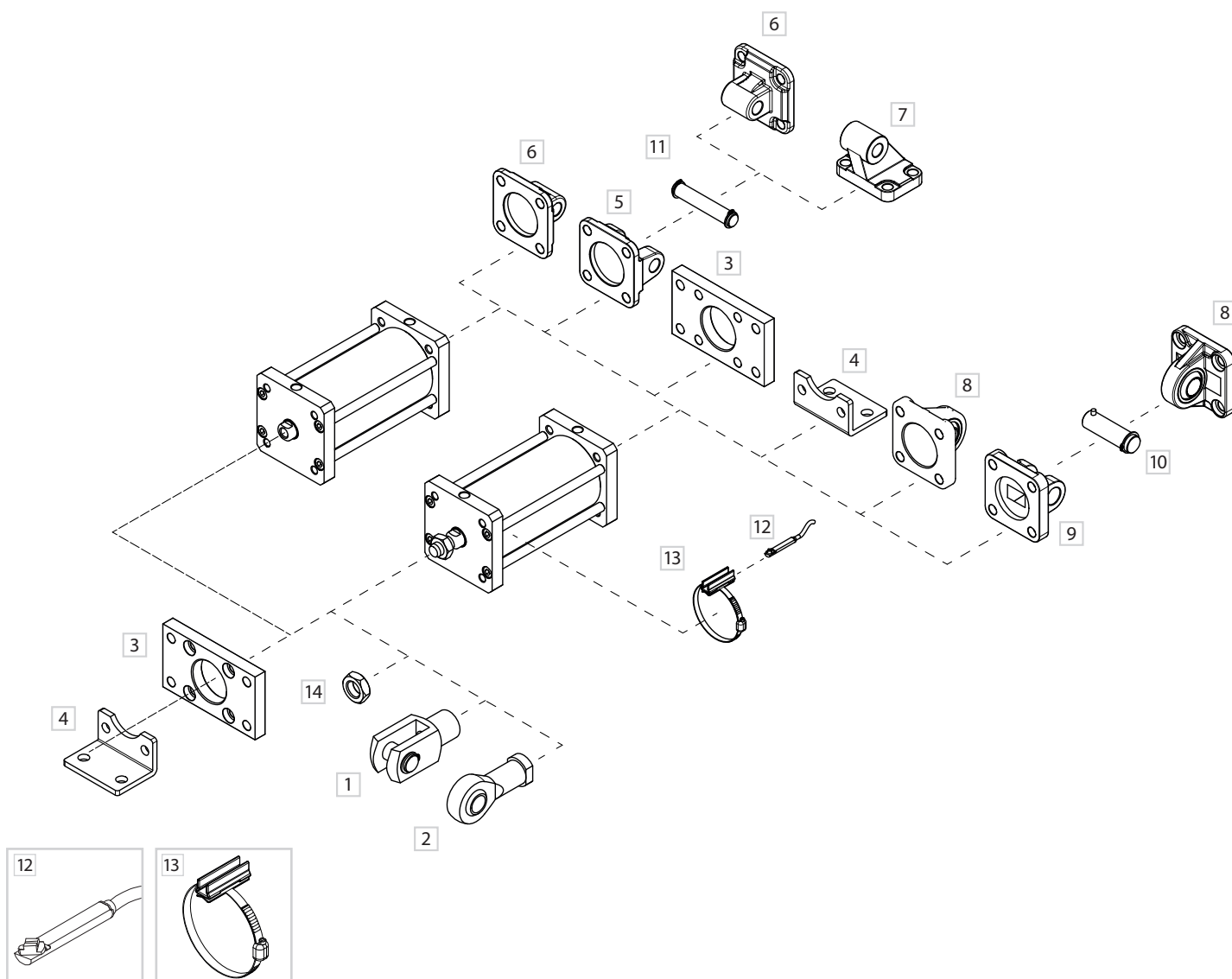

DESCRIZIONE	NOTE	CODICE
1 Forcella femmina con perno	Inox	KF-15 __ _PI
2 Forcella snodata autolubrificata	Inox	KF-17 __ _I
3 Flangia anteriore-posteriore (ISO MF1-MF2)	Inox	KF-12 __ _I
4 Piedino ad angolo (ISO MS1)	Inox	KF-13 __ _I
5 Cerniera femmina (ISO MP2)	Inox	KF-10 __ _AI
6 Cerniera posteriore maschio (ISO MP4)	Inox	KF-11 __ _I
7 Contro-cerniera 90° (CETOP RP107P)	Inox	KF-19 __ _CTAI
8 Cerniera posteriore maschio snodata (ISO MP6)	Inox	KF-11 __ _SI
9 Cerniera femmina stretta con perno (DIN648K)	Inox	KF-10 __ _ASI/
10 Perno cerniera stretta (DIN648K)	Inox	KF-18S I
11 Perno cerniera femmina (ISO MS1)	Inox	KF-18 _I
12 Sensore DF	-	DF-P700L06
13 Fascetta e adattatore DF	Inox	DH-P __ _DFI
14 Dado stelo	Inox	KF-16 __ _I

Doppio effetto



PRM100/PRM300
D.E. Standard

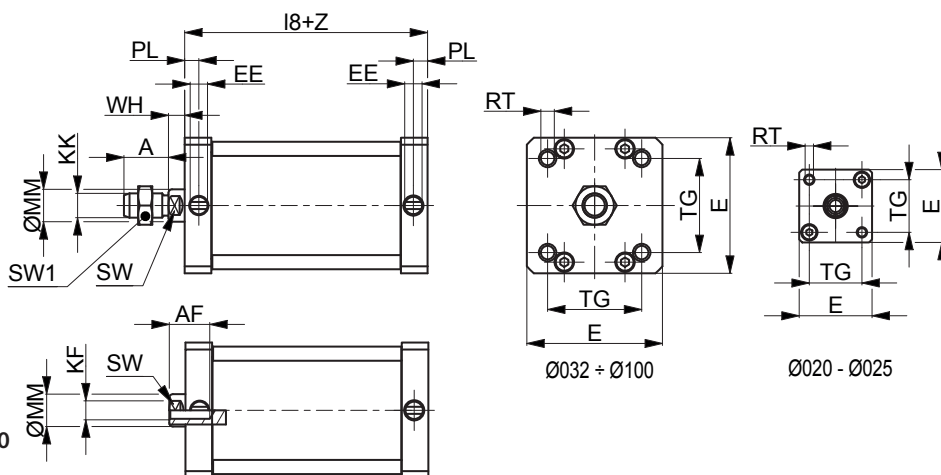

Doppio effetto stelo passante

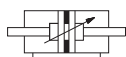

PRM101/PRP301
D.E. Stelo passante

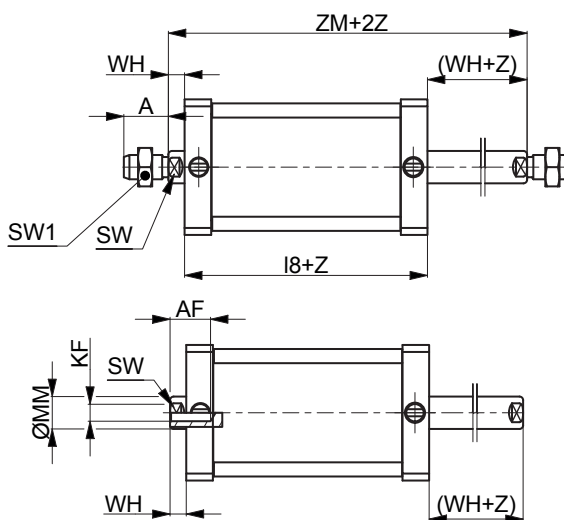

Z= Corsa

Ø	A	AF	KF	E+0,5	KK	I8	PL	RT	SW	TG	WH	ØMM	EE	SW1	ZM		
20	16	10	M6	32	M8	37	±0,3	6	M5	8	22	±0,3	6,5	10	M5x0,8	13	43,5
25	16	10	M6	36	M8	39	±0,3	6	M5	8	26	±0,3	6	10	M5x0,8	13	45
32	19	12	M8	50	M10x1,25	44	±0,4	7	M6	10	32,5	±0,5	6,5	12	G1/8	17	50,5
40	19	12	M8	57	M10x1,25	45	±0,7	7	M6	10	38	±0,6	7	12	G1/8	17	52
50	22	16	M10	67	M12x1,25	45	±0,7	7	M8	13	46,5	±0,7	8	16	G1/8	19	53
63	22	16	M10	80	M12x1,25	49	±0,8	7	M8	13	56,5	±0,7	8	16	G1/8	19	57
80	28	20	M12	96	M16x1,5	54	±0,8	7,5	M10	17	72	±0,7	10	20	G1/8	24	64
100	28	20	M12	116	M16x1,5	67	±1	7,5	M10	22	89	±1,1	10	25	G1/8	24	77

Semplice effetto stelo retratto

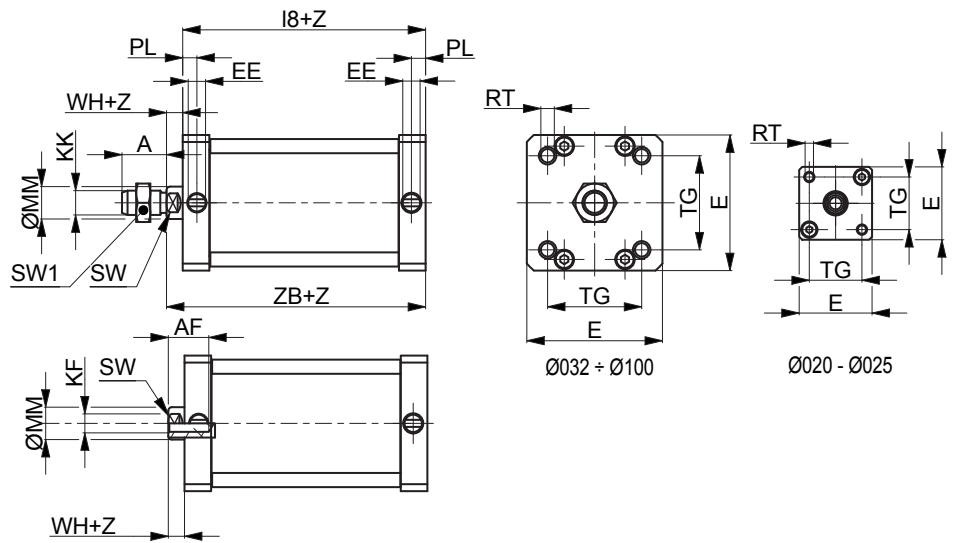

PRM160/PRM360
S.E. Stelo retratto

Z= Corsa

Ø	A	AF	KF	E+0,5	KK	I8	PL	RT	SW	TG	WH	ØMM	EE	SW1	ZB		
20	16	10	M6	32	M8	47	±0,3	6	M5	8	22	±0,3	6,5	10	M5x0,8	13	53,5
25	16	10	M6	36	M8	49	±0,3	6	M5	8	26	±0,3	6	10	M5x0,8	13	55
32	19	12	M8	50	M10x1,25	44	±0,4	7	M6	10	32,5	±0,5	6,5	12	G1/8	17	50,5
40	19	12	M8	57	M10x1,25	45	±0,7	7	M6	10	38	±0,6	7	12	G1/8	17	52
50	22	16	M10	67	M12x1,25	45	±0,7	7	M8	13	46,5	±0,7	8	16	G1/8	19	53
63	22	16	M10	80	M12x1,25	49	±0,8	7	M8	13	56,5	±0,7	8	16	G1/8	19	57
80	28	20	M12	96	M16x1,5	54	±0,8	7,5	M10	17	72	±0,7	10	20	G1/8	24	64
100	28	20	M12	116	M16x1,5	67	±1	7,5	M10	22	89	±1,1	10	25	G1/8	24	77

Semplice effetto stelo esteso

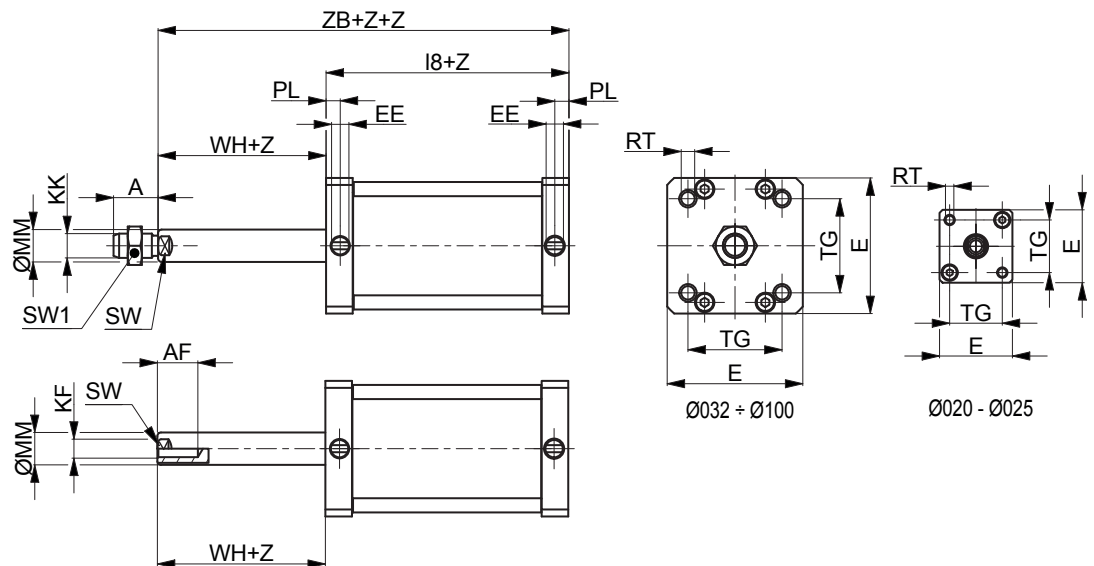

PRM170/PRM370
S.E. Stelo esteso

Z= Corsa

Ø	A	AF	KF	E+0,5	KK	I8	PL	RT	SW	TG	WH	ØMM	EE	SW1	ZB		
20	16	10	M6	32	M8	47	±0,3	6	M5	8	22	±0,3	6,5	10	M5x0,8	13	53,5
25	16	10	M6	36	M8	49	±0,3	6	M5	8	26	±0,3	6	10	M5x0,8	13	55
32	19	12	M8	50	M10x1,25	44	±0,4	7	M6	10	32,5	±0,5	6,5	12	G1/8	17	50,5
40	19	12	M8	57	M10x1,25	45	±0,7	7	M6	10	38	±0,6	7	12	G1/8	17	52
50	22	16	M10	67	M12x1,25	45	±0,7	7	M8	13	46,5	±0,7	8	16	G1/8	19	53
63	22	16	M10	80	M12x1,25	49	±0,8	7	M8	13	56,5	±0,7	8	16	G1/8	19	57
80	28	20	M12	96	M16x1,5	54	±0,8	7,5	M10	17	72	±0,7	10	20	G1/8	24	64
100	28	20	M12	116	M16x1,5	67	±1	7,5	M10	22	89	±1,1	10	25	G1/8	24	77

Cerniera femmina (ISO MP2) con perno

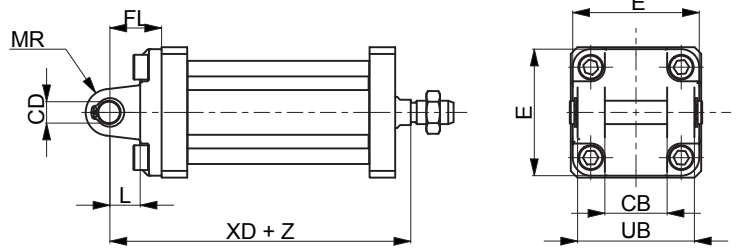
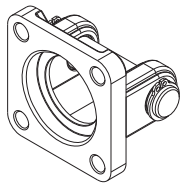

Materiale: Acciaio Inox AISI 304

Z = Corsa

Ø	CB	CD	E	FL	L	MR	UB	XD	Codice	
	H14	H9								± 0,2
20	-	-	-	-	-	-	-	-	-	
25	-	-	-	-	-	-	-	-	-	
32	26	10	48	22	12	11	45	62,5	±1,25	KF-10032AI
40	28	12	54	25	15	13	52	67	±1,25	KF-10040AI
50	32	12	65	27	15	13	60	68	±1,25	KF-10050AI
63	40	16	75	32	20	17	70	77	±1,6	KF-10063AI
80	50	16	95	36	20	17	90	84	±1,6	KF-10080AI
100	60	20	115	41	25	21	110	102	±1,6	KF-10100AI

Cerniera femmina stretta con perno (DIN648K)

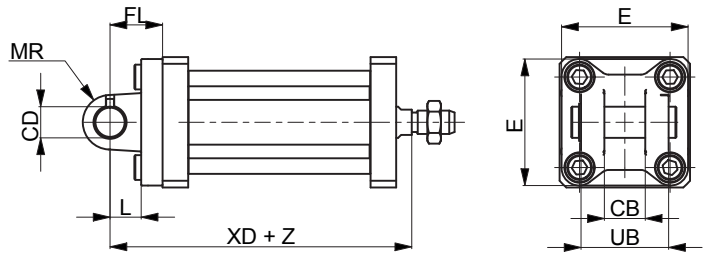
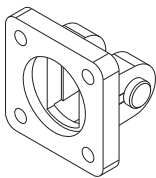

Materiale: Acciaio Inox AISI 316

Z = Corsa

Ø	CB	CD	E	FL	L	MR	UB	XD	Codice	
	H14	H9								± 0,2
20	-	-	-	-	-	-	-	-	-	
25	-	-	-	-	-	-	-	-	-	
32	14	10	45	22	10	10	34	60,5	±1,25	KF-10032ASI
40	16	12	52	25	16	12	40	68	±1,25	KF-10040ASI
50	21	16	65	27	16	14	45	69	±1,5	KF-10050ASI
63	21	16	75	32	21	18	51	78	±1,6	KF-10063ASI
80	25	20	95	36	22	20	65	86	±1,6	KF-10080ASI
100	25	20	115	41	27	22	75	104	±1,6	KF-10100ASI

Perno per cerniera femmina

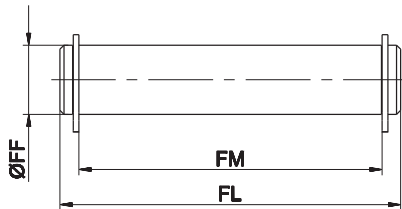

Completo di 2 seeger di arresto

Materiale: Acciaio Inox AISI 304

Ø	FF	FL	FM	Codice
	f8			
20	-	-	-	-
25	-	-	-	-
32	10	53	46	KF-18032I
40	12	61,3	53	KF-18040I
50	12	69	61	KF-18050I
63	16	80,5	71	KF-18063I
80	16	100,5	91	KF-18080I
100	20	122,5	111	KF-18100I

Perno per cerniera femmina stretta

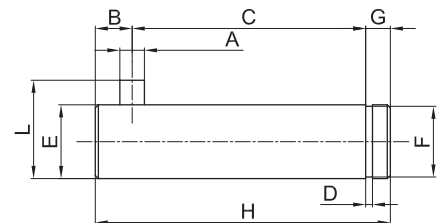

Completo di 2 seeger di arresto

Materiale: Acciaio Inox AISI 316

Ø	A	C	D	E	F	G	H	L	B	Codice	
	H12	$\pm 0,5$ $\pm 0,3$	h13	f7	h11	-	-	$\pm 0,5$			
20	-	-	-	-	-	-	-	-	-	-	
25	-	-	-	-	-	-	-	-	-	-	
32	3	32,5	1,1	10	9,6	4	41	14	4,5	KF-18032SI	
40	4	38	1,1	12	11,5	4	48	16	6	0	KF-18040SI
50	4	43	1,1	16	15,2	5	54	20	6	-1	KF-18050SI
63	4	49	1,1	16	15,2	5	60	20	6	-	KF-18063SI
80	4	63	1,3	20	19	6	75	24	6	-	KF-18080SI
100	4	73	1,3	20	19	6	85	24	6	-	KF-18100SI

Cerniera posteriore maschio (ISO MP4)

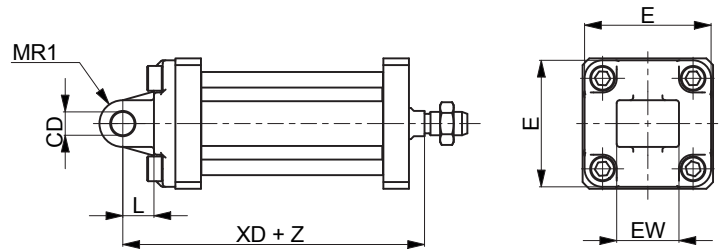
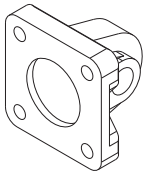

Materiale: Acciaio Inox AISI 304

Z = Corsa

Ø	CD	E	EW		L	MR1	XD	Codice
	H9				min			
20	-	-	-	-	-	-	-	-
25	-	-	-	-	-	-	-	-
32	10	48	26	-0,2/-0,6	12	15*	62,5 ±1,25	KF-11032I
40	12	54	28	-0,2/-0,6	15	18*	67 ±1,25	KF-11040I
50	12	65	32	-0,2/-0,6	15	20*	68 ±1,25	KF-11050I
63	16	75	40	-0,2/-0,6	20	23*	77 ±1,6	KF-11063I
80	16	95	50	-0,2/-0,6	20	27*	84 ±1,6	KF-11080I
100	20	115	60	-0,2/-0,6	25	29,5*	102 ±1,6	KF-11100I

* = Quote non a norma

Cerniera posteriore maschio snodata (ISO MP6)

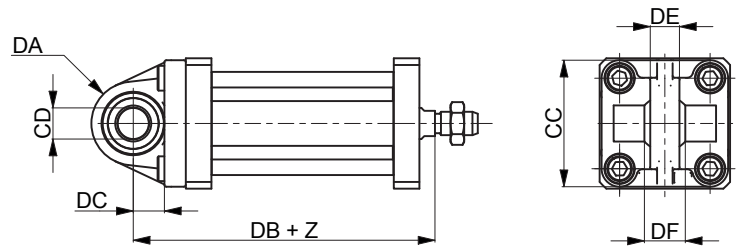
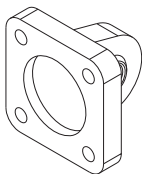

Materiale: Acciaio Inox AISI 316

Z = Corsa

Ø	CC	CD	DA	DB	DC	DE	DF	Codice
		H9						
20	-	-	-	-	-	-	-	-
25	-	-	-	-	-	-	-	-
32	48	10	15	64	14	10,5	14	KF-11032SI
40	54	12	18	68,5	16,5	12	16	KF-11040SI
50	65	12	20	70,5	17,5	12	16	KF-11050SI
63	75	16	21	78,5	21,5	15	21	KF-11063SI
80	95	16	27	88	24	15	21	KF-11080SI
100	115	20	29,5	105	28	18	25	KF-11100SI

Flangia anteriore/posteriore (ISO MF1-MF2)

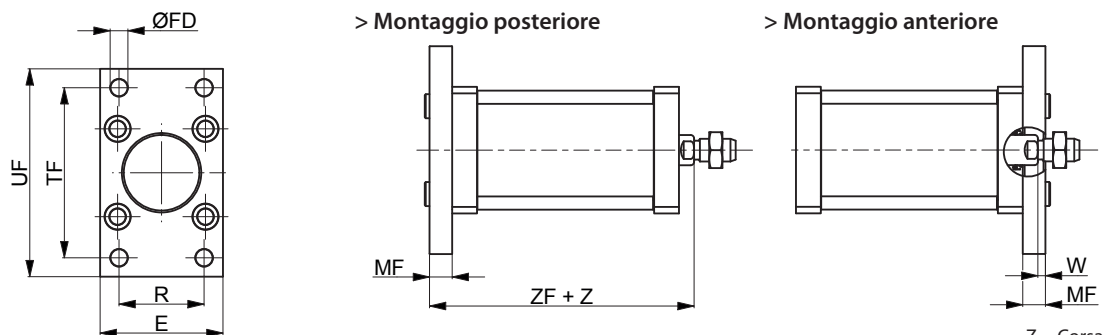
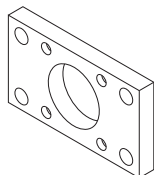

Materiale: Acciaio Inox AISI 304

Z = Corsa

Ø	E	FB	MF	R	TF	UF	W	ZF	Codice
		H13	± 0,2	JS14	JS14	Max			
20	-	-	-	-	-	-	-	-	-
25	-	-	-	-	-	-	-	-	-
32	45	7	10	32	64	80	3,5 ±1,6	54 ±1,25	KF-12032I
40	52	9	10	36	72	90	3 ±1,6	55 ±1,25	KF-12040I
50	65	9	12	45	90	110	4 ±2	57 ±1,25	KF-12050I
63	75	9	12	50	100	120	4 ±2	61 ±1,6	KF-12063I
80	95	12	16	63	126	150	6 ±2	70 ±1,6	KF-12080I
100	115	14	16	75	150	170	6 ±2	83 ±1,6	KF-12100I

Piedino ad angolo (ISO MS1)

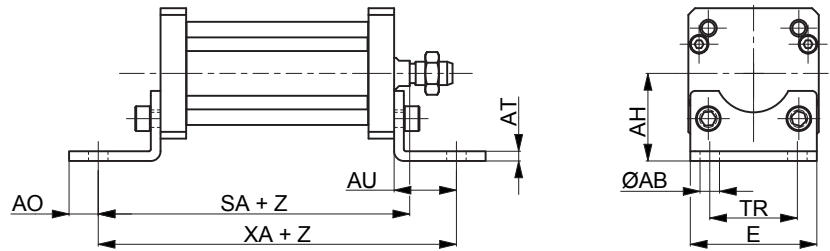
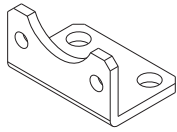

Materiale: Acciaio Inox AISI 304

Z = Corsa

Ø	ØAB	AH	AO	AT	AU	E	SA	TR	XA	Codice		
	H13	JS15									±0,2	JS14
20	-	-	-	-	-	-	-	-	-	-		
25	-	-	-	-	-	-	-	-	-	-		
32	7	32	6	4	24	45	74,5	±1,25	32	98,5	±1,25	KF-13032I
40	9	36	8	4	28	52	80	±1,25	36	108	±1,25	KF-13040I
50	9	45	10	5	32	64	85	±1,25	45	117	±1,25	KF-13050I
63	9	50	12	5	32	74	89	±1,6	50	121	±1,6	KF-13063I
80	12	63	15	6	41	94	105	±1,6	63	146	±1,6	KF-13080I
100	14	71	20	6	41	114	118	±1,6	75	159	±1,6	KF-13100I

Contro-cerniera a 90° (CETOP RP107P)

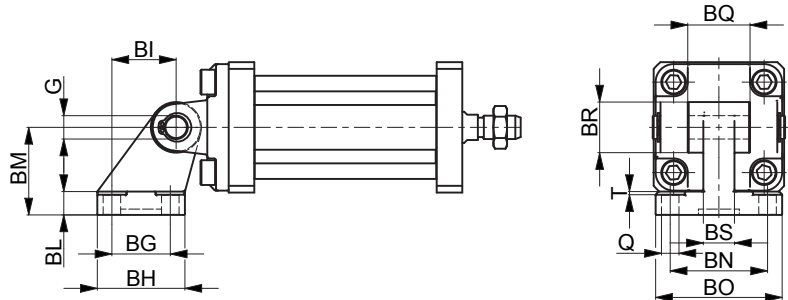
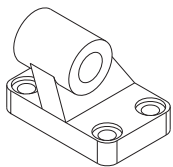

Materiale: Acciaio Inox AISI 304

Ø	Q	BG	BH	BI	BL	BM	BN	BO	BS	BR	T	G	Codice
	H13	JS14	Max	JS14		JS15	JS14	Max	Max	Max	Max	H9	
20	-	-	-	-	-	-	-	-	-	-	-	-	-
25	-	-	-	-	-	-	-	-	-	-	-	-	-
32	6,6	18	31	21	8	32	38	51	10	20	1,6	10	KF-19032CTAI
40	6,6	22	35	24	10	36	41	54	15	22	1,6	12	KF-19040CTAI
50	9	30	45	33	12	45	50	65	16	26	1,6	12	KF-19050CTAI
63	9	35	50	37	14	50	52	67	16	30	1,6	16	KF-19063CTAI
80	11	40	60	47	14	63	66	86	20	30	2,5	16	KF-19080CTAI
100	11	50	70	55	17	71	76	96	20	38	2,5	20	KF-19100CTAI

Forcella femmina con perno

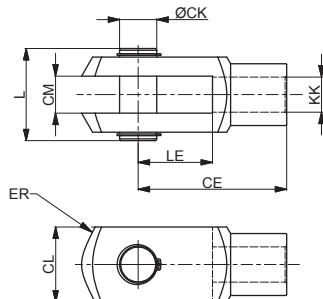
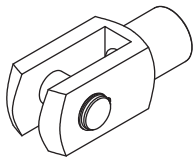

Materiale: Acciaio Inox AISI 304

Ø	CE	CK	CL	CM	ER	KK	L	LE	Codice
20 - 25	32	8	16	8	10	M8x1,25	22	16	MF-15020PI
32 - 40	40	10	20	10	16	M10x1,25	26	20	KF-15032PI
50 - 63	48	12	24	12	19	M12x1,25	32	24	KF-15040PI
80 - 100	64	16	32	16	25	M16x1,5	40	32	KF-15050PI

Forcella snodata autolubrificata

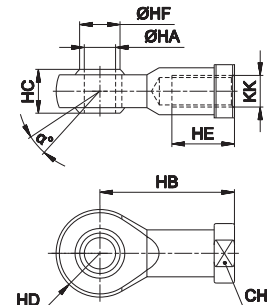
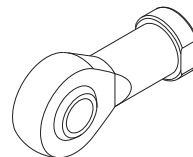

Materiale: Acciaio Inox AISI 304

Ø	α°	CH	KK	HA	HB	HC	HD	HE	HF	Codice
20 - 25	14	14	M8x1,25	8	36	12	12	16	10,4	MF-17020I
32 - 40	13	17	M10x1,25	10	43	14	14	20	12,9	KF-17032I
50 - 63	13	19	M12x1,25	12	50	16	16	22	15,4	KF-17040I
80 - 100	15	22	M16x1,5	16	64	21	21	28	19,3	KF-17050I

Forcella adatta per stelo a norma ISO 8140 completa di perno

Dado per stelo

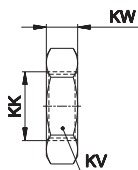
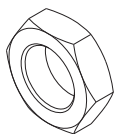

Materiale: Acciaio Inox AISI 304

Ø	KK	KV	KW	Codice
20 - 25	M8x1,25	13	5	MF-16020I
32 - 40	M10x1,25	17	6	KF-16032I
50 - 63	M12x1,25	19	7	KF-16040I
80 - 100	M16x1,5	24	8	KF-16050I

Fascetta per sensori DF

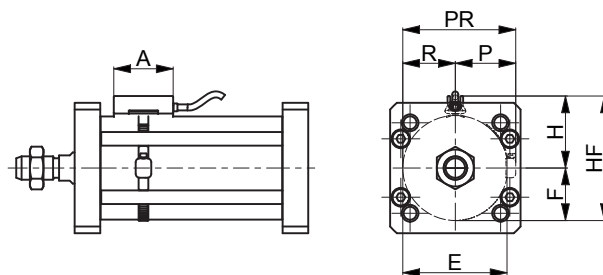
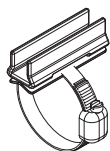

Materiale: Acciaio Inox AISI 303

Ø	A	E	H	F	HF	P	R	PR	Codice
20	34	24	20	12	32	17	12	29	DH-P020DFI
25	34	32	23	16	39	19	16	35	DH-P025032DFI
32	34	41,5	53	16,75	94,5	47	41,5	88,5	DH-P025032DFI
40	34	51,5	63	20,75	114,5	57	51,5	108,5	DH-P040DFI
50	34	64,5	76	25,75	140,5	70	64,5	134,5	DH-P050DFI
63	34	81,5	93	32,25	174,5	87	81,5	168,5	DH-P063DFI
80	34	101,5	113	40,75	214,5	107	101,5	208,5	DH-P080DFI
100	34	126,5	138	50,75	264,5	132	126,5	258,5	DH-P100DFI

Per sensori serie DF vedi sezione accessori

Sensore DF

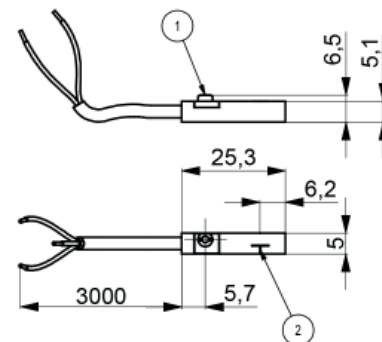
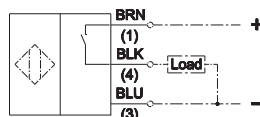
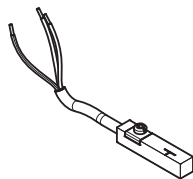

1	2	Codice
eccentrico di fissaggio	superficie attiva	DF-P700L06

UNIVER S.p.A.

Sede centrale

I - 20128 **Milano**
Via Eraclito, 31
Tel. +39 02 25298.1
Fax +39 02 2575254
info@univer-group.com
www.univer-group.com

UNIVER SERVICE S.r.l.

Sede centrale

I - 20128 **Milano**
Via Empedocle, 20
Tel. +39 02 25298.1
Fax +39 02 25298370
universervice@universervice.it
www.universervice.it

Unità operative

LOMBARDIA

I - 20099 - Sesto San Giovanni **Milano**
Via G. di Vittorio, 307/20
Tel. +39 02 26261304
Fax +39 02 24300375
universervice@universervice.it

PIEMONTE/LIGURIA/VALLE D'AOSTA

I - 10071 Borgaro Torinese **Torino**
Via Veneto, 18
Tel. +39 011 4501871
Fax +39 011 4502898
torino@universervice.it

VENETO/FRIULI VENEZIA-GIULIA TRENTINO-ALTO ADIGE

I - 30030 Vigonovo **Venezia**
Via Prima strada 16/A - Loc. Galta
Tel. +39 049 9834140
Fax +39 049 9833972
vigonovo@universervice.it

EMILIA ROMAGNA

I - 40069 Zola Predosa **Bologna**
Via Guido Rossa, 21
Tel. +39 051 753907
Fax +39 051 6184751
bologna@universervice.it

CENTRO/SUD

I - 40069 Zola Predosa **Bologna**
Via Guido Rossa, 21
Tel. +39 051 753907
Fax +39 051 6184751
bologna@universervice.it

UNIVER DO BRASIL S/A

BRASILE - 13474-764
Americana **São Paulo - SP**
Rua do Polyester, 29
Distrito Industrial Abdo Najar
Tel. +55 19 3113-9400
Fax +55 19 3113-9405
atendimento@univer.com.br

UNIVER CHINA

CINA - Shanghai
399 Fu Te North Road,
Free Zone, Pudong
info@univer-china.com

UNIVER FRANCE S.a.s.

FRANCIA - 68000
Colmar
1, rue Denis Papin
Tel. +33 03 89210900
Fax +33 03 89216850
info@univer-france.fr

UNIVER G.m.b.H.

GERMANIA - D-65428
Rüsselsheim
Eisenstraße 51
Tel. +49 6142 40832-0
Fax +49 6142 40832-90
info@univer-gmbh.de

UNIVER NORTH AMERICA

USA - 48312
Sterling Heights - **Michigan**
6620 Cobb Drive
Tel. +1 248 299 0525
Fax +1 248 299 0528
info@univer-group.us

UNIVER POLSKA Sp. z o.o.

POLONIA - 25-663
Kielce
ul. K. Olszewskiego 21E
Tel. +48 41 278 72 53
Fax +48 41 278 72 54
univer@univer-group.pl

UNIVER S.L.

SPAGNA - 08210
Barbera Del Valles **Barcelona**
Ronda Industria, 26 - 28
Tel. +34 93 7297360
Fax +34 93 7297380
univer@univerweb.com

Distributori nel mondo:

Rivolgersi all'ufficio commerciale o
visitare il sito www.univer-group.com



www.univer-group.com