

LAGE1000

Power pivot

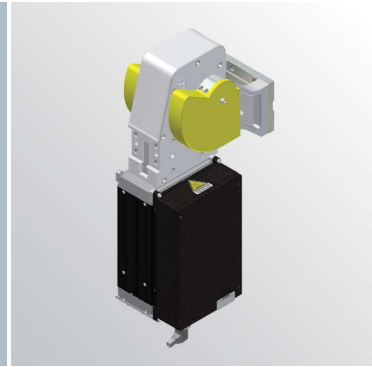

L	A	G	E	1	0	0	0	V	D	0
1				2			3	4	5	

1 Series	2 Size	3 Pivot mount style
LAGE = Power pivot	1000	V = Vertical 180° O = Horizontal 90° Z = Vertical mount style symmetrical to V mount style. Max. opening angle 120° P = Horizontal mount style symmetrical to O mount style. Max. opening angle 60°

4 Control Module Position	5 Voltage
D = Right S = Left R = Remoted - cable to be ordered separately	O = 400 Vac 1 = 480 Vac 2 = 3-phase 203 Vac

Pivot rotation in degrees:

- 120°
- 90° (Standard)
- 60°
- 45°

Pivot mount style

V = 90°

O = 180°

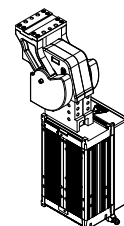
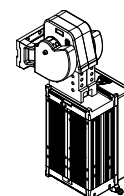

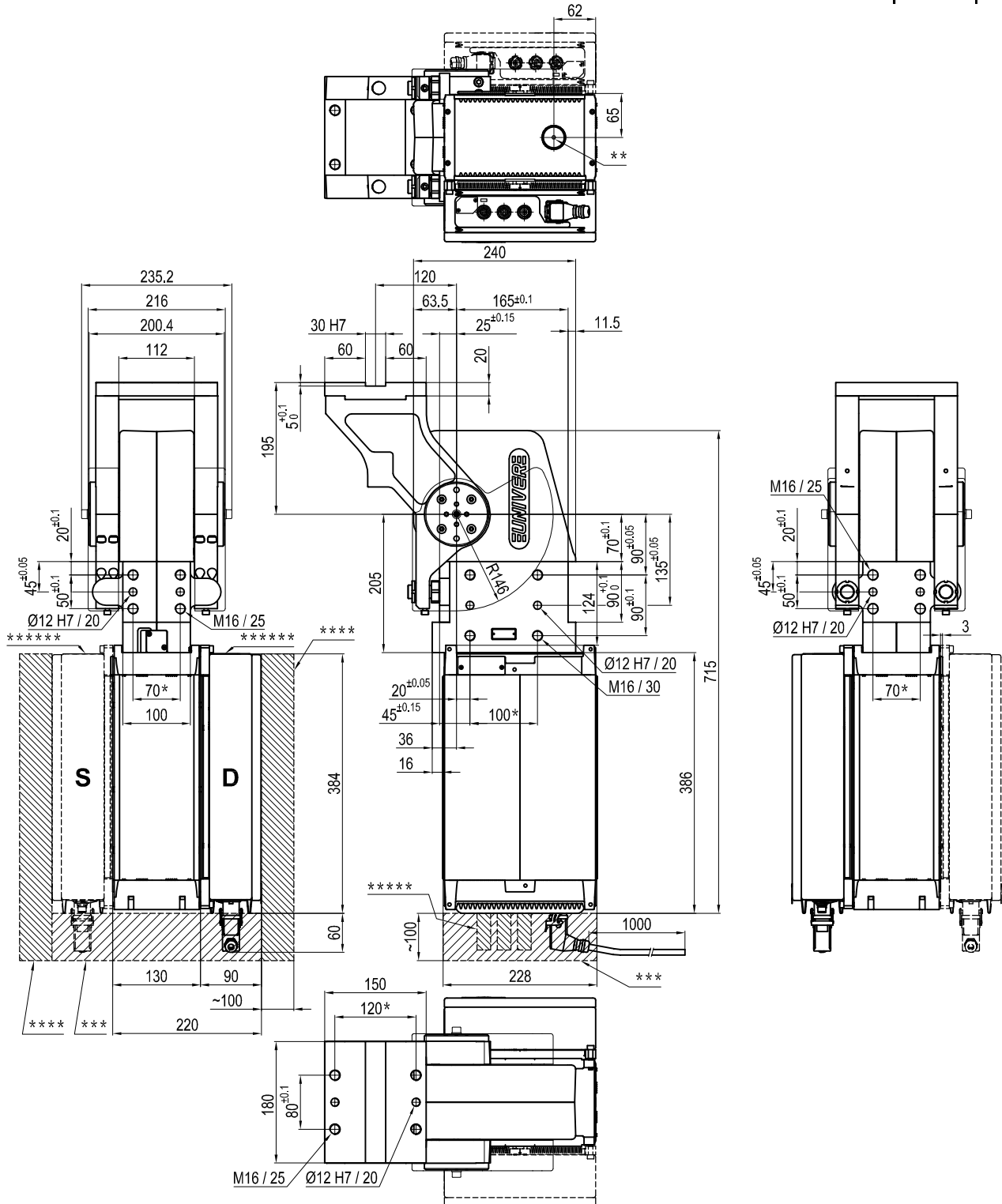

Size	Holding moment	Max bending moment with nominal voltage	Time to close	Weight
1000	8000 Nm	1000 Nm	2,1 + 3,7 Sec.x 90°	66.5 Kg

Operating temperature: $5^{\circ} \pm 45^{\circ} \text{C}$
 Predeterminable pivot rotation in degrees: $45^{\circ} - 60^{\circ} - 90^{\circ} - 120^{\circ}$
 Horizontal arm mount position
 Protection class: **IP 65**

- * : TOLERANCE BETWEEN DOWEL HOLES ± 0.02 , TO SCREW HOLES ± 0.1
- ** : MANUAL OPERATION: COVER KEY $\odot = 5$, KEY TO MOVE THE TABLE $\odot = 10$
- *** : SPACE FOR MANUAL OPERATIONS
- **** : SPACE FOR OPERATING ON THE ELECTRONIC COMPONENTS
- ***** : ROOM FOR CONNECTORS
- ***** : CONTROL UNIT MOUNTING POSITION : D= RIGHT ; L= LEFT

Subject to technical modifications without notice

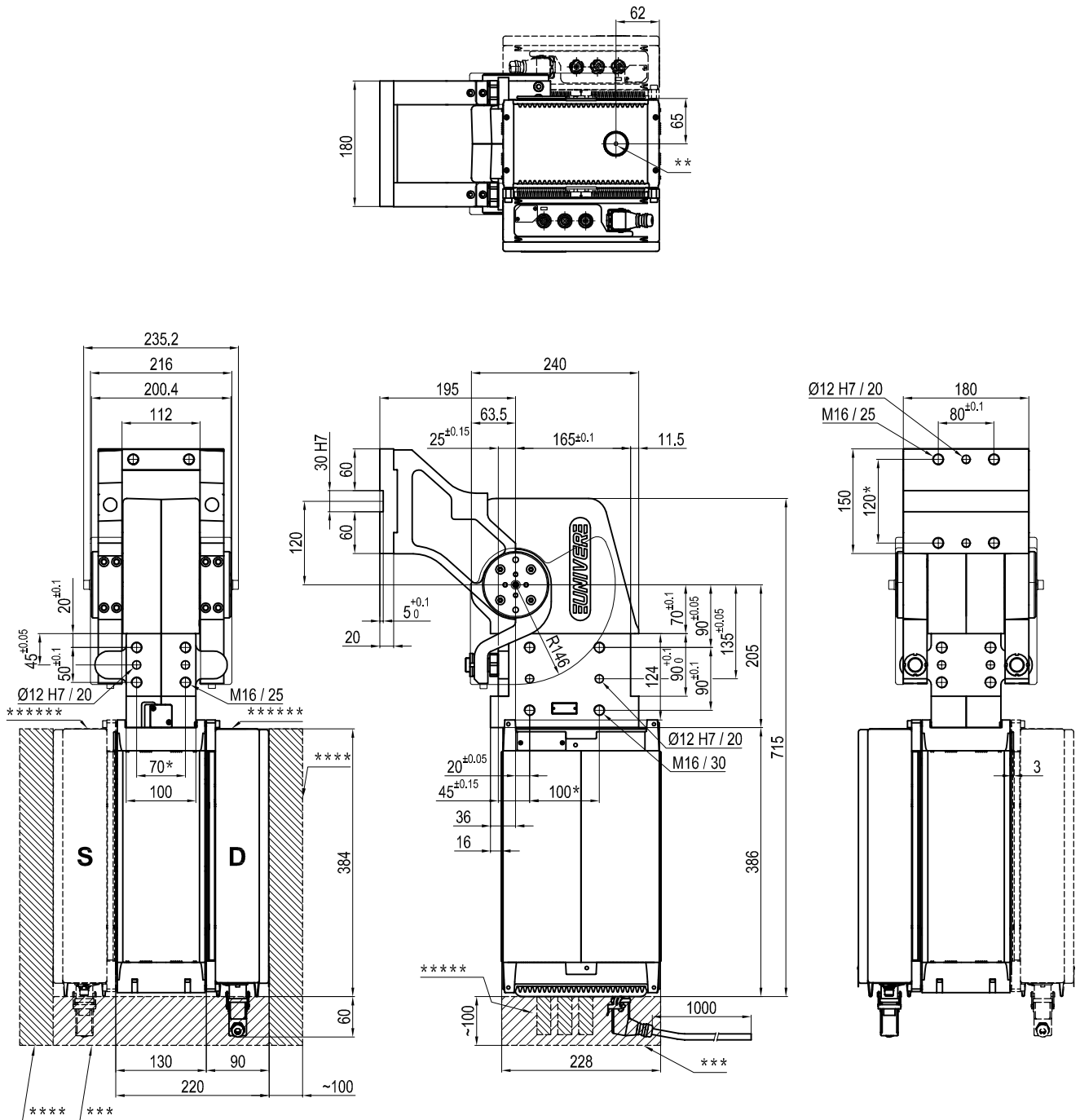

Size	Holding moment	Max bending moment with nominal voltage	Time to close	Weight
1000	8000 Nm	1000 Nm	2,1 + 3,7 Sec.x 90°	66.5 Kg

Operating temperature: $5^{\circ} \pm 45^{\circ} \text{C}$
 Predeterminable pivot rotation in degrees: $45^{\circ} - 60^{\circ} - 90^{\circ} - 120^{\circ}$
 Vertical arm mount position
 Protection class: **IP 65**

- * : TOLERANCE BETWEEN DOWEL HOLES ± 0.02 , TO SCREW HOLES ± 0.1
- ** : MANUAL OPERATION: COVER KEY $\odot = 5$, KEY TO MOVE THE TABLE $\odot = 10$
- *** : SPACE FOR MANUAL OPERATIONS
- **** : SPACE FOR OPERATING ON THE ELECTRONIC COMPONENTS
- ***** : ROOM FOR CONNECTORS
- ***** : CONTROL UNIT MOUNTING POSITION : D= RIGHT ; L= LEFT

Subject to technical modifications without notice

Electric power pivot

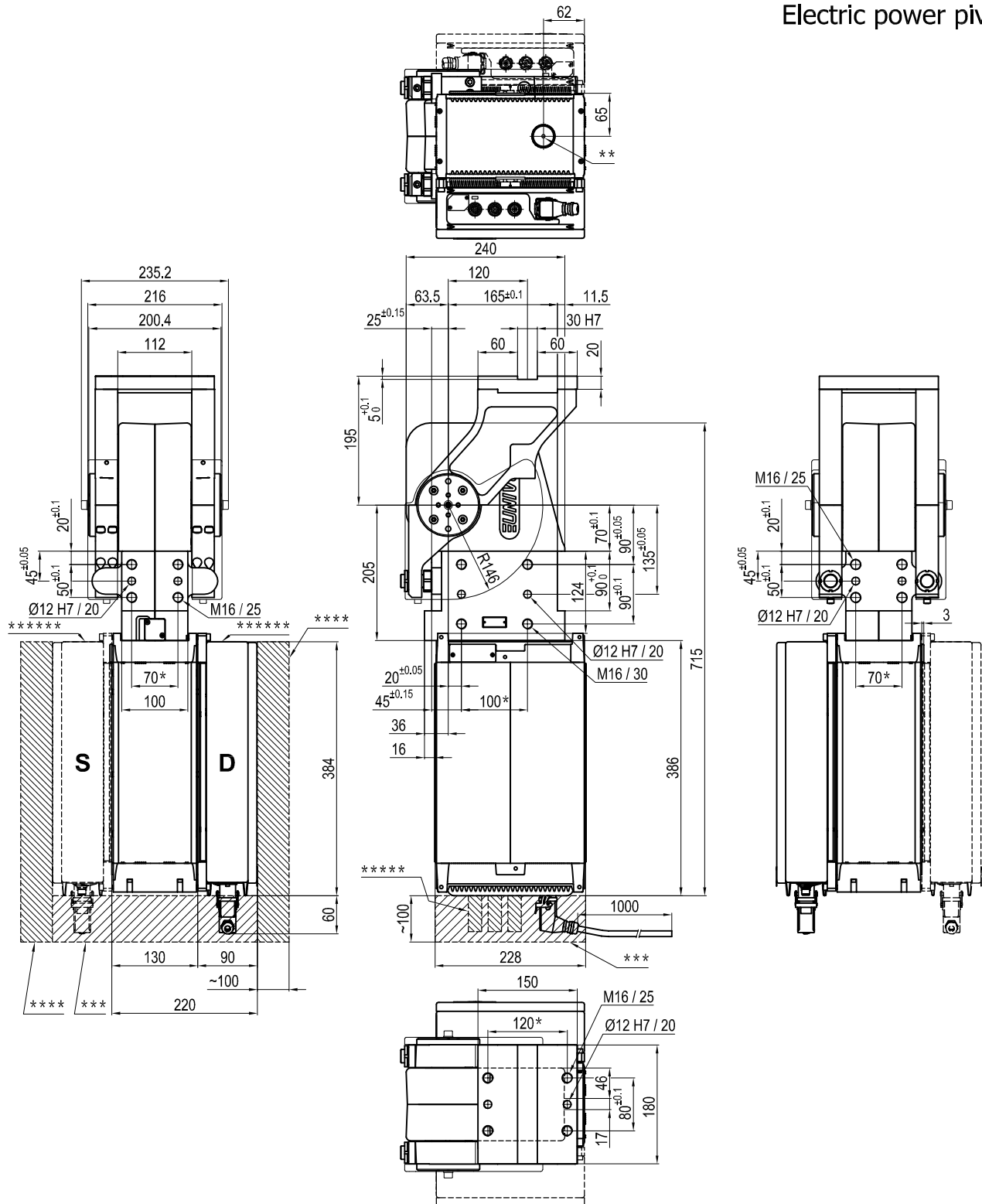

Size	Holding moment	Max bending moment with nominal voltage	Time to close	Weight
1000	8000 Nm	1000 Nm	2,1 + 3,7 Sec.x 90°	66.5 Kg

Operating temperature: $5^{\circ} \pm 45^{\circ} \text{C}$
 Predeterminable pivot rotation in degrees: $45^{\circ} - 60^{\circ} - 90^{\circ} - 120^{\circ}$
 Horizontal arm mount position
 Protection class: **IP 65**

- * : TOLERANCE BETWEEN DOWEL HOLES ± 0.02 , TO SCREW HOLES ± 0.1
- ** : MANUAL OPERATION: COVER KEY $\odot = 5$, KEY TO MOVE THE TABLE $\odot = 10$
- *** : SPACE FOR MANUAL OPERATIONS
- **** : SPACE FOR OPERATING ON THE ELECTRONIC COMPONENTS
- ***** : ROOM FOR CONNECTORS
- ***** : CONTROL UNIT MOUNTING POSITION : D= RIGHT ; L= LEFT

Subject to technical modifications without notice

It will always be supplied with LKMOSC and TZ-CVLAGE-__ _

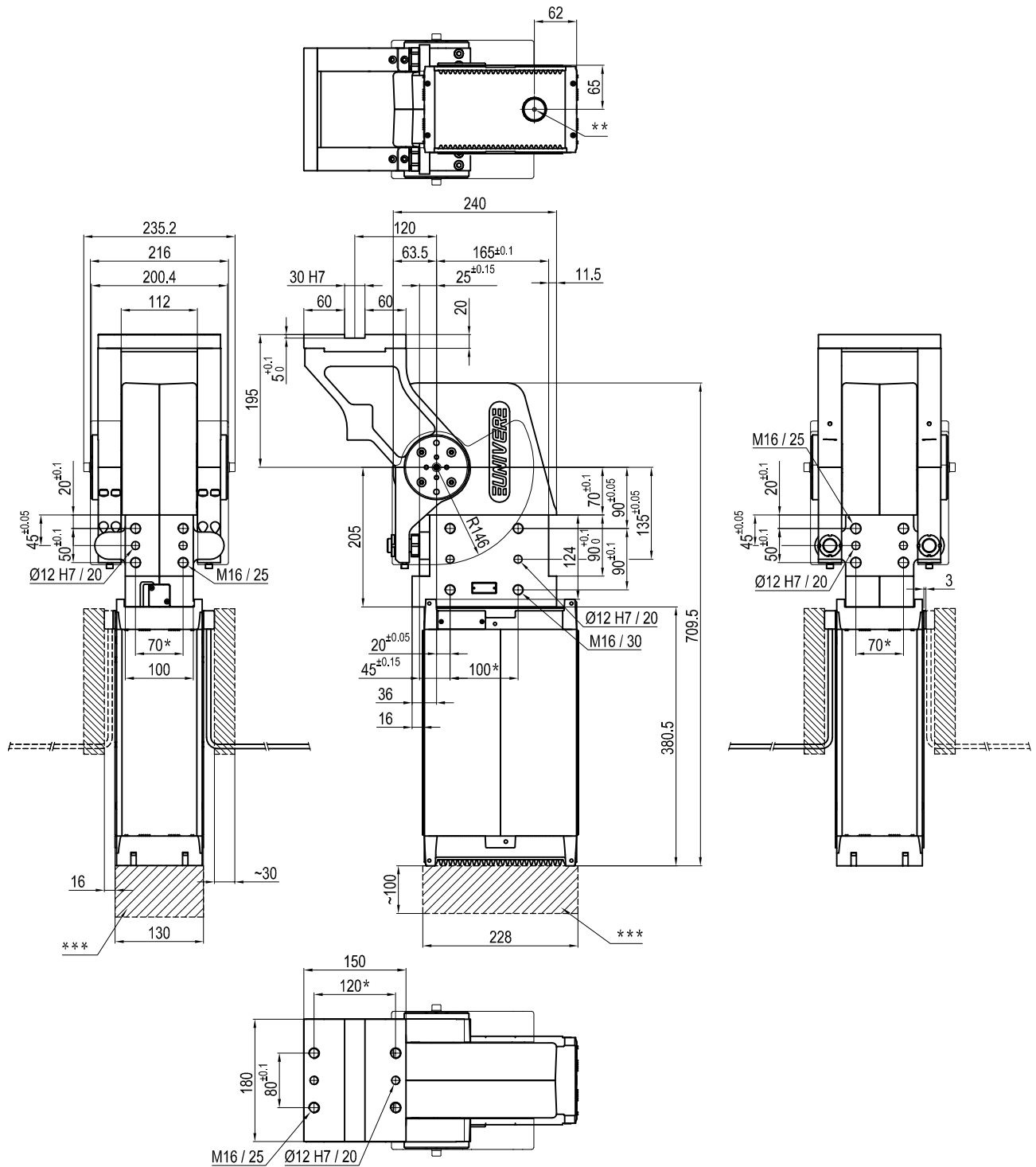

Size	Holding moment	Max bending moment with nominal voltage	Time to close	Weight
1000	8000 Nm	1000 Nm	2,1 + 3,7 Sec.x 90°	52.5 Kg

Operating temperature: $5^{\circ} \pm 45^{\circ} \text{C}$
 Predeterminable pivot rotation in degrees: $45^{\circ} - 60^{\circ} - 90^{\circ} - 120^{\circ}$
 Horizontal arm mount position
 Protection class: **IP 65**

* : TOLERANCE BETWEEN DOWEL HOLES ± 0.02 , TO SCREW HOLES ± 0.1
 ** : MANUAL OPERATION: COVER KEY $\odot = 5$, KEY TO MOVE THE TABLE $\odot = 10$
 *** : SPACE FOR MANUAL OPERATIONS

Subject to technical modifications without notice

It will always be supplied with LKMOSC and TZ-CVLAGE-__ _

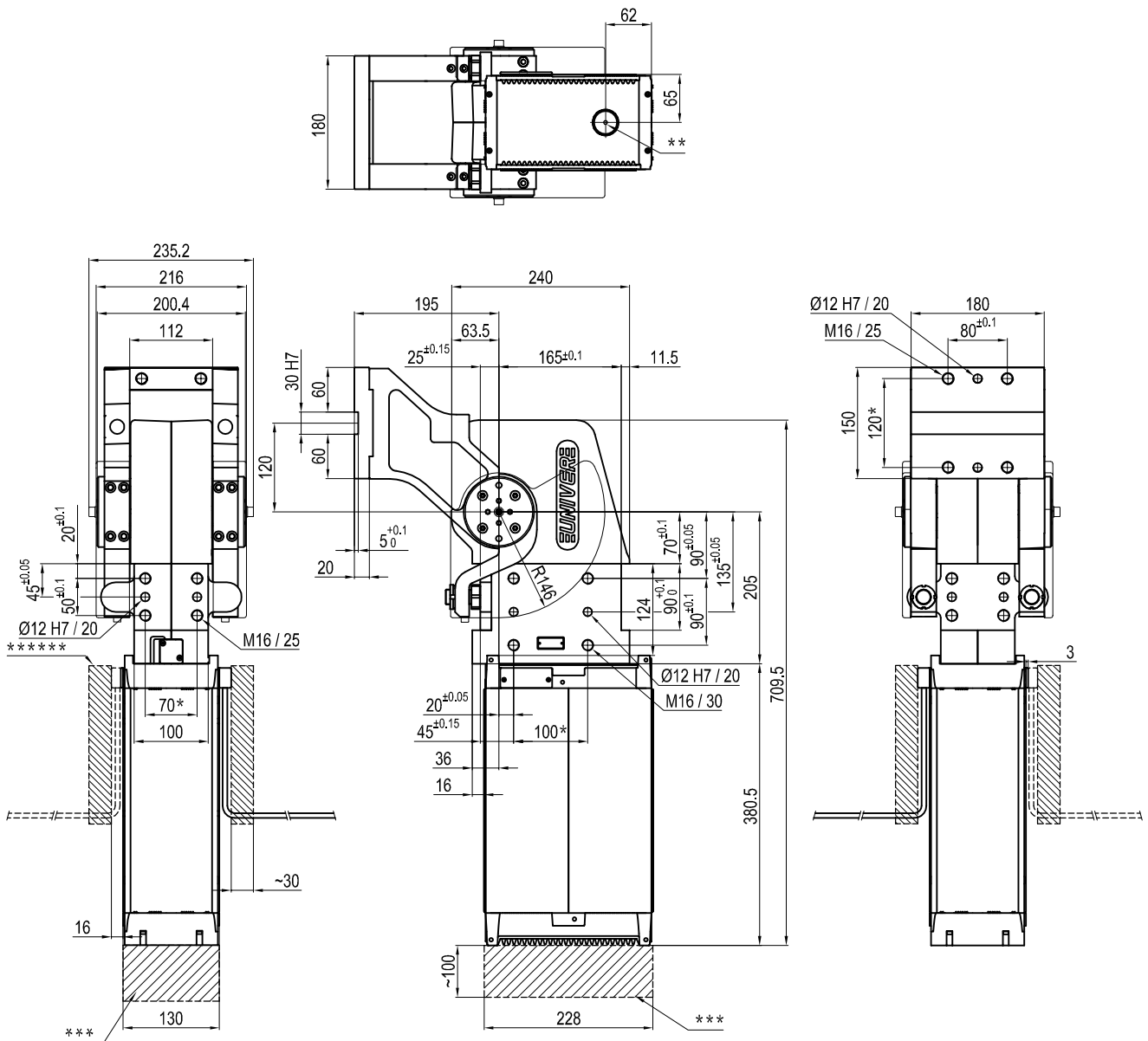

Size	Holding moment	Max bending moment with nominal voltage	Time to close	Weight
1000	8000 Nm	1000 Nm	2,1 + 3,7 Sec.x 90°	52.5 Kg

Operating temperature: $5^{\circ} \pm 45^{\circ} \text{C}$
 Predeterminable pivot rotation in degrees: $45^{\circ} - 60^{\circ} - 90^{\circ} - 120^{\circ}$
 Vertical arm mount position
 Protection class: **IP 65**

* : TOLERANCE BETWEEN DOWEL HOLES ± 0.02 , TO SCREW HOLES ± 0.1
 ** : MANUAL OPERATION: COVER KEY $\odot = 5$, KEY TO MOVE THE TABLE $\ominus = 10$
 *** : SPACE FOR MANUAL OPERATIONS

Subject to technical modifications without notice

Remoted control unit for LAGE0500 - LAGE1000

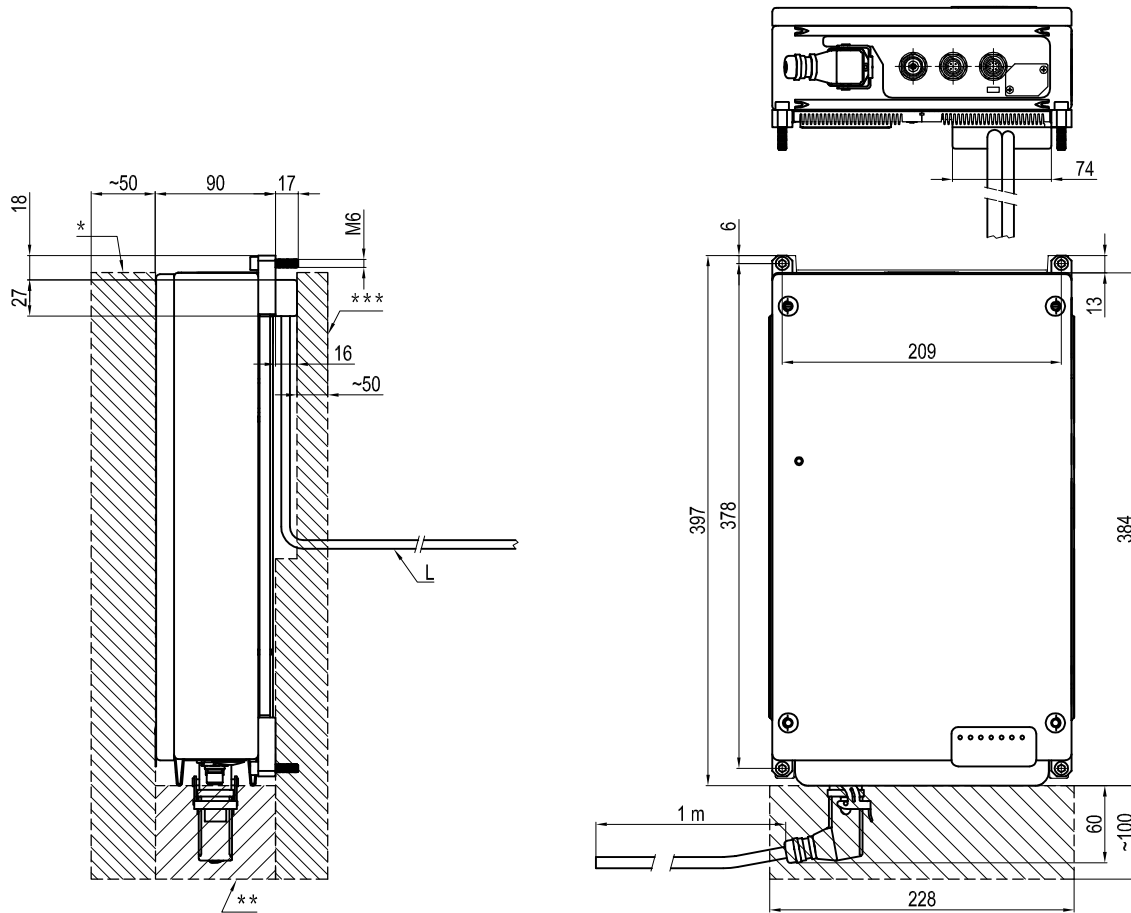

* : SPACE FOR OPERATING ON THE ELECTRONIC COMPONENTS
 ** : ROOM FOR CONNECTORS
 *** : SPACE TO REMOTE THE CONTROL UNIT

Operating temperature : $5^{\circ} \pm 45^{\circ} \text{ C}$
 Protection class :IP 65

TZ-CVLAGE-__

Cable for the connection between the power pivot and remote control unit: available in 4 lenghts

Ordering code	L
TZ-CVLAGE-050	5 m
TZ-CVLAGE-100	10 m
TZ-CVLAGE-150	15 m
TZ-CVLAGE-200	20 m

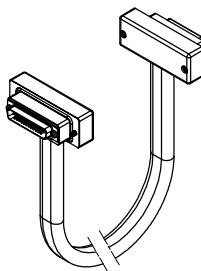

Operating temperature : $5^{\circ} \pm 45^{\circ} \text{ C}$
 Protection class :IP 65