

The pneumatic cylinders with digital measuring of the position derive from the respective fluidic axes with numerical control and are particularly suitable for:

- ✓ **Control of the locking position**
- ✓ **Anticollision control for cycles with critical sequence**
- ✓ **Level control relating to the palletization and/or depalletization of objects placed one onto the other**
- ✓ **Identification, classification and dimensional choice of objects (tolerances and rejects)**
- ✓ **Certification stations of machined pieces or breaking of tools on machines due to chip removal.**

The device can be used in two different ways:

- **as digital measuring detector**
- **as pneumatic actuator with digital detection of the position.**

In the first case the system does not need to be connected to the moving part of the mechanism as it generates by itself the movement by means of an internal pusher with bidirectional pneumatic function at low pressure. This pusher, operated by a 5-way microvalve, moves autonomously until it meets the obstacle and measures the position by means of the encoder whose indication may be visualized on a digital display with centesimal resolution. The precision repeatability is $\pm 0,02 \text{ mm}$.

The speed of the impact against the obstacle is limited by appropriate calibrated reducers which are built into the detector, whilst it is possible to adequately regulate the translation speed by means of a normal pressure regulator. In order to guarantee a reading with the indicated repeatability, the translation speed must be as constant as possible.

In the second case the air supply of the device is effected by means of the network pressure adequately regulated according to the necessity; it depends on the load to be moved or is prearranged to exert the desired thrust once reached the object to be detected.

Codification key

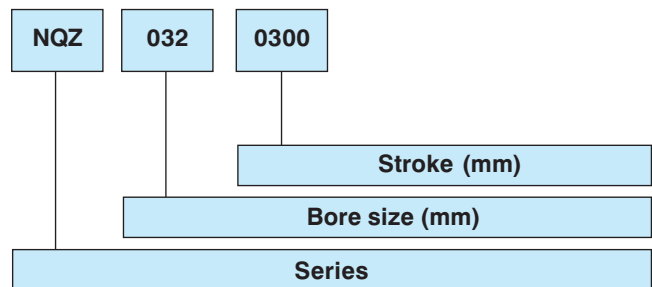

SERIES

NQZ = Pneumatic actuator with digital detector of the position.

BORE SIZE

032 - 040 - 050 - 063 mm

MAX. STROKE

350 mm for Ø 32
 450 mm for Ø 40
 650 mm for Ø 50
 700 mm for Ø 63

N.B. When the detector is used in environments with electromagnetic disturbances exceeding those allowed by the EN50081-2 standard, also request the adapter TAE011A10305 (our production) or suppressors of electromagnetic interferences available on the market.

Technical characteristics

| | | | | | | | | | | | |
|----------------------|---|----|------|----|----|----|---------|----|----|------|--|
| Working pressure | 2 ÷ 10 bar | | | | | | | | | | |
| Ambient temperature: | -10 ÷ 70°C | | | | | | | | | | |
| Fluid | filtered air 30 µm | | | | | | | | | | |
| Bore size | 032 - 040 - 050 - 063 mm | | | | | | | | | | |
| Standard stroke | depending on bore size (refer to codification key) | | | | | | | | | | |
| Barrel | extruded barrel in aluminium alloy with groove for flush-mounted sensors | | | | | | | | | | |
| Piston rod | chromium-plated steel | | | | | | | | | | |
| Thread of the screw | <table border="1"> <tr> <td>Ø</td> <td>32</td> <td>40</td> <td>50</td> <td>63</td> </tr> <tr> <td>mm/turn</td> <td>12</td> <td>16</td> <td>20,5</td> <td></td> </tr> </table> | Ø | 32 | 40 | 50 | 63 | mm/turn | 12 | 16 | 20,5 | |
| Ø | 32 | 40 | 50 | 63 | | | | | | | |
| mm/turn | 12 | 16 | 20,5 | | | | | | | | |

| | |
|----------------------------|---------------------------------------|
| Max. speed | 0,2 m/s (detector) 0,8 m/s (actuator) |
| Precision of repeatability | ± 0,02 mm |

Electrical characteristics

| | |
|-----------------------------|-----------------------------------|
| Power supply | 5 V dc |
| Output | Level "L" < 0,5V Level "H" Vdc |
| Limit frequency | 60 KHz |
| Impedance | 2 Kohm |
| Consumption of current | 40 mA max |
| Time of upstroke/downstroke | < 1µS |
| Pulse rate | 500 |
| Resolution | ± 0,01 pulses/turn |
| Working temperature | - 10° ÷ +70 |

Scheme of encoder

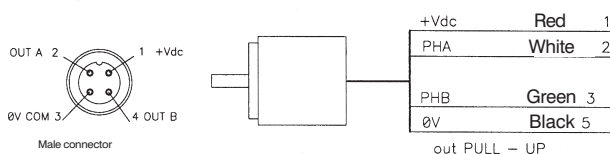

Overall dimensions

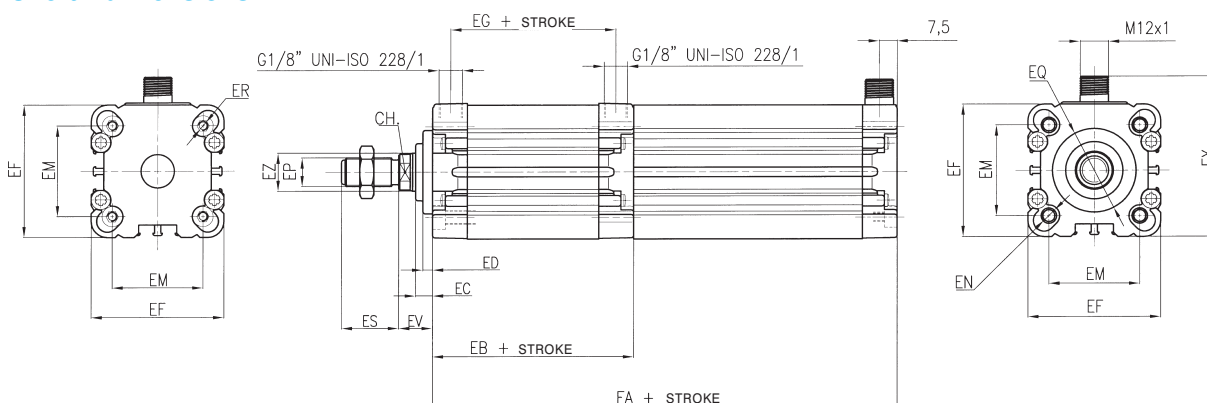

| Ø | EA | EB | EC | ED | EF | EG | EM | EN | EP | EQ | ER | ES | EV | EX | EZ | CH |
|----|-----|-----|----|----|----|------|------|-----------|------------|------|---------|----|----|----|----|----|
| 32 | 186 | 84 | 7 | 4 | 46 | 68,5 | 32,5 | M6 x 13 | M10 x 1,25 | ø 30 | M4 x 10 | 22 | 14 | 57 | 12 | 10 |
| 40 | 194 | 89 | 7 | 4 | 56 | 74 | 38 | M6 x 13 | M12 x 1,25 | ø 35 | M4 x 10 | 24 | 14 | 67 | 16 | 13 |
| 50 | 204 | 94 | 10 | 5 | 66 | 79 | 46,5 | M8 x 17,5 | M16 x 1,25 | ø 40 | M6 x 10 | 32 | 18 | 77 | 20 | 17 |
| 63 | 223 | 114 | 10 | 5 | 79 | 99 | 56,5 | M8 x 18 | M16 x 1,25 | ø 45 | M6 x 10 | 32 | 18 | 90 | 20 | 17 |

Accessories

- **Mounting accessories:** same as for cylinders STRONG series (Sect. Cylinders page 49-I)
- **Flush-mounted magnetic sensor DF-...series** (Sect. Accessories page 2-V)
- **Strap for covering wires of magnetic sensor DHF-002100**