

LAGP075

Pneumatic power pivot



L	A	G	P	0	7	5	V	E	0	9	0	B	C	
1	2	3	4	5	6	7	8	9						

1 Series	2 Version	3 Size
-----------------	------------------	---------------

LAG = Power pivot with predeterminate pivot rotation angles

P = Pneumatic-standard

075 = Ø 80 mm cylinder

4 Table position	5 Sensor	6 Pivot rotation angles
-------------------------	-----------------	--------------------------------

V = Vertical 180°
O = Horizontal 90°
Z = Vertical, mirror of V position
 Max opening angle 120°
P = Horizontal, mirror of O position
 Max opening angle 60°

E = Electronic sensor with M12 swivel connector
A = Electronic sensor with M12 swivel connector + electronic sensor for brake condition detection

120 = 120°
090 = 90°
060 = 60°
045 = 45°

7 Brake system	8 Valve	9 Connections
-----------------------	----------------	----------------------

B = With brake
W = Without brake

C = Integrated valve for cycle time optimization

_ = If not specified, on the left side (sensor left side)
D = Right side (sensor right side)
F = Front side (in front of the sensor)
P = Rear side (same side as sensor)

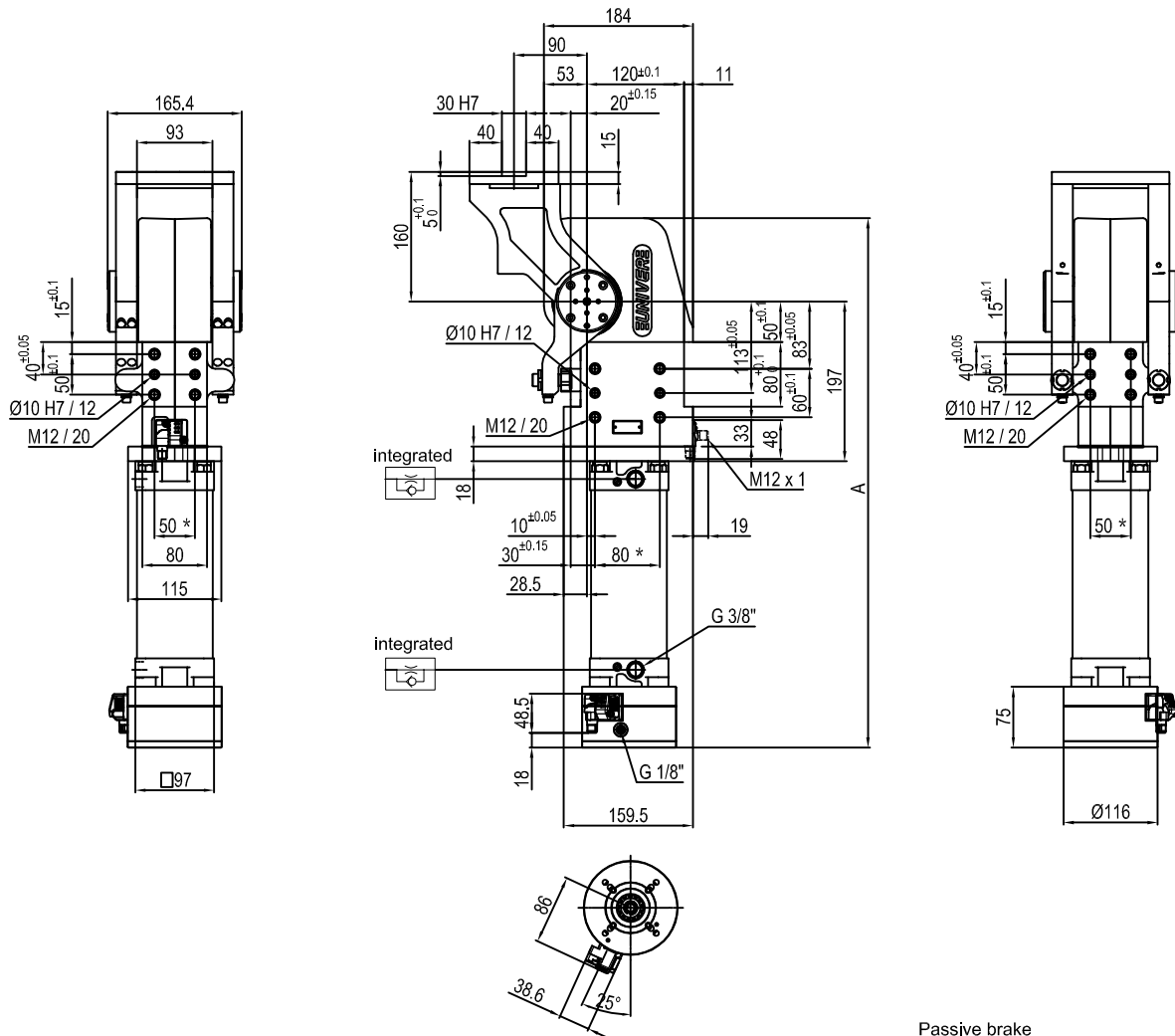

Pivot rotation in degrees	A
45°	574
60°	588
90°	619
120°	653.5

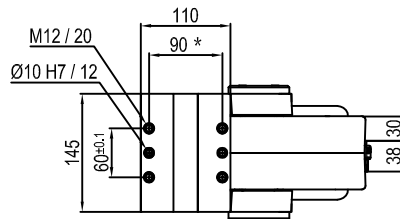

Passive brake

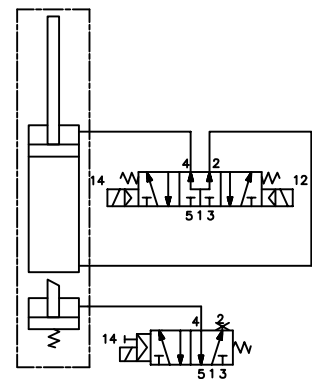

Size	Holding moment	Max. torque at the rotary table 0,55 MPa	Weight
075	6000 Nm	75 Nm	24 Kg

Min./Max. operating pressure: **0,4 / 0,6 MPa**
 Operating temperature: **5° + 45° C**
 Predetermine pivot rotation in degrees: **45° - 60° - 90° - 120°**
 Electronic sensor with M12 swivel connector that can be orientated at 0° or 90°
 Supply voltage: 10+30 V DC
 IP code: **IP 65**

* : TOLERANCE BETWEEN DOWEL HOLES ± 0.02, TO SCREW HOLES ± 0.1

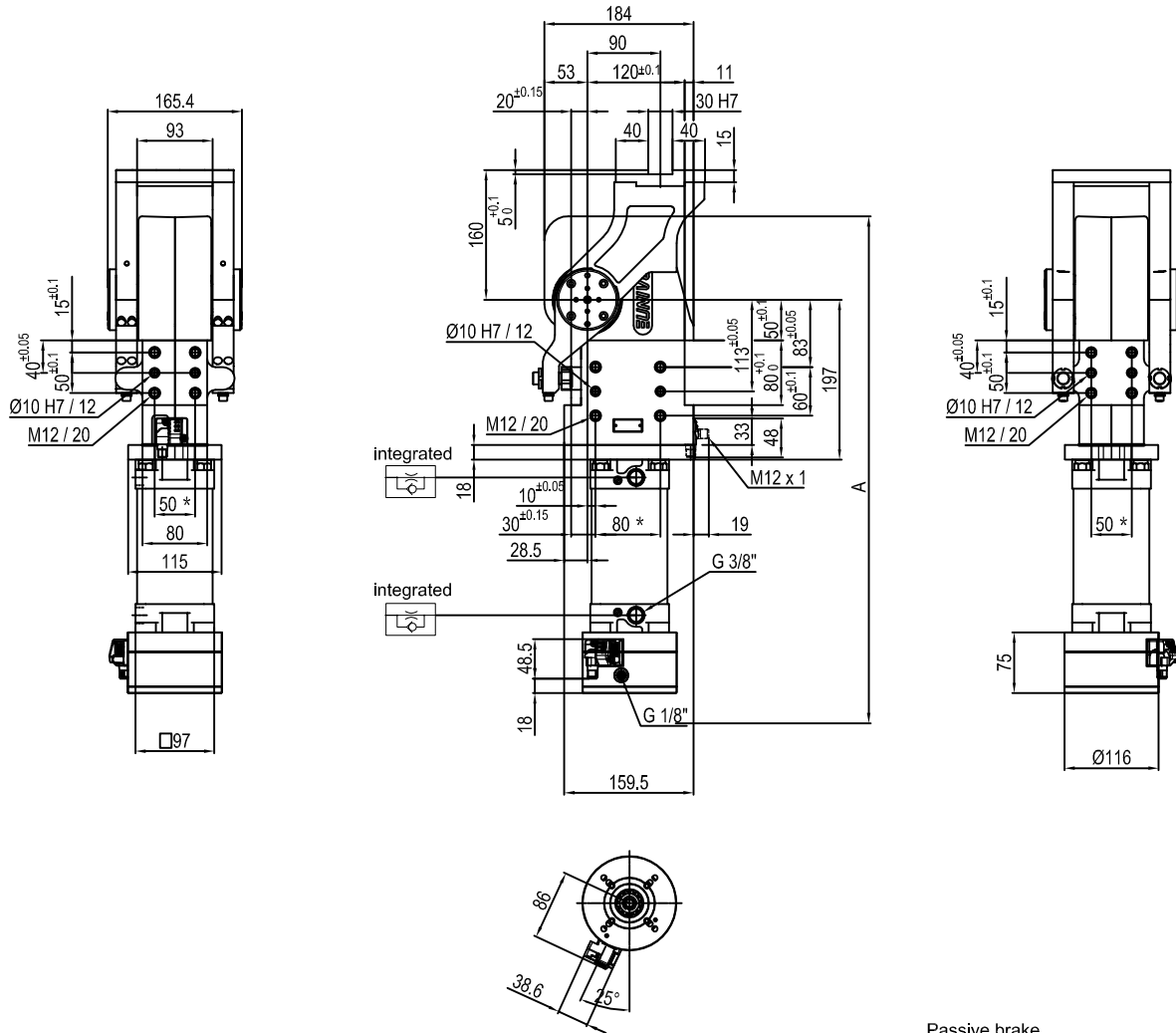

Pivot rotation in degrees	A
45°	574
60°	588

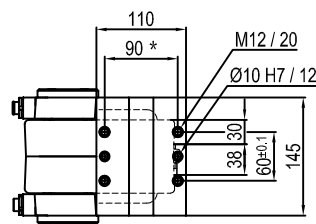

Passive brake

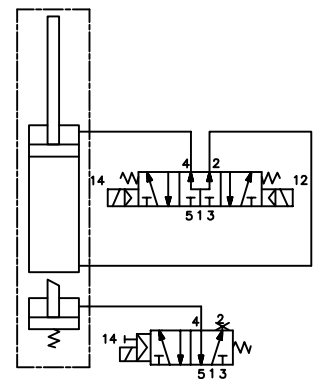

Size	Holding moment	Max. torque at the rotary table 0,55 MPa	Weight
075	6000 Nm	75 Nm	24 Kg

Min./Max. operating pressure: **0,4 / 0,6 MPa**
 Operating temperature: **5° + 45° C**
 Predetermine pivot rotation in degrees: **45° - 60°**
 Electronic sensor with M12 swivel connector that can be orientated at 0° or 90°
 Supply voltage: 10+30 V DC
 IP code: **IP 65**

* : TOLERANCE BETWEEN DOWEL HOLES ± 0.02, TO SCREW HOLES ± 0.1

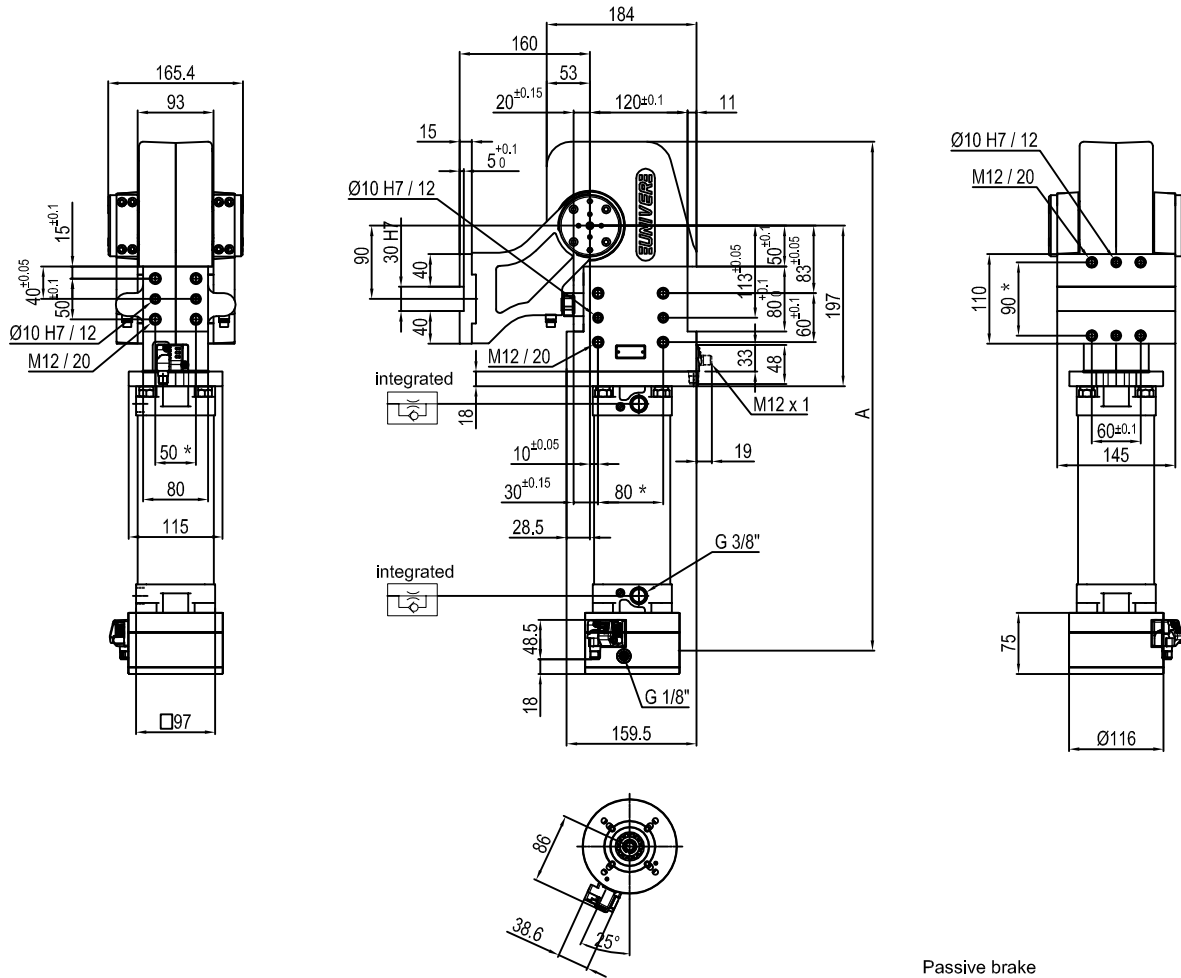

Pivot rotation in degrees	A
45°	574
60°	588
90°	619
120°	653.5

Size	Holding moment	Max. torque at the rotary table 0,55 MPa	Weight
075	6000 Nm	75 Nm	24 Kg

Min./Max. operating pressure: **0,4 / 0,6 MPa**
 Operating temperature: **5° + 45° C**
 Predetermine pivot rotation in degrees: **45° - 60° - 90° - 120°**
 Electronic sensor with M12 swivel connector that can be orientated at 0° or 90°
 Supply voltage: 10-30 V DC
 IP code: **IP 65**

* : TOLERANCE BETWEEN DOWEL HOLES ± 0.02, TO SCREW HOLES ± 0.1

Pneumatic power pivot

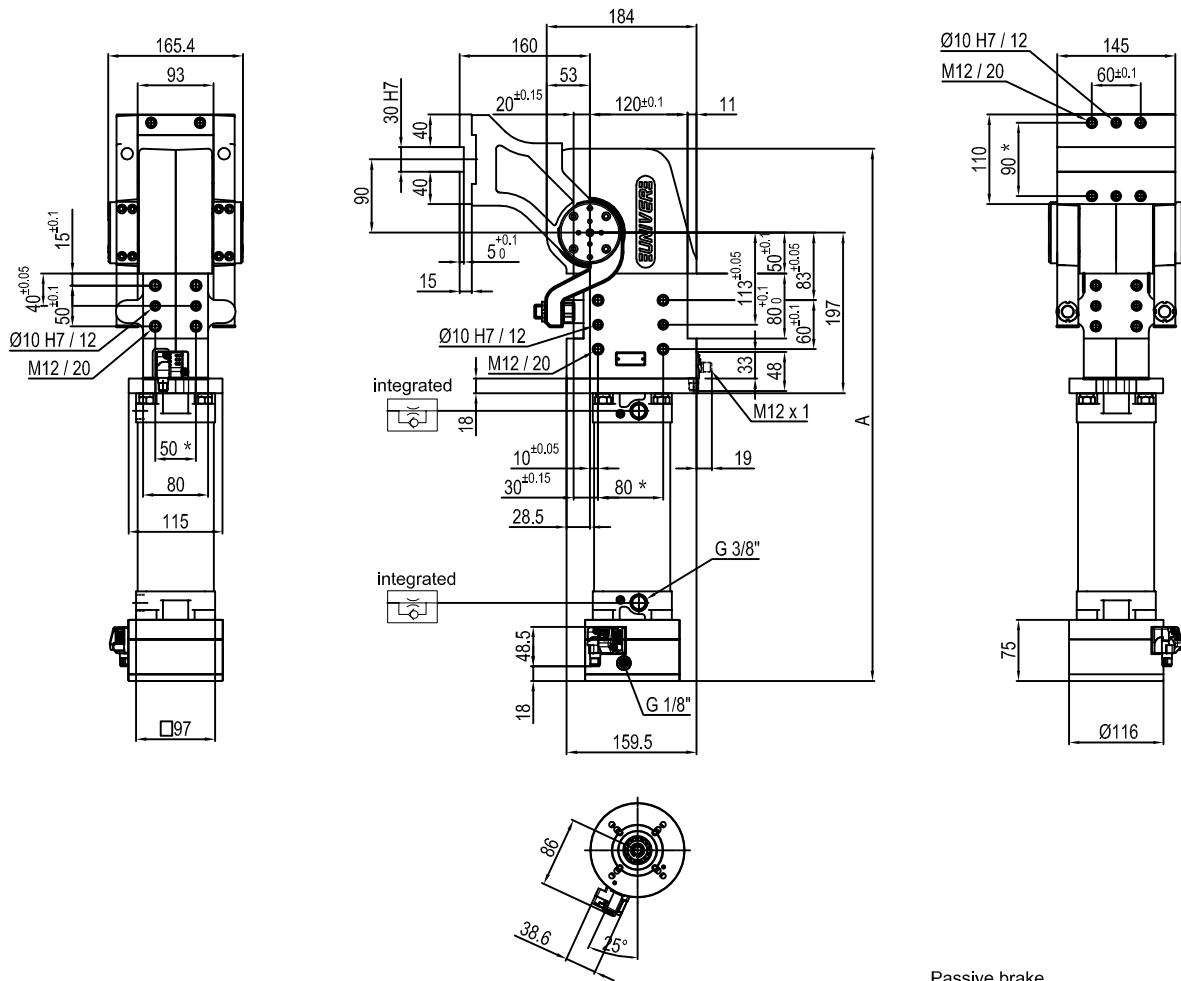

Pivot rotation in degrees	A
45°	574
60°	588
90°	619
120°	653.5

Passive brake

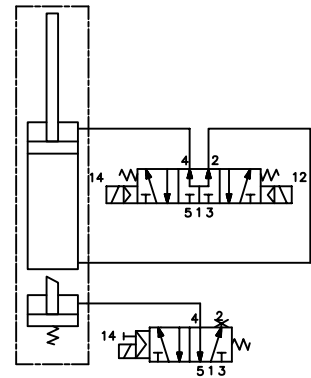

Size	Holding moment	Max. torque at the rotary table 0,55 MPa	Weight
075	6000 Nm	75 Nm	24 Kg

Min./Max. operating pressure: **0,4 / 0,6 MPa**
 Operating temperature: **5° ± 45° C**
 Predetermine pivot rotation in degrees: **45° - 60° - 90° - 120°**
 Electronic sensor with M12 swivel connector that can be orientated at 0° or 90°
 Supply voltage: 10+30 V DC
 IP code: **IP 65**

* : TOLERANCE BETWEEN DOWEL HOLES ± 0,02, TO SCREW HOLES ± 0,1

Subject to technical modifications without notice.

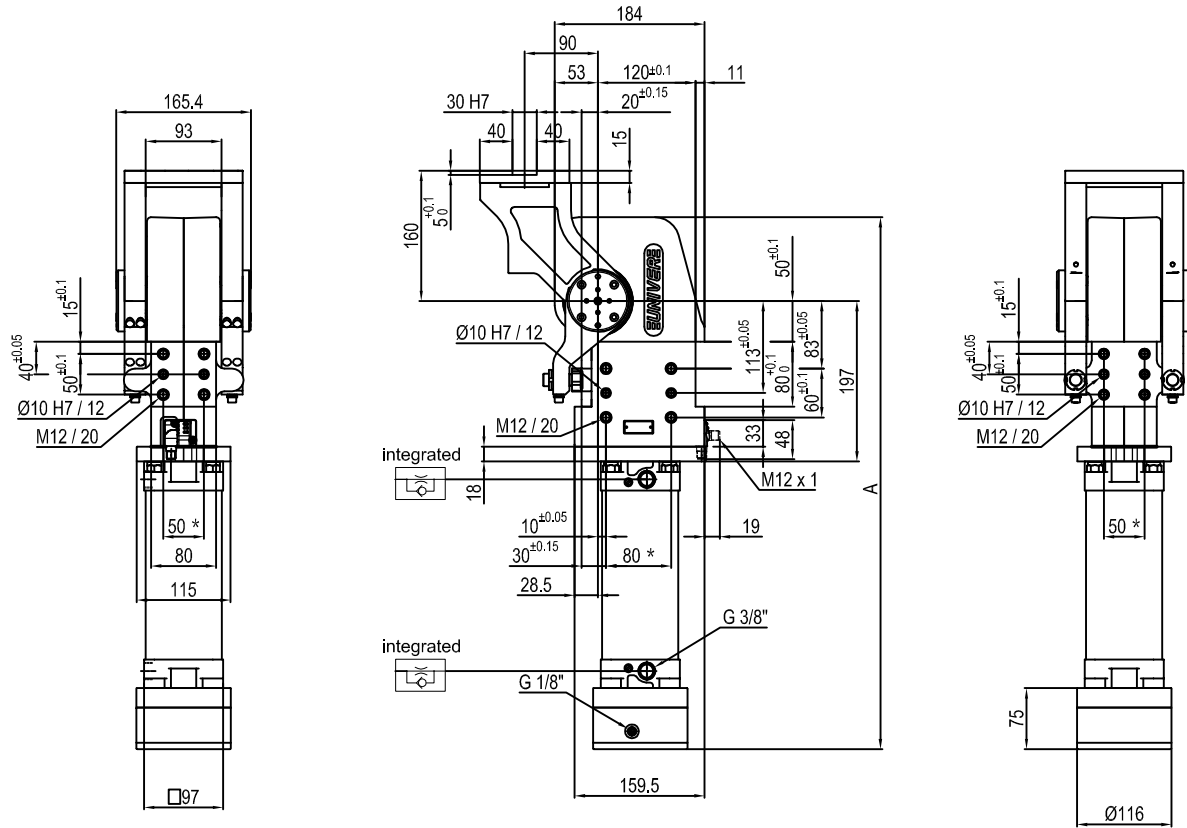

Pivot rotation in degrees	A
45°	574
60°	588
90°	619
120°	653.5

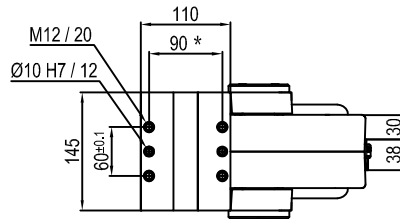

Passive brake

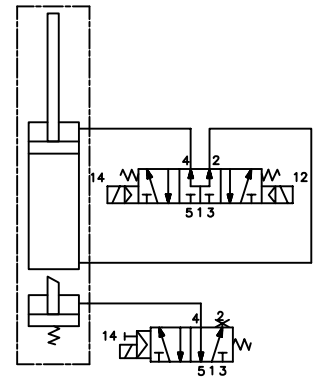

Size	Holding moment	Max. torque at the rotary table 0,55 MPa	Weight
075	6000 Nm	75 Nm	24 Kg

Min./Max. operating pressure: **0,4 / 0,6 MPa**
 Operating temperature: **5° + 45° C**
 Predetermine pivot rotation in degrees: **45° - 60° - 90° - 120°**
 Electronic sensor with M12 swivel connector that can be orientated at 0° or 90°
 Supply voltage: 10-30 V DC
 IP code: **IP 65**

* : TOLERANCE BETWEEN DOWEL HOLES ± 0.02, TO SCREW HOLES ± 0.1

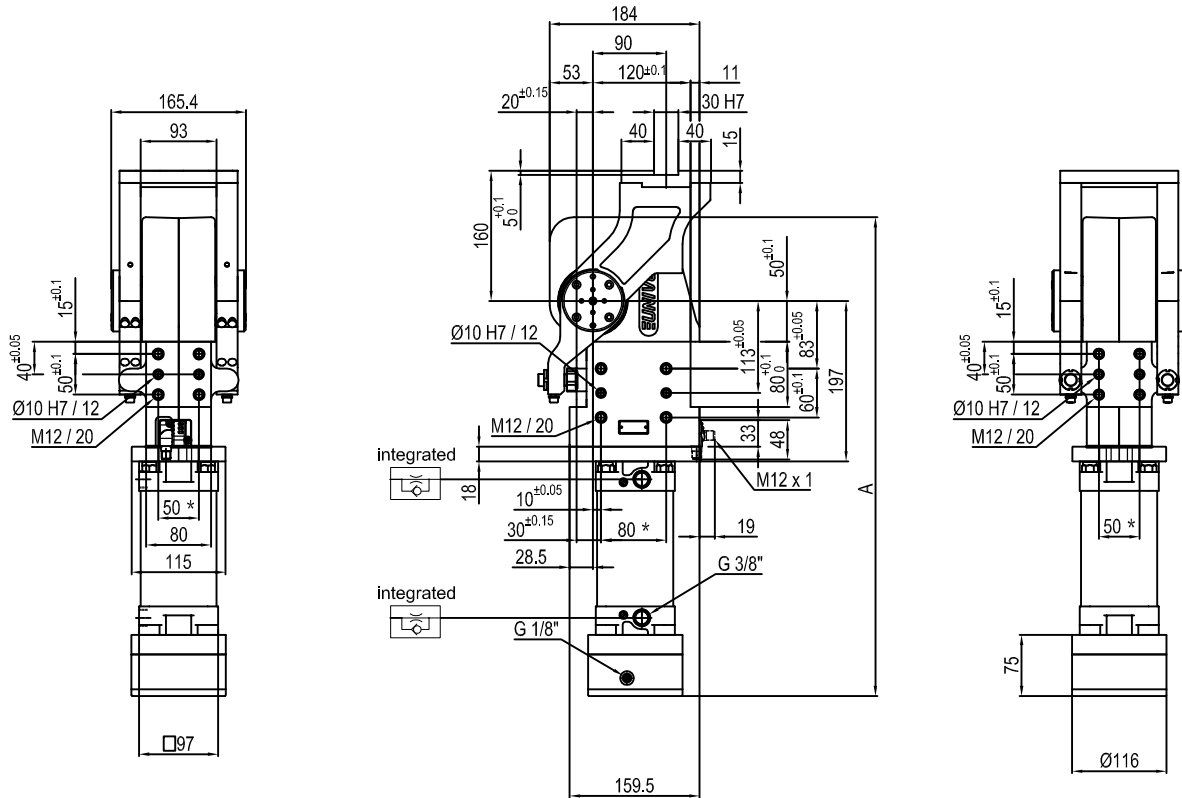

Pivot rotation in degrees	A
45°	574
60°	588

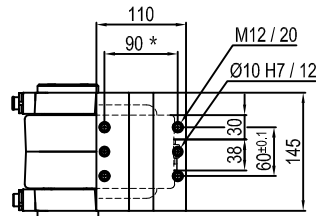

Passive brake

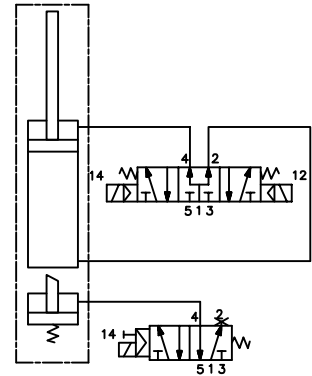

Size	Holding moment	Max. torque at the rotary table 0,55 MPa	Weight
075	6000 Nm	75 Nm	24 Kg

Min./Max. operating pressure: 0,4 / 0,6 MPa
 Operating temperature: 5° + 45° C
 Predetermine pivot rotation in degrees: 45° - 60°
 Electronic sensor with M12 swivel connector that can be orientated at 0° or 90°
 Supply voltage: 10÷30 V DC
 IP code: IP 65

* : TOLERANCE BETWEEN DOWEL HOLES ± 0.02, TO SCREW HOLES ± 0.1

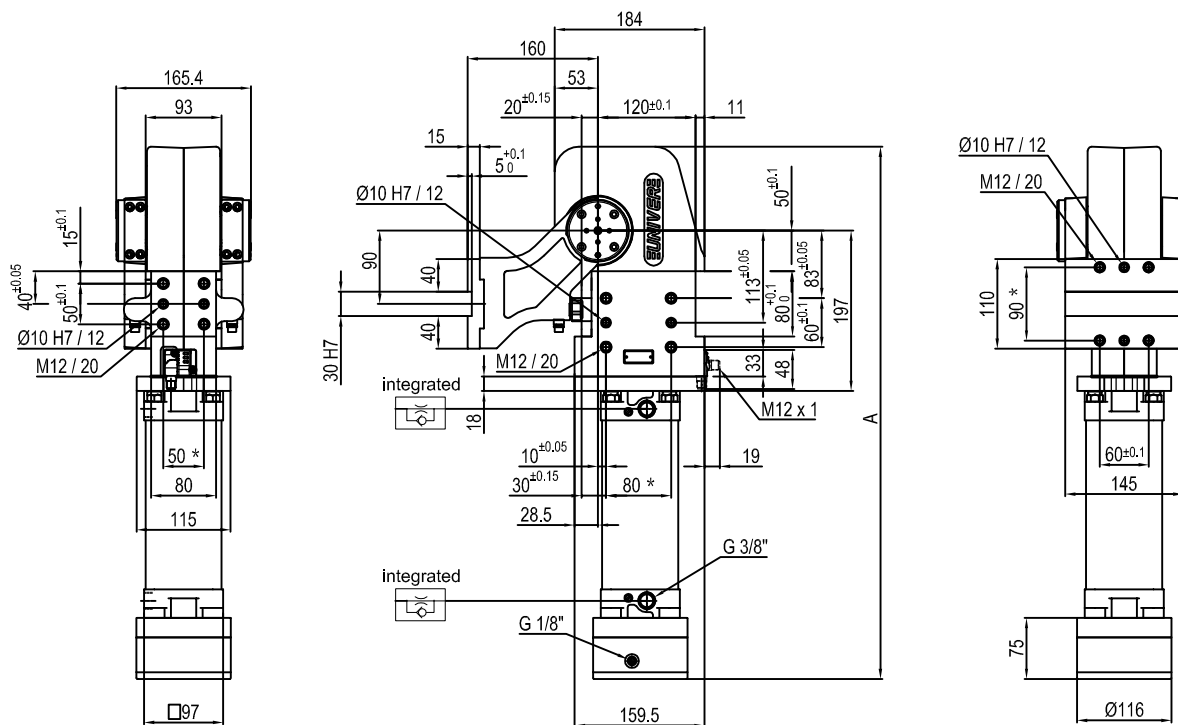

Pivot rotation in degrees	A
45°	574
60°	588
90°	619
120°	653.5

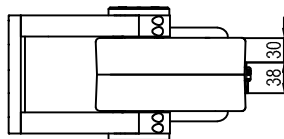

Passive brake

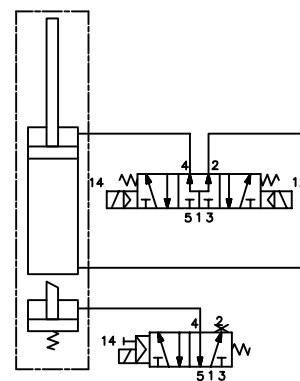

Size	Holding moment	Max. torque at the rotary table 0,55 MPa	Weight
075	6000 Nm	75 Nm	24 Kg

* : TOLERANCE BETWEEN DOWEL HOLES ± 0.02 , TO SCREW HOLES ± 0.1

Min./Max. operating pressure: **0,4 / 0,6 MPa**
 Operating temperature: **5° + 45° C**
 Predeterminate pivot rotation in degrees: **45° - 60° - 90° - 120°**
 Electronic sensor with M12 swivel connector that can be orientated at 0° or 90°
 Supply voltage: **10÷30 V DC**
 IP code: **IP 65**

Pneumatic power pivot

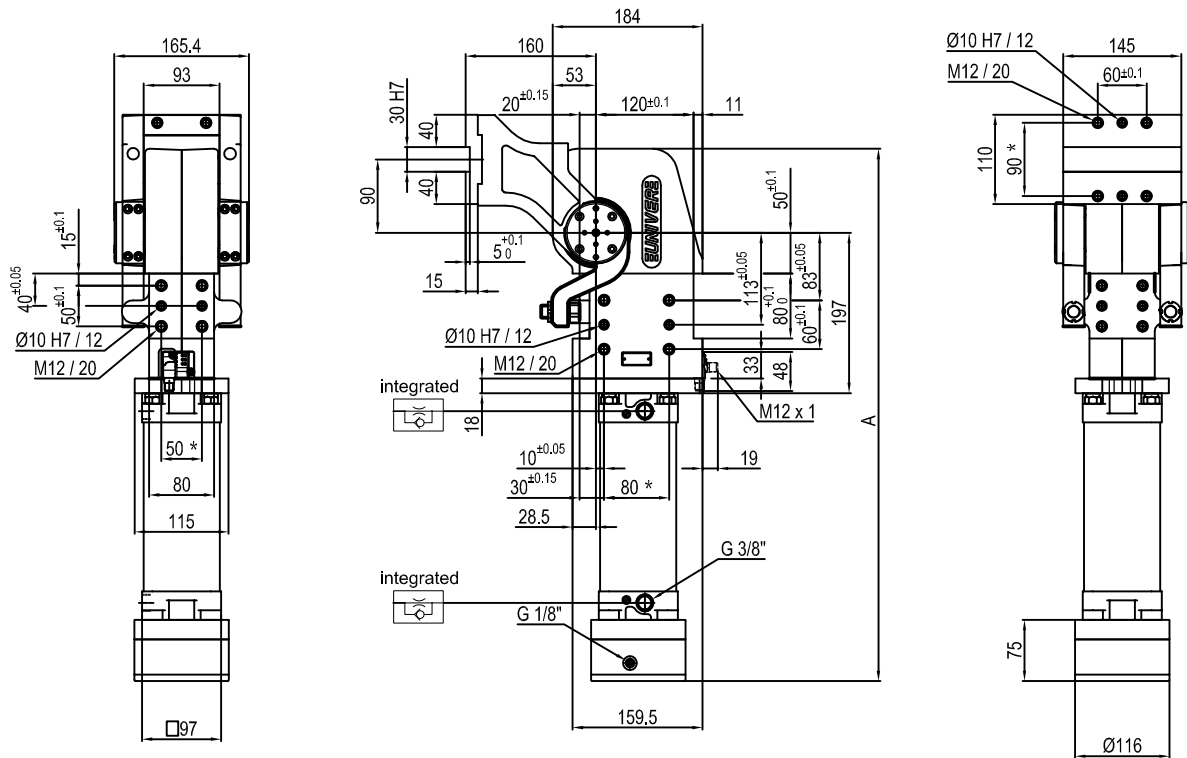

Pivot rotation in degrees	A
45°	574
60°	588
90°	619
120°	653.5

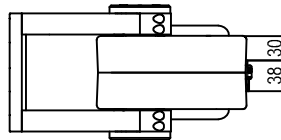

Passive brake

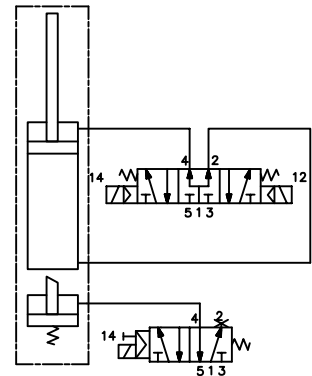

Size	Holding moment	Max. torque at the rotary table 0,55 MPa	Weight
075	6000 Nm	75 Nm	24 Kg

Min./Max. operating pressure: **0,4 / 0,6 MPa**
 Operating temperature: **5° + 45° C**
 Predetermine pivot rotation in degrees: **45° - 60° - 90° - 120°**
 Electronic sensor with M12 swivel connector that can be orientated at 0° or 90°
 Supply voltage: 10+30 V DC
 IP code: **IP 65**

* : TOLERANCE BETWEEN DOWEL HOLES ± 0.02, TO SCREW HOLES ± 0.1

Subject to technical modifications without notice.

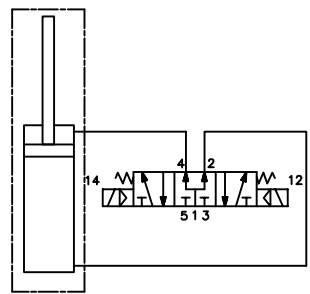
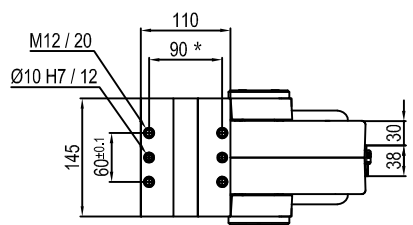
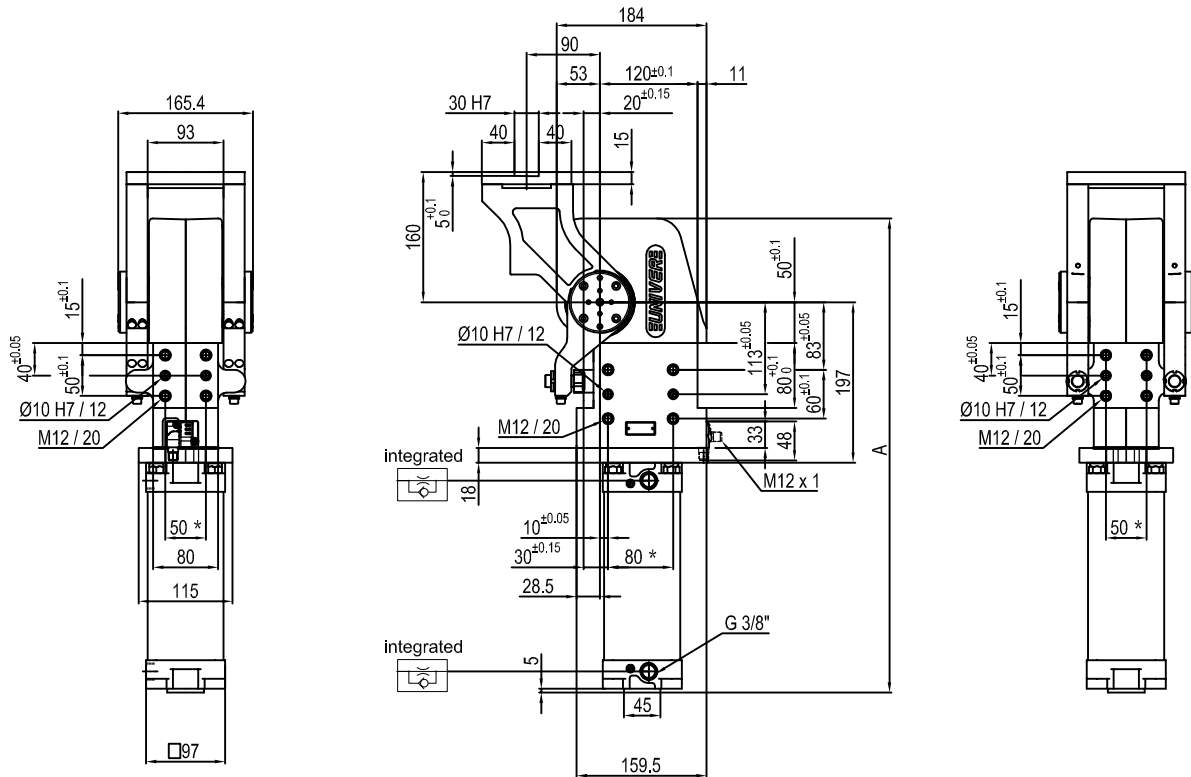

Pivot rotation in degrees	A
45°	503
60°	517
90°	548
120°	582.5

Size	Holding moment	Max. torque at the rotary table 0,55 MPa	Weight
075	6000 Nm	75 Nm	18 Kg

Min./Max. operating pressure: **0,4 / 0,6 MPa**
 Operating temperature: **5° + 45° C**
 Predetermine pivot rotation in degrees: **45° - 60° - 90° - 120°**
 Electronic sensor with M12 swivel connector that can be orientated at 0° or 90°
 Supply voltage: 10-30 V DC
 IP code: **IP 65**

* : TOLERANCE BETWEEN DOWEL HOLES ± 0.02, TO SCREW HOLES ± 0.1

Subject to technical modifications without notice.

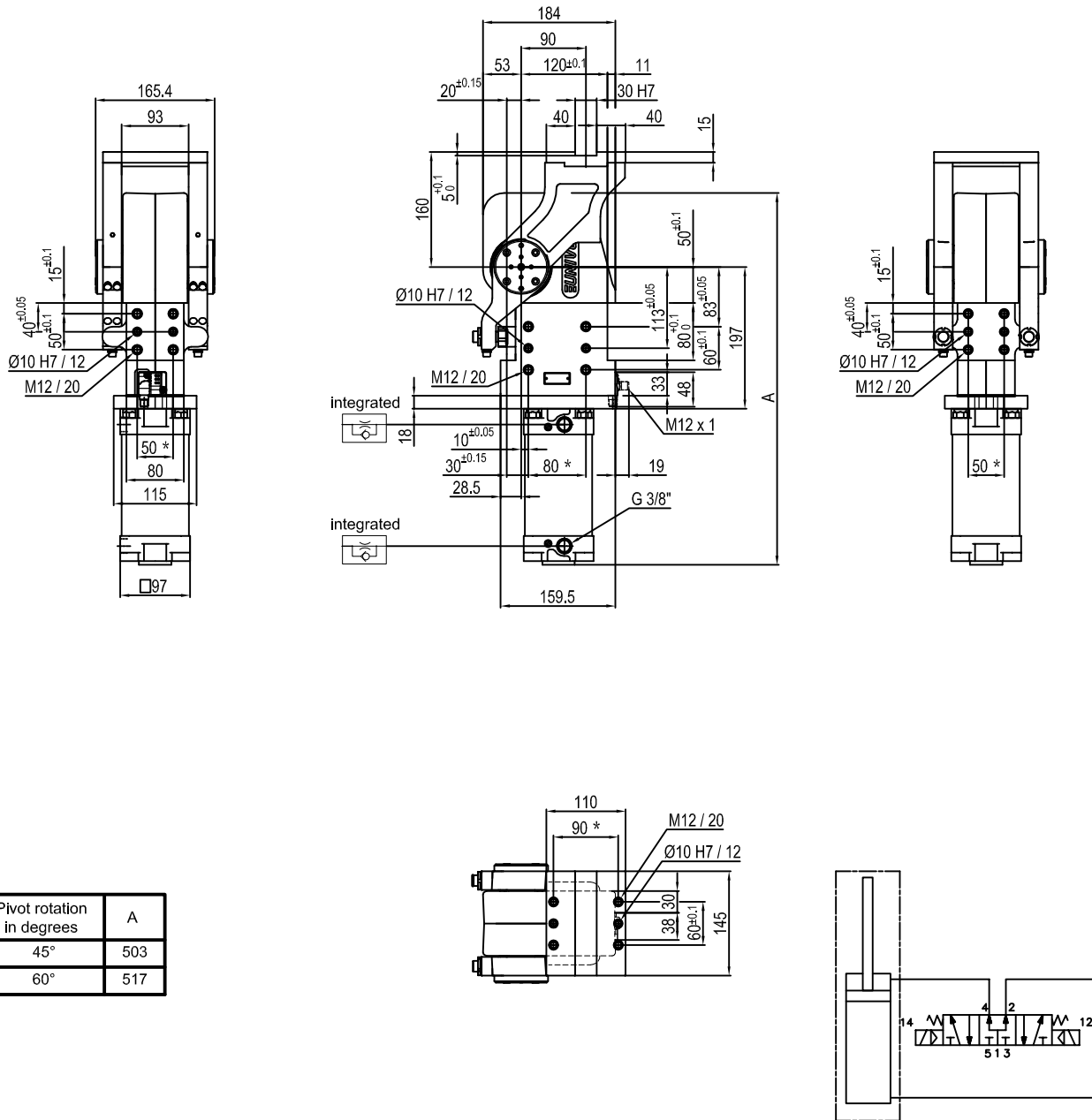

Pivot rotation in degrees	A
45°	503
60°	517

Size	Holding moment	Max. torque at the rotary table 0,55 MPa	Weight
075	6000 Nm	75 Nm	18 Kg

* : TOLERANCE BETWEEN DOWEL HOLES ± 0.02, TO SCREW HOLES ± 0.1

Min./Max. operating pressure: **0,4 / 0,6 MPa**
 Operating temperature: **5° + 45° C**
 Predeterminate pivot rotation in degrees: **45° - 60°**
 Electronic sensor with M12 swivel connector that can be orientated at 0° or 90°
 Supply voltage: 10+30 V DC
 IP code: **IP 65**

Subject to technical modifications without notice.

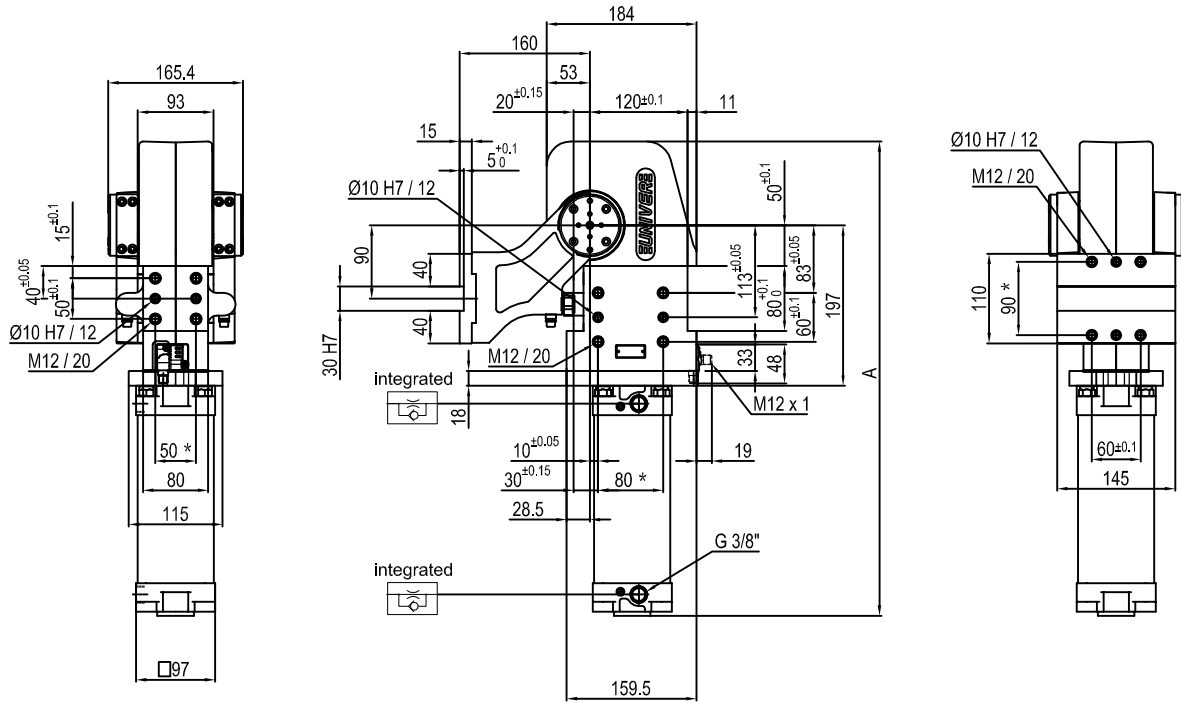

Pivot rotation in degrees	A
45°	503
60°	517
90°	548
120°	582.5

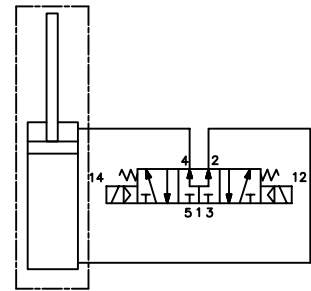
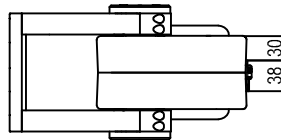

Size	Holding moment	Max. torque at the rotary table 0,55 MPa	Weight
075	6000 Nm	75 Nm	18 Kg

Min./Max. operating pressure: **0,4 / 0,6 MPa**
 Operating temperature: **5° + 45° C**
 Predeterminate pivot rotation in degrees: **45° - 60° - 90° - 120°**
 Electronic sensor with M12 swivel connector that can be orientated at 0° or 90°
 Supply voltage: 10÷30 V DC
 IP code: **IP 65**

* : TOLERANCE BETWEEN DOWEL HOLES ± 0.02, TO SCREW HOLES ± 0.1

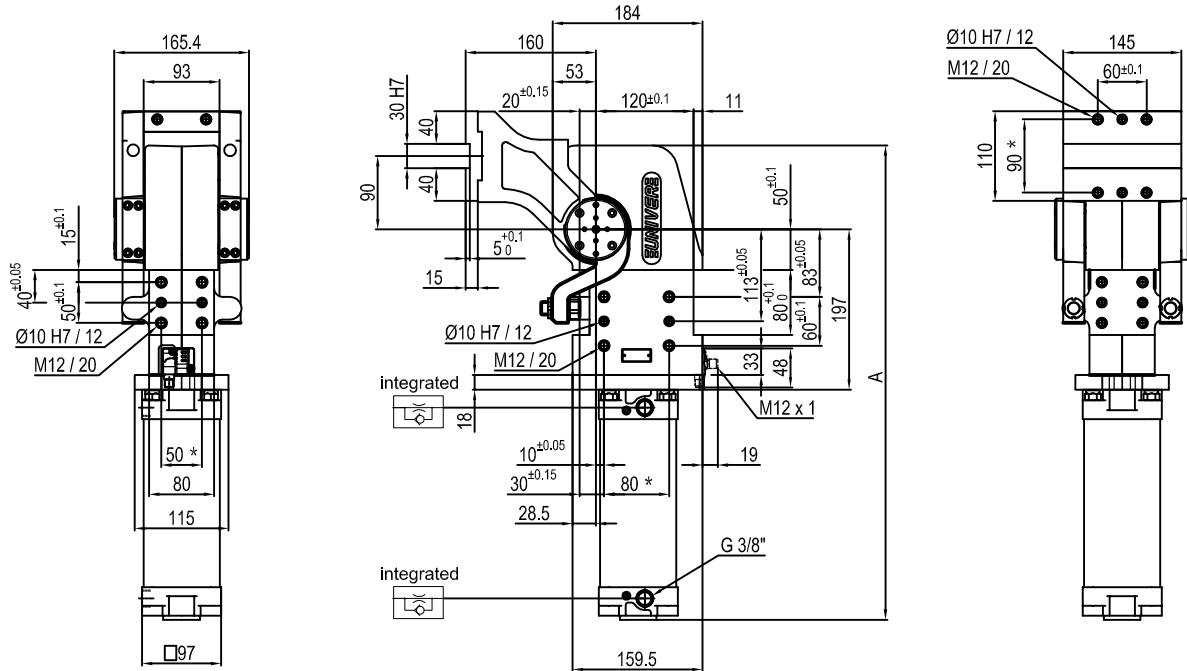

Pivot rotation in degrees	A
45°	503
60°	517
90°	548
120°	582.5

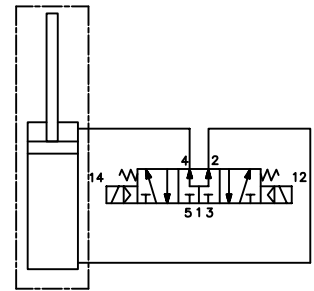
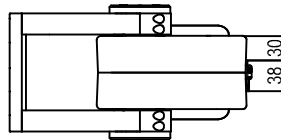

Size	Holding moment	Max. torque at the rotary table 0,55 MPa	Weight
075	6000 Nm	75 Nm	18 Kg

Min./Max. operating pressure: **0,4 / 0,6 MPa**
 Operating temperature: **5° + 45° C**
 Predetermine pivot rotation in degrees: **45° - 60° - 90° - 120°**
 Electronic sensor with M12 swivel connector that can be orientated at 0° or 90°
 Supply voltage: 10+30 V DC
 IP code: **IP 65**

* : TOLERANCE BETWEEN DOWEL HOLES ± 0.02, TO SCREW HOLES ± 0.1

Subject to technical modifications without notice.