

# LAGP600

Pneumatic power pivot



L	A	G	P	6	0	0	V	E	0	9	0	B	C	
1	2	3			4	5	6		7	8	9			

<b>1 Series</b>	<b>2 Version</b>	<b>3 Size</b>
-----------------	------------------	---------------

**LAG** = Power pivot with predeterminate pivot rotation angles

**P** = Pneumatic-standard

**600** = Ø 200 mm cylinder

<b>4 Table position</b>	<b>5 Sensor</b>	<b>6 Pivot rotation angles</b>
-------------------------	-----------------	--------------------------------

**V** = Vertical 180°  
**O** = Horizontal 90°  
**Z** = Vertical, mirror of V position  
 Max opening angle 120°  
**P** = Horizontal, mirror of O position  
 Max opening angle 60°

**E** = Electronic sensor with M12 swivel connector  
**A** = Electronic sensor with M12 swivel connector + electronic sensor for brake condition detection

**120** = 120°  
**090** = 90°  
**060** = 60°  
**045** = 45°

<b>7 Brake system</b>	<b>8 Valve</b>	<b>9 Connections</b>
-----------------------	----------------	----------------------

**B** = With brake  
**W** = Without brake

**C** = Integrated valve for cycle time optimization

**\_** = If not specified, on the left side (sensor left side)  
**D** = Right side (sensor right side)  
**F** = Front side (in front of the sensor)  
**P** = Rear side (same side as sensor)

## Pneumatic power pivot

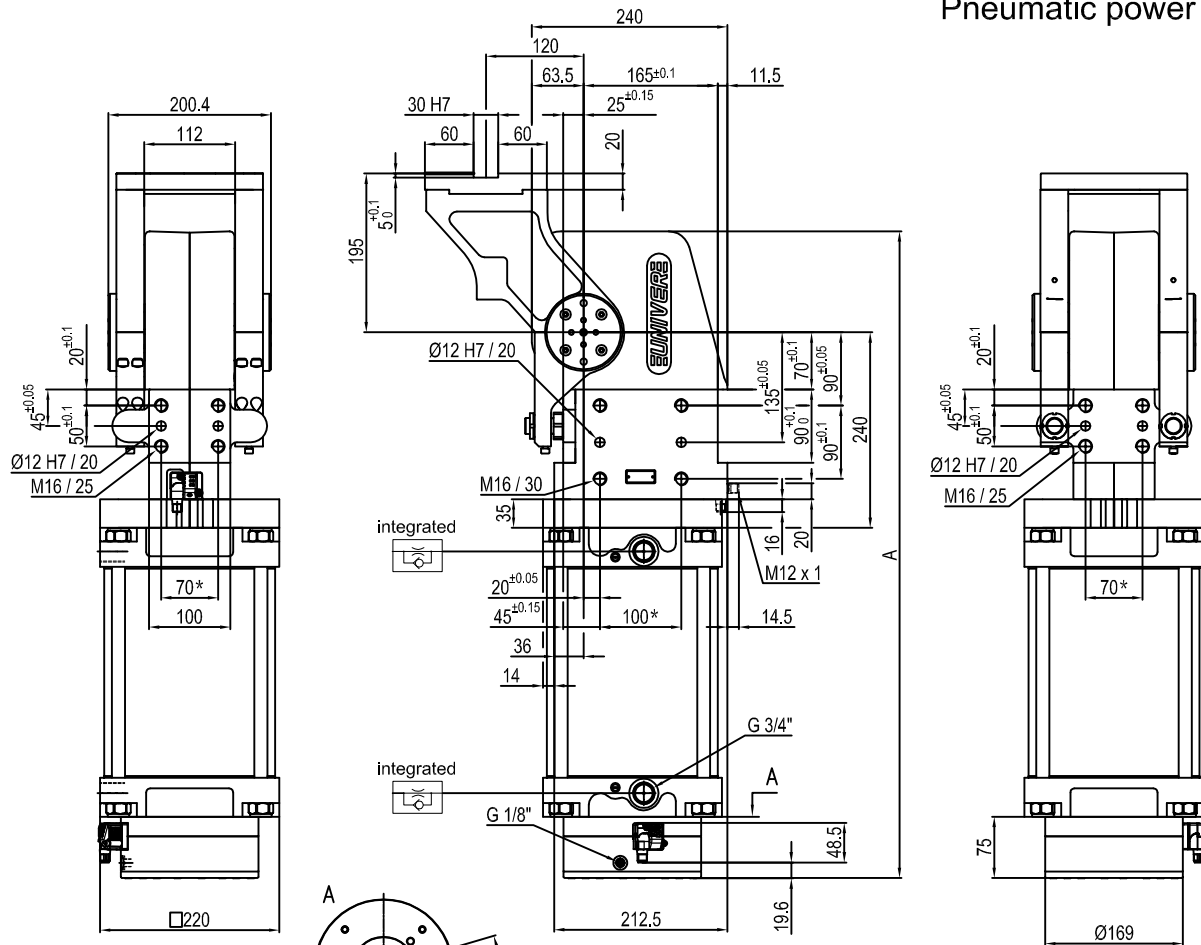

Pivot rotation in degrees	A
45°	702
60°	718
90°	755
120°	794

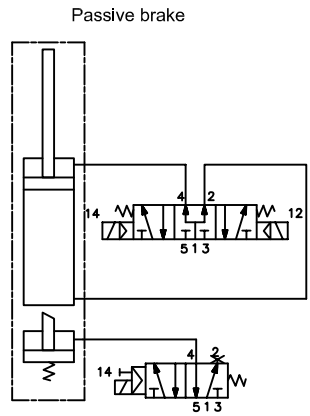
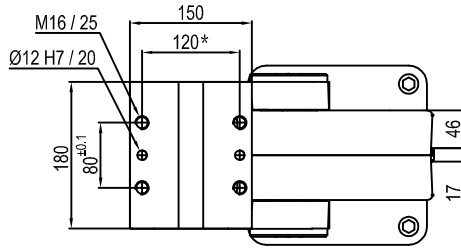

Size	Holding moment	Max. torque at the rotary table 0,55 MPa	Weight
600	8000 Nm	600 Nm	59.7 Kg

Min./Max. operating pressure: **0,4 / 0,6 MPa**  
 Operating temperature: **5° + 45° C**  
 Predetermine pivot rotation in degrees: **45° - 60° - 90° - 120°**  
 Electronic sensor with M12 swivel connector that can be orientated at 0° or 90°  
 Supply voltage: 10+30 Vdc  
 IP code: **IP 65**

\* : TOLERANCE BETWEEN DOWEL HOLES ± 0.02, TO SCREW HOLES ± 0.1

## Pneumatic power pivot

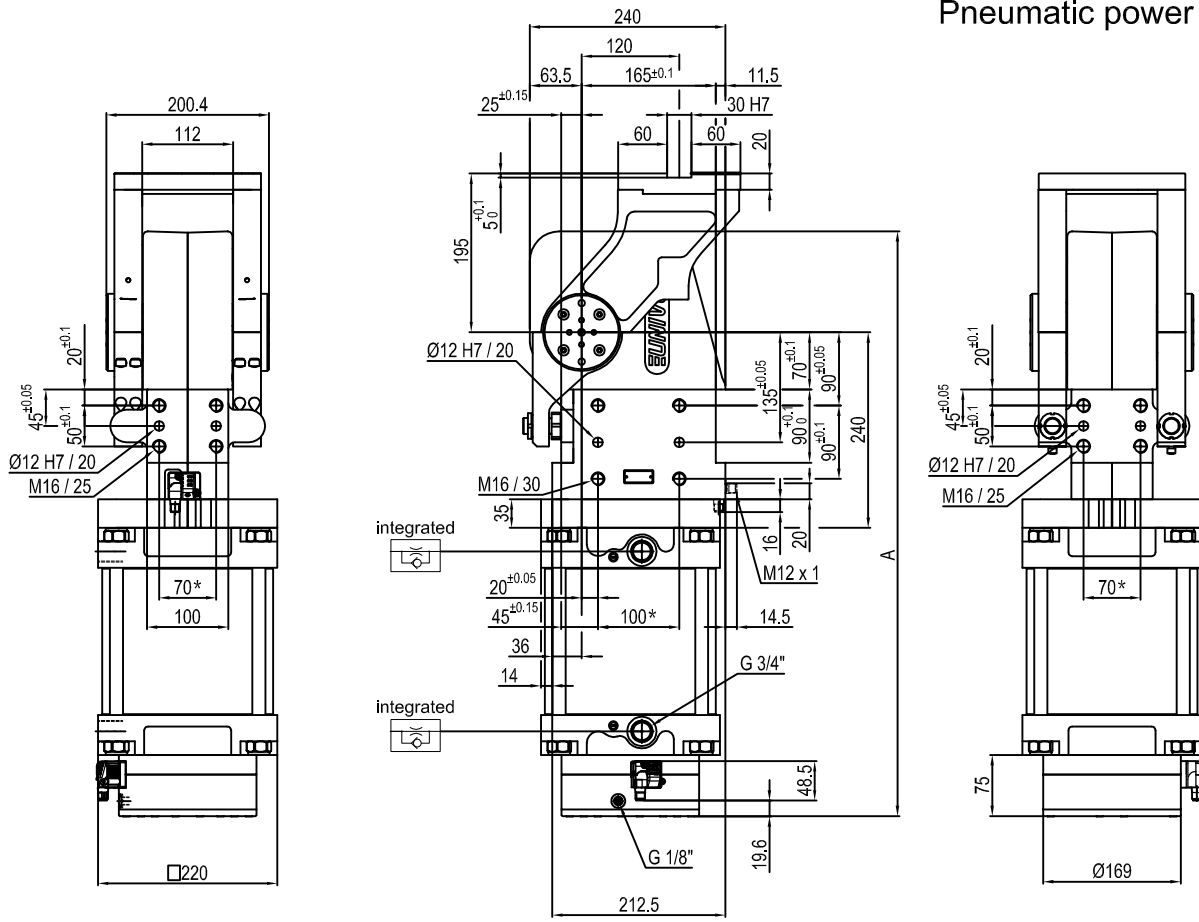

Pivot rotation in degrees	A
45°	702
60°	718

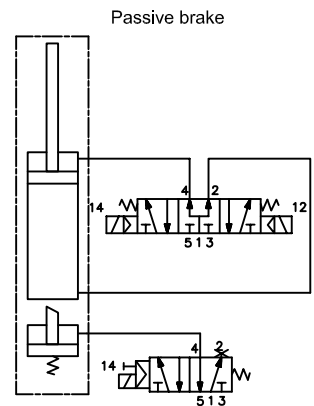
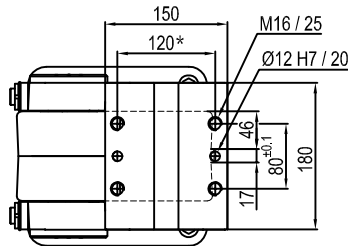
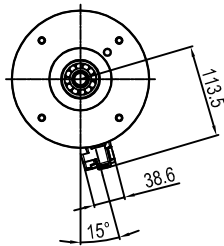

Size	Holding moment	Max. torque at the rotary table 0,55 MPa	Weight
600	8000 Nm	600 Nm	59,7 Kg

Min./Max. operating pressure: **0,4 / 0,6 MPa**  
 Operating temperature: **5° + 45° C**  
 Predeterminate pivot rotation in degrees: **45° - 60°**  
 Electronic sensor with M12 swivel connector that can be orientated at 0° or 90°  
 Supply voltage: 10±30 Vdc  
 IP code: **IP 65**

\* : TOLERANCE BETWEEN DOWEL HOLES ± 0.02, TO SCREW HOLES ± 0.1

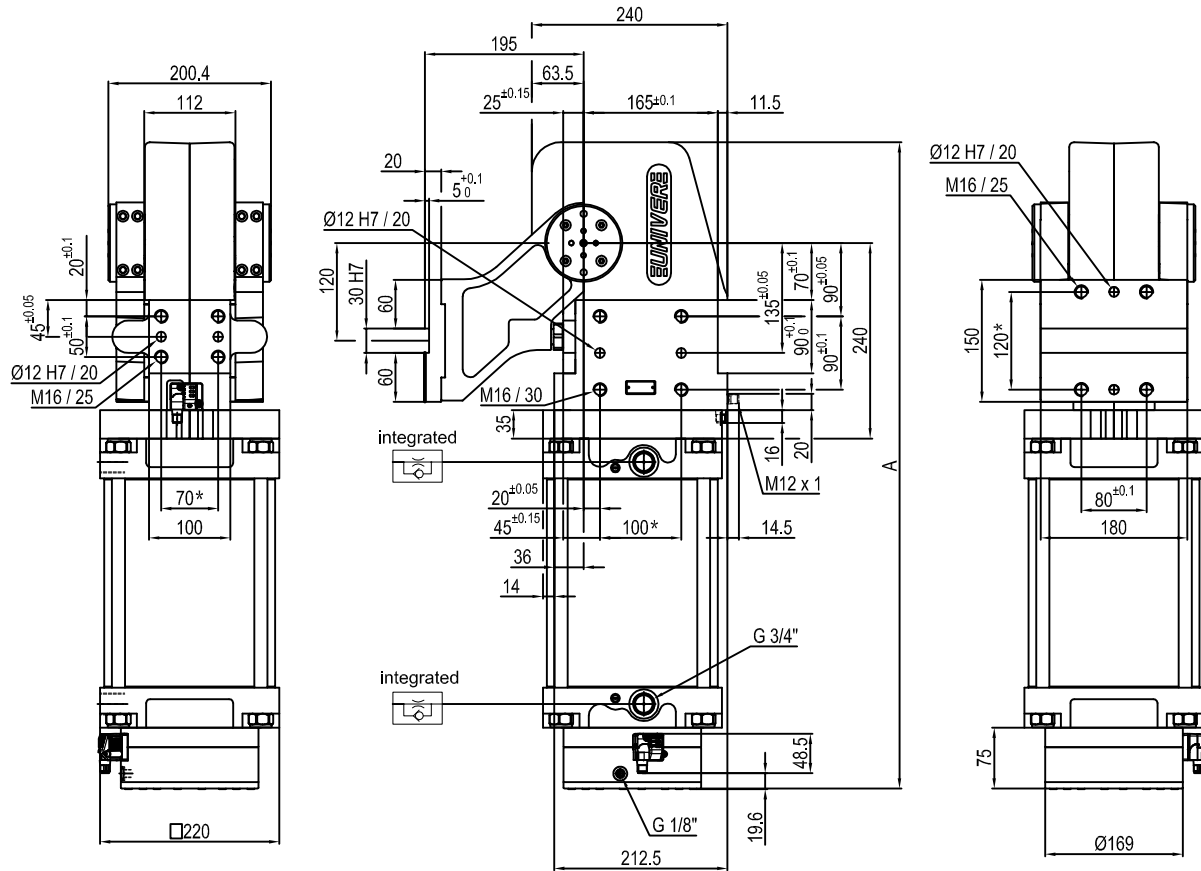

Pivot rotation in degrees	A
45°	702
60°	718
90°	755
120°	794

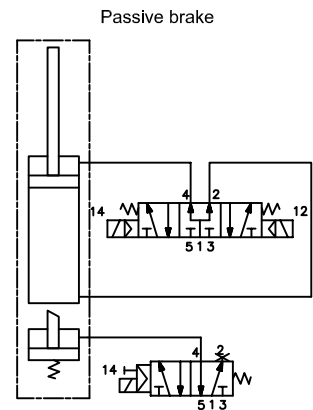
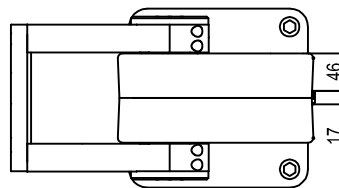
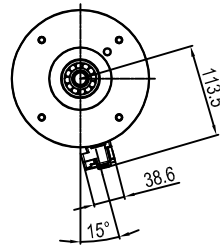

Size	Holding moment	Max. torque at the rotary table 0,55 MPa	Weight
600	8000 Nm	600 Nm	59,7 Kg

Min./Max. operating pressure: 0,4 / 0,6 MPa

Operating temperature: 5° + 45° C

Predetermine pivot rotation in degrees: 45° - 60° - 90° - 120°

Electronic sensor with M12 swivel connector that can be orientated at 0° or 90°

Supply voltage: 10+30 Vdc

IP code: IP 65

\* : TOLERANCE BETWEEN DOWEL HOLES ± 0.02, TO SCREW HOLES ± 0.1

## Pneumatic power pivot

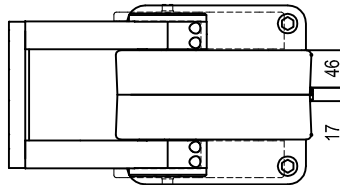
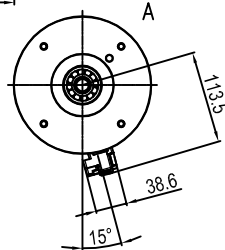
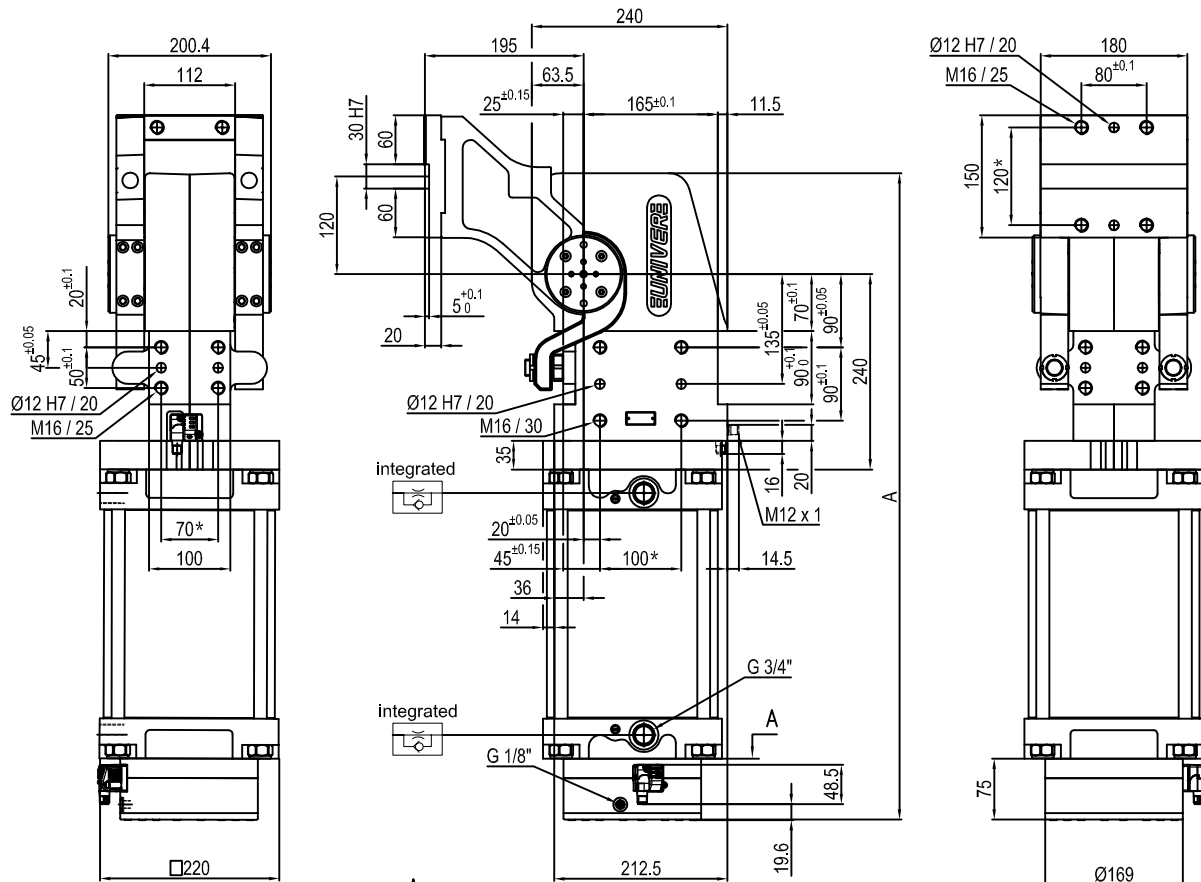

Pivot rotation in degrees	A
45°	702
60°	718
90°	755
120°	794

Passive brake

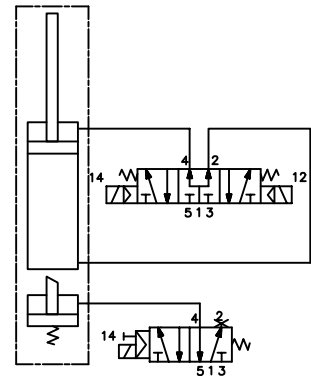

Size	Holding moment	Max. torque at the rotary table 0,55 MPa	Weight
600	8000 Nm	600 Nm	59.7Kg

Min./Max. operating pressure: **0,4 / 0,6 MPa**

Operating temperature: **5° + 45° C**

Predetermine pivot rotation in degrees: **45° - 60° - 90° - 120°**

Electronic sensor with M12 swivel connector that can be orientated at 0° or 90°

Supply voltage: 10+30 Vdc

IP code: **IP 65**

\* : TOLERANCE BETWEEN DOWEL HOLES ± 0.02, TO SCREW HOLES ± 0.1

## UNIVERSAL Pneumatic power pivot

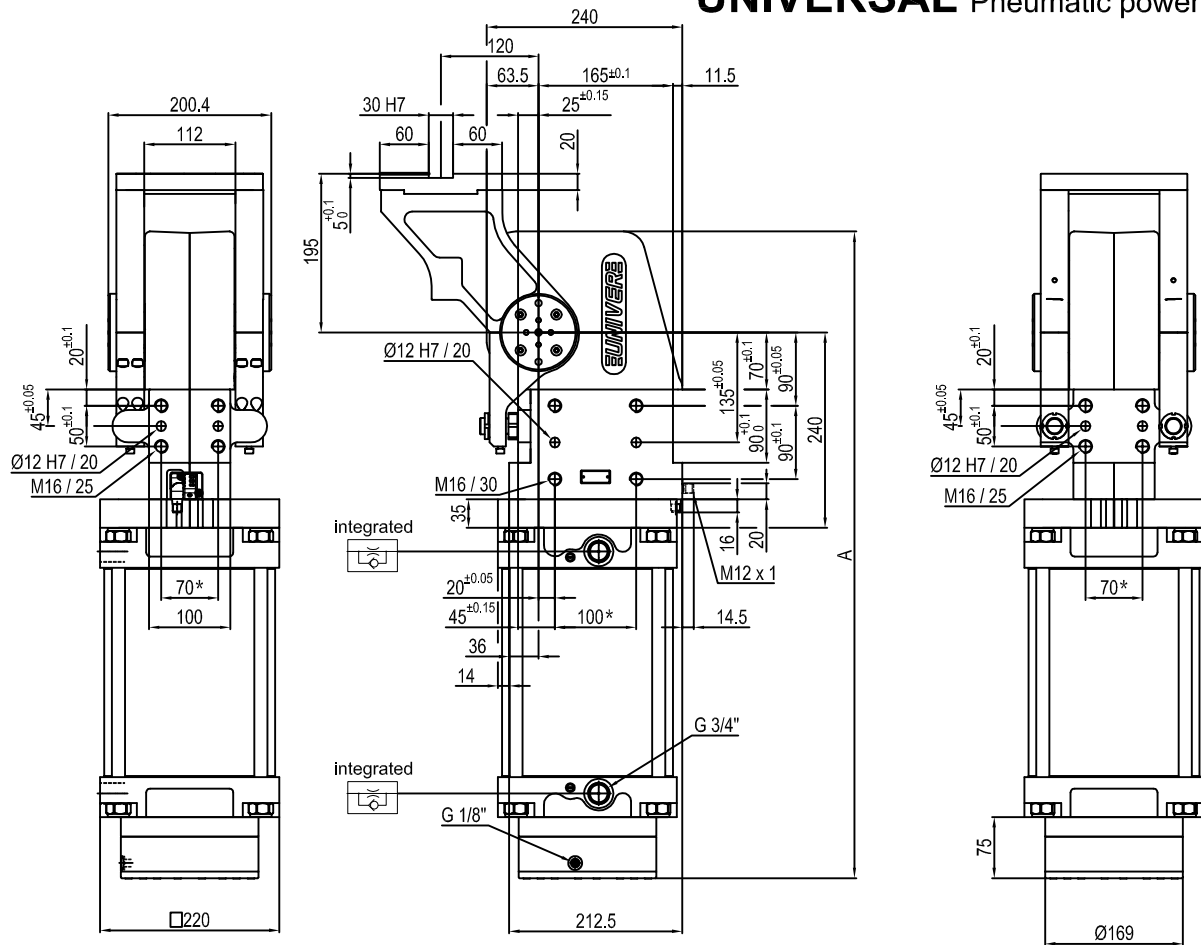

Pivot rotation in degrees	A
45°	702
60°	718
90°	755
120°	794

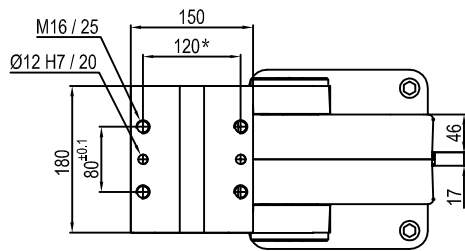

Passive brake

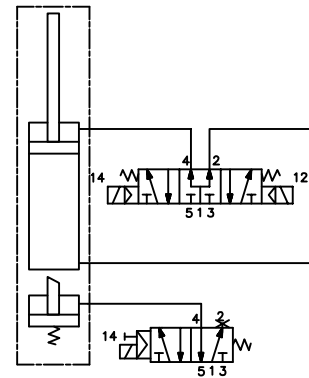

Size	Holding moment	Max. torque at the rotary table 0,55 MPa	Weight
600	8000 Nm	600 Nm	59.7 Kg

Min./Max. operating pressure: **0,4 / 0,6 MPa**

Operating temperature: **5° + 45° C**

Predetermine pivot rotation in degrees: **45° - 60° - 90° - 120°**

Electronic sensor with M12 swivel connector that can be orientated at 0° or 90°

Supply voltage: 10÷30 Vdc

IP code: **IP 65**

\* : TOLERANCE BETWEEN DOWEL HOLES ± 0.02, TO SCREW HOLES ± 0.1

Subject to technical modifications without notice.

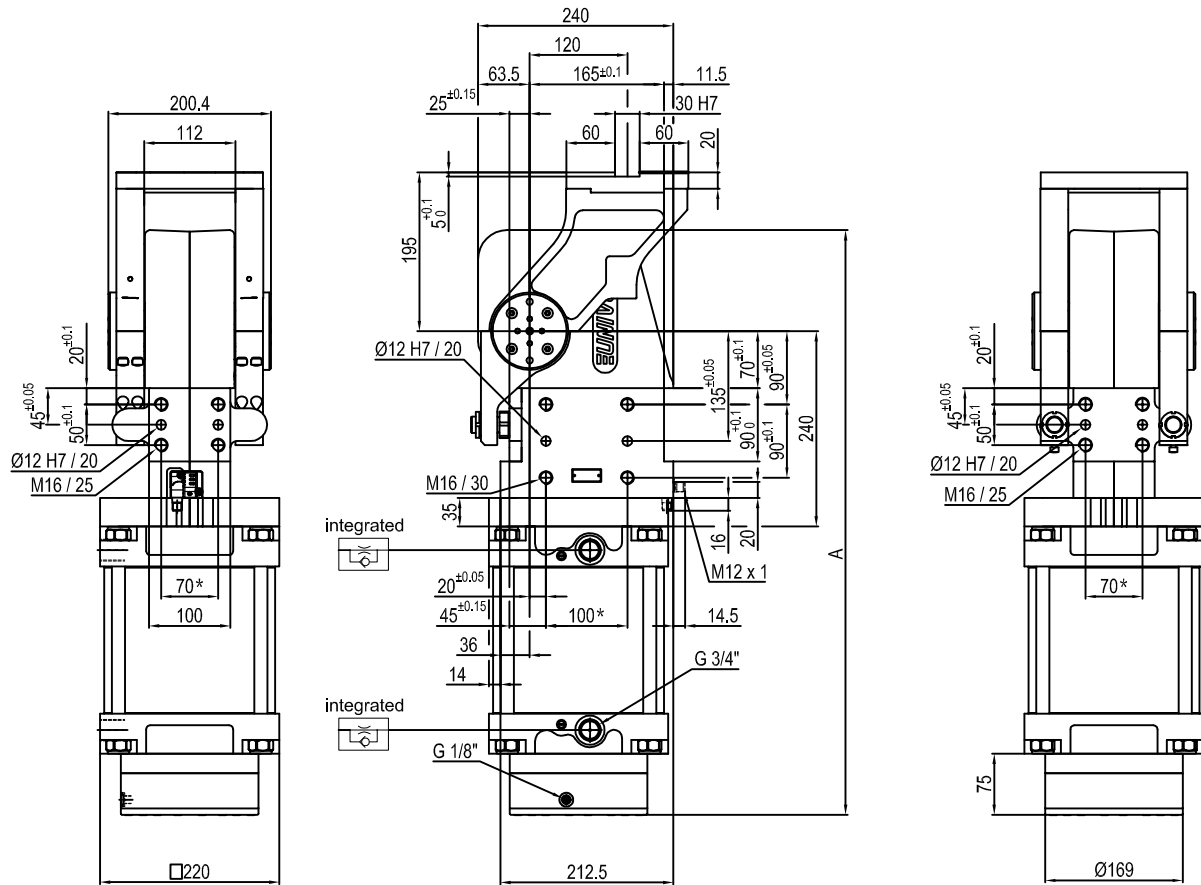

Pivot rotation in degrees	A
45°	702
60°	718

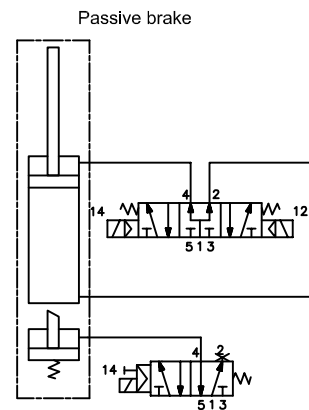
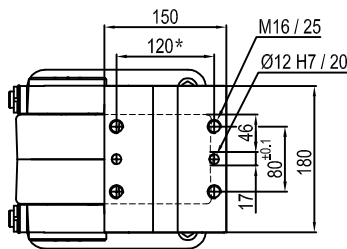

Size	Holding moment	Max. torque at the rotary table 0,55 MPa	Weight
600	8000 Nm	600 Nm	59.7 Kg

Min./Max. operating pressure: 0,4 / 0,6 MPa

Operating temperature: 5° + 45° C

Predetermine pivot rotation in degrees: 45° - 60°

Electronic sensor with M12 swivel connector that can be orientated at 0° or 90°

Supply voltage: 10÷30 Vdc

IP code: IP 65

\* : TOLERANCE BETWEEN DOWEL HOLES ± 0.02, TO SCREW HOLES ± 0.1

## Pneumatic power pivot

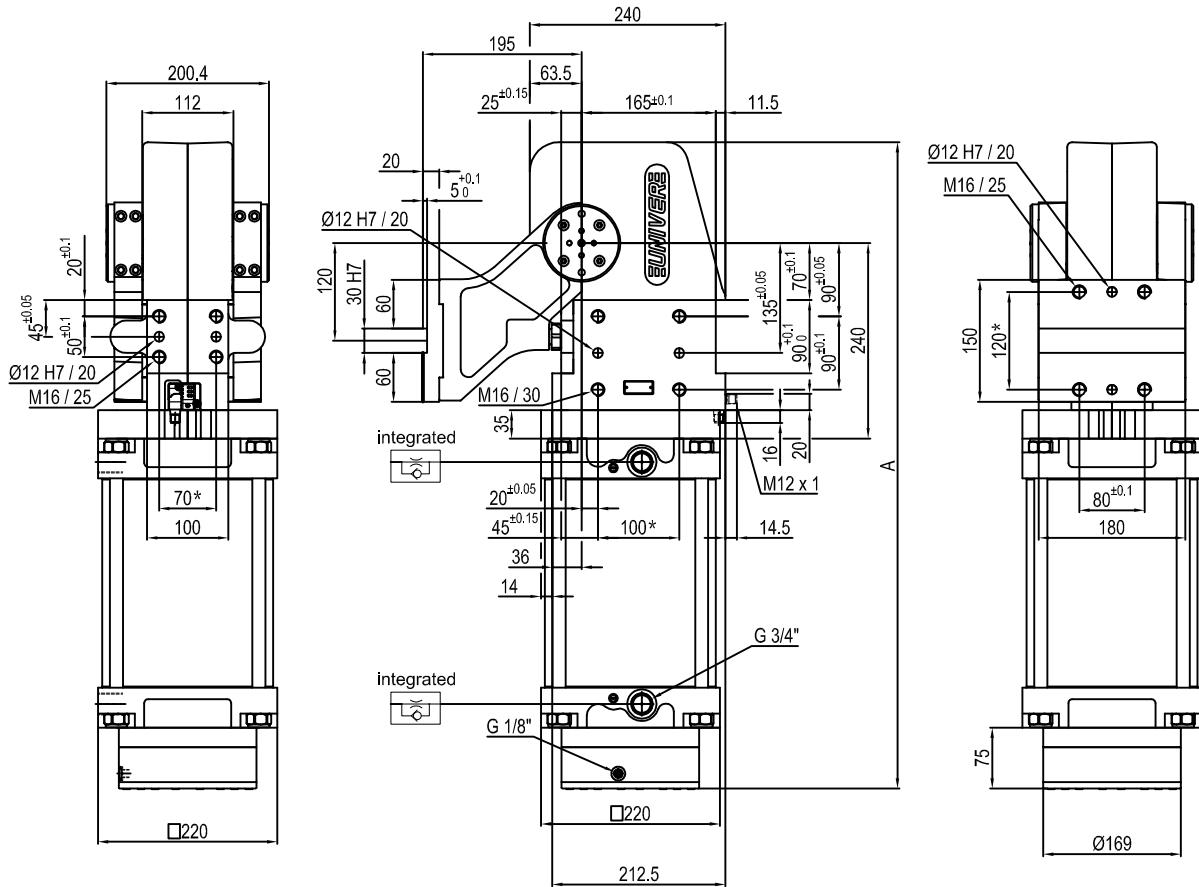

Pivot rotation in degrees	A
45°	702
60°	718
90°	755
120°	794

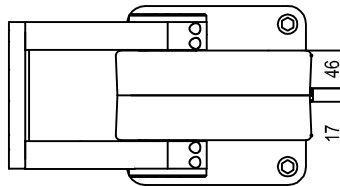

Passive brake

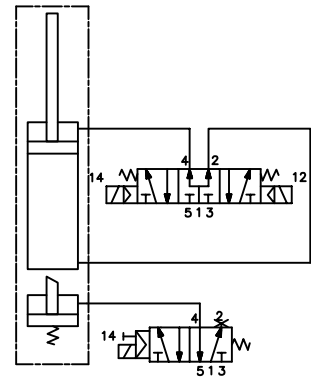

Size	Holding moment	Max. torque at the rotary table 0,55 MPa	Weight
600	8000 Nm	600 Nm	59.7 Kg

Min./Max. operating pressure: **0,4 / 0,6 MPa**

Operating temperature: **5° ± 45° C**

Predetermine pivot rotation in degrees: **45° - 60° - 90° - 120°**

Electronic sensor with M12 swivel connector that can be orientated at 0° or 90°

Supply voltage: 10÷30 Vdc

IP code: **IP 65**

\* : TOLERANCE BETWEEN DOWEL HOLES ± 0.02, TO SCREW HOLES ± 0.1



## Pneumatic power pivot

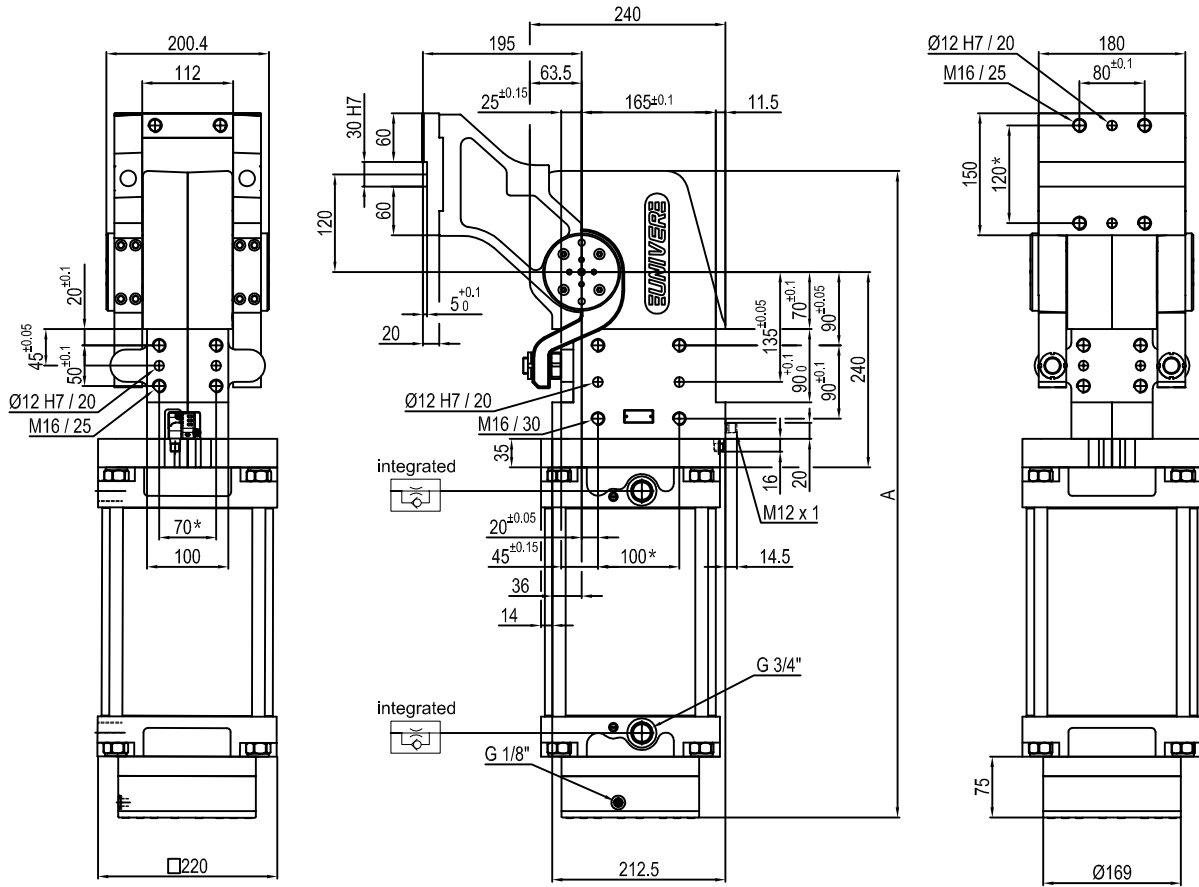

Pivot rotation in degrees	A
45°	702
60°	718
90°	755
120°	794

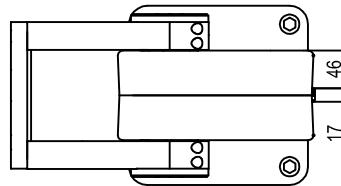

## Passive brake

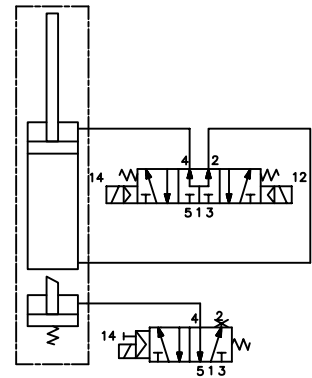

Size	Holding moment	Max. torque at the rotary table 0,55 MPa	Weight
600	8000 Nm	600 Nm	59.7 Kg

Min./Max. operating pressure: 0,4 / 0,6 MPa

Operating temperature: 5° + 45° C

Predetermine pivot rotation in degrees: 45° - 60° - 90° - 120°

Electronic sensor with M12 swivel connector that can be orientated at 0° or 90°

Supply voltage: 10÷30 Vdc

IP code: IP 65

\* : TOLERANCE BETWEEN DOWEL HOLES ± 0.02, TO SCREW HOLES ± 0.1

Subject to technical modifications without notice.

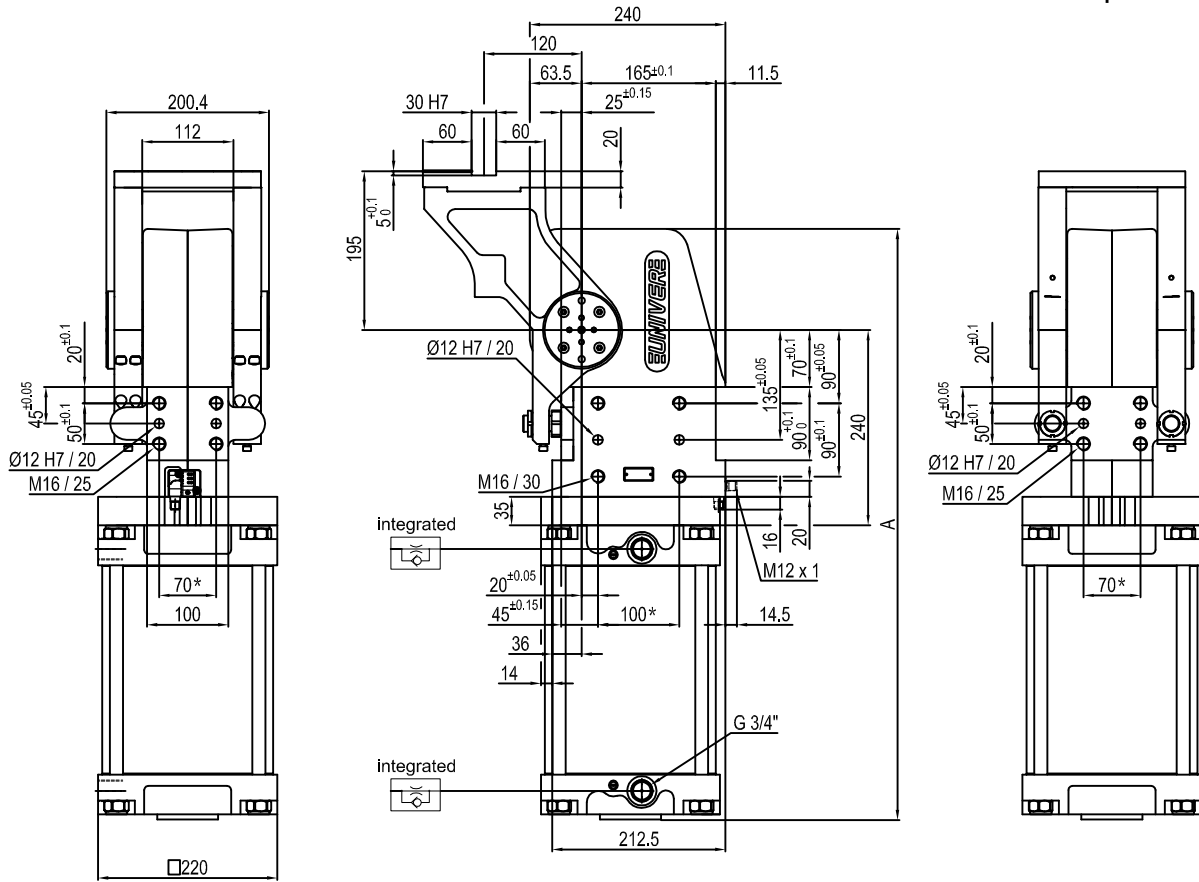

Pivot rotation in degrees	A
45°	633
60°	649
90°	686
120°	725

Size	Holding moment	Max. torque at the rotary table 0,55 MPa	Weight
600	8000 Nm	600 Nm	53.8 Kg

Min./Max. operating pressure: **0,4 / 0,6 MPa**

Operating temperature: **5° ± 45° C**

Predetermine pivot rotation in degrees: **45° - 60° - 90° - 120°**

Electronic sensor with M12 swivel connector that can be orientated at 0° or 90°

Supply voltage: 10÷30 Vdc

IP code: **IP 65**

\* : TOLERANCE BETWEEN DOWEL HOLES ± 0.02, TO SCREW HOLES ± 0.1

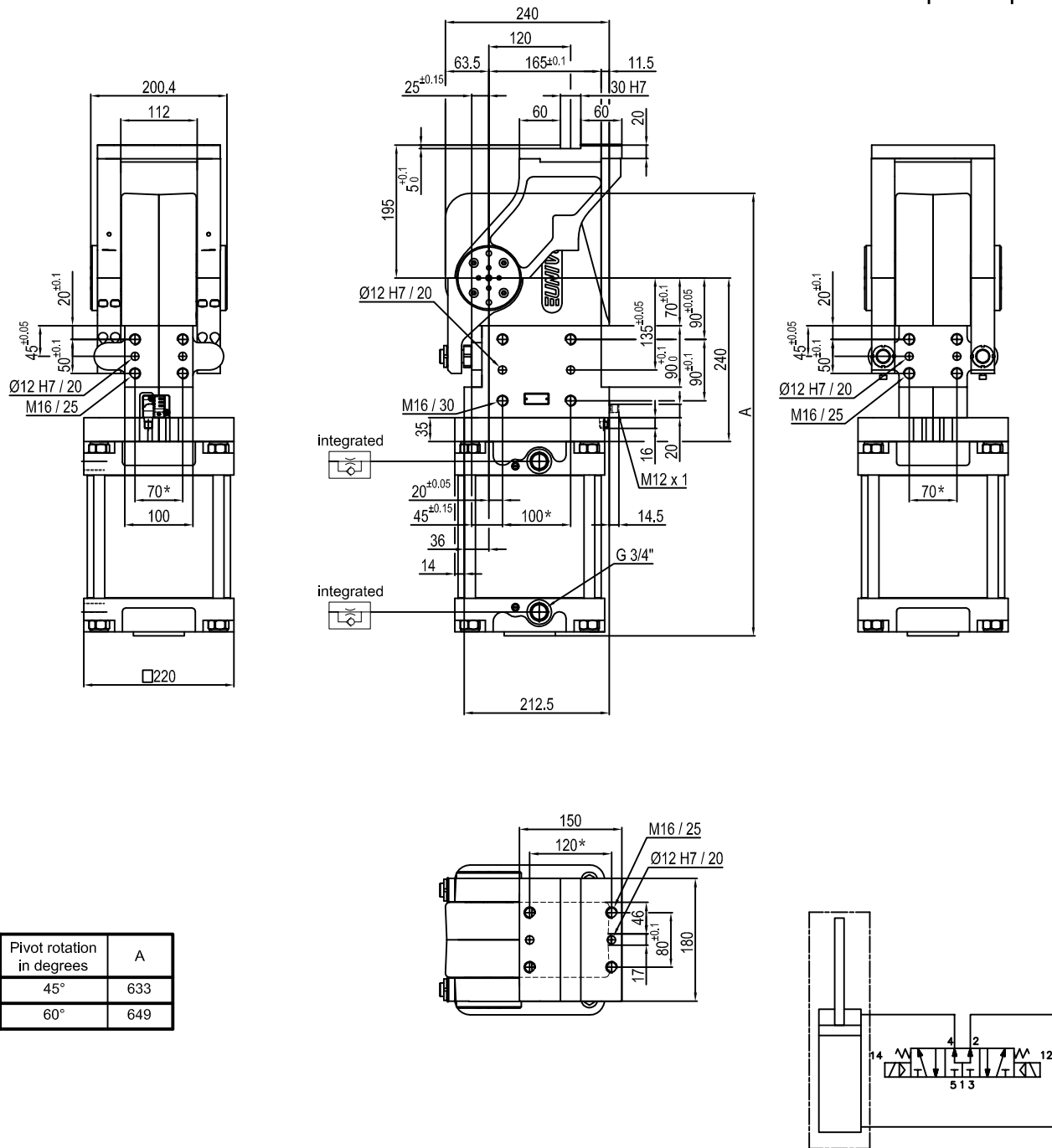

Pivot rotation in degrees	A
45°	633
60°	649

Size	Holding moment	Max. torque at the rotary table 0,55 MPa	Weight
600	8000 Nm	600 Nm	53.8 Kg

Min./Max. operating pressure: **0,4 / 0,6 MPa**

Operating temperature: **5° ± 45° C**

Predetermine pivot rotation in degrees: **45° - 60°**

Electronic sensor with M12 swivel connector that can be orientated at 0° or 90°

Supply voltage: 10÷30 Vdc

IP code: **IP 65**

\* : TOLERANCE BETWEEN DOWEL HOLES ± 0.02, TO SCREW HOLES ± 0.1

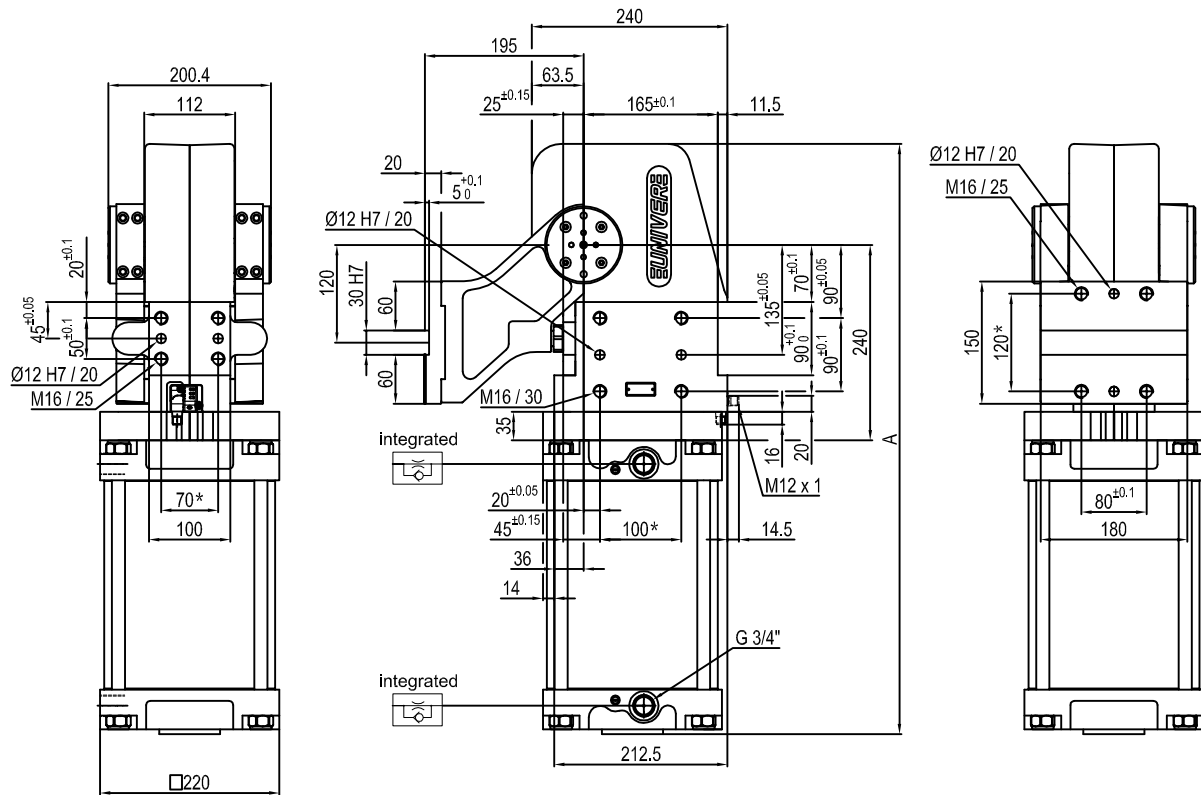

Pivot rotation in degrees	A
45°	633
60°	649
90°	686
120°	725

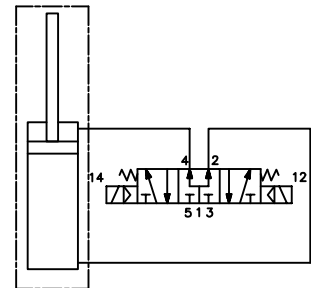
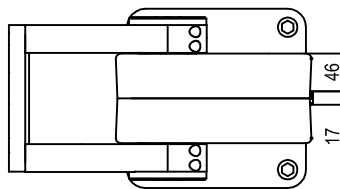

Size	Holding moment	Max. torque at the rotary table 0,55 MPa	Weight
600	8000 Nm	600 Nm	53.8 Kg

Min./Max. operating pressure: **0,4 / 0,6 MPa**

Operating temperature: **5° ± 45° C**

Predetermine pivot rotation in degrees: **45° - 60° - 90° - 120°**

Electronic sensor with M12 swivel connector that can be orientated at 0° or 90°

Supply voltage: 10÷30 Vdc

IP code: **IP 65**

\* : TOLERANCE BETWEEN DOWEL HOLES ± 0.02, TO SCREW HOLES ± 0.1

Subject to technical modifications without notice.

## Pneumatic power pivot

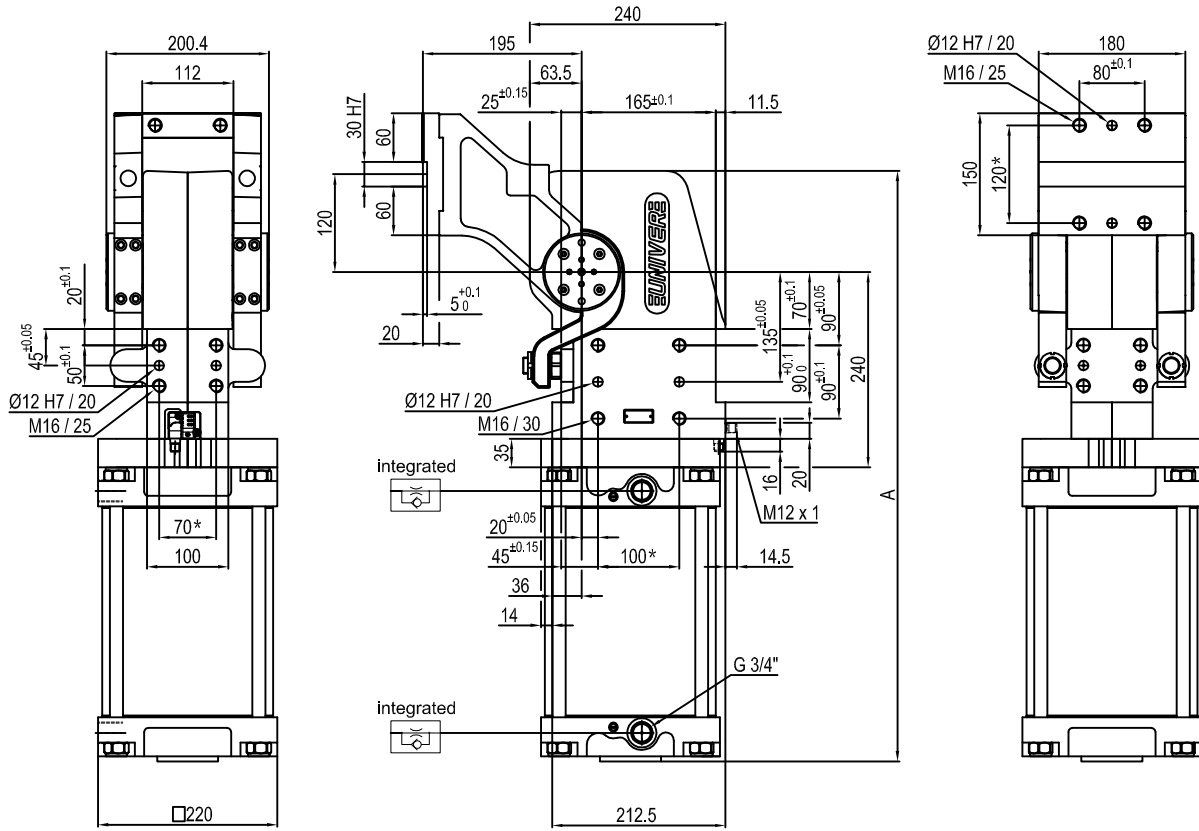

Pivot rotation in degrees	A
45°	633
60°	649
90°	686
120°	725

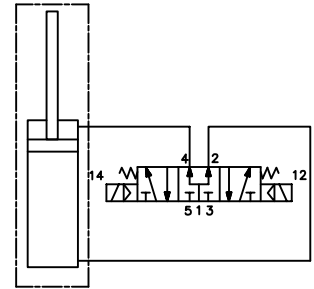
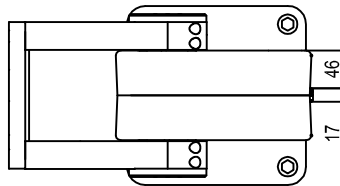

Size	Holding moment	Max. torque at the rotary table 0,55 MPa	Weight
600	8000 Nm	600 Nm	54 Kg

Min./Max. operating pressure: **0,4 / 0,6 MPa**

Operating temperature: **5° ± 45° C**

Predetermine pivot rotation in degrees: **45° - 60° - 90° - 120°**

Vertical arm mount position

Electronic sensor with M12 swivel connector that can be orientated at 0° or 90°

Supply voltage: 10÷30 Vdc

IP code: **IP 65**

\* : TOLERANCE BETWEEN DOWEL HOLES ± 0.02, TO SCREW HOLES ± 0.1