

30

YEARS

AUTOMOTIVE
 DIVISION



Car Manufacturers which use our Clamps





A **single supplier**
with **a complete**

Pneumatic Components
for **Automation**

Clamping
for **Autom**



product range for

Technology
otive

GR8
Modular Tooling System

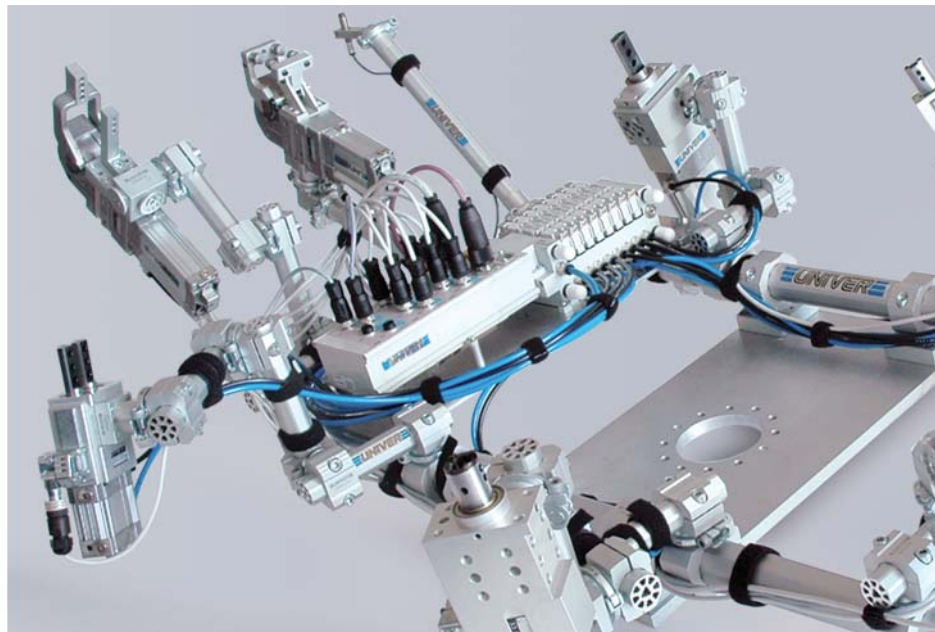



Our customers

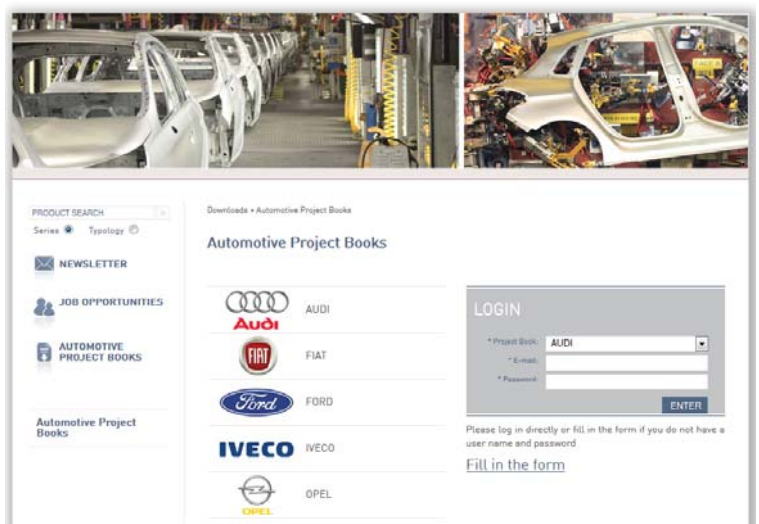

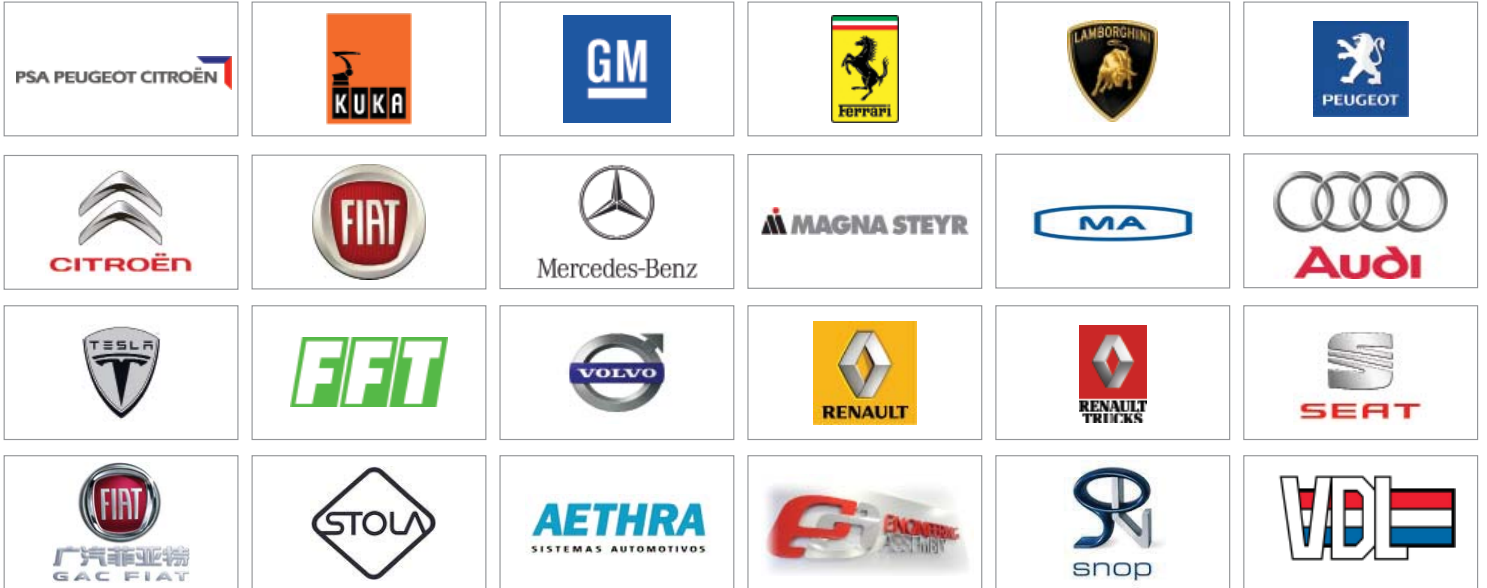

Online Project Books
www.univer-group.com





Complete range

Clamping Technology



Pneumatic Power

■ UBP

UNIVERSAL Pneumatic power clamp



■ UBH

UNIVERSAL Pneumatic power clamp



■ UBM

UNIVERSAL Pneumatic power clamp with handlever



■ IBM

Pneumatic power clamp with handlever interchangeable with size 50/63 mm



Gripper Units



■ UGP

Pneumatic gripper units



■ UGM

Pneumatic gripper unit with handle



■ LGP

Pneumatic gripper



NEW

PATENTS PENDING

Clamps

■ IBP

Pneumatic power clamp interchangeable with size 50/63 mm



■ UBS

Safety pneumatic power clamp



■ UDP

Pneumatic power clamp with 2 arms



■ UBQ

Pneumatic power clamp with handle



■ UBT

Pneumatic power clamp with central handle



■ UFL - UHL

Manual power clamps





Complete range

Pin Packages

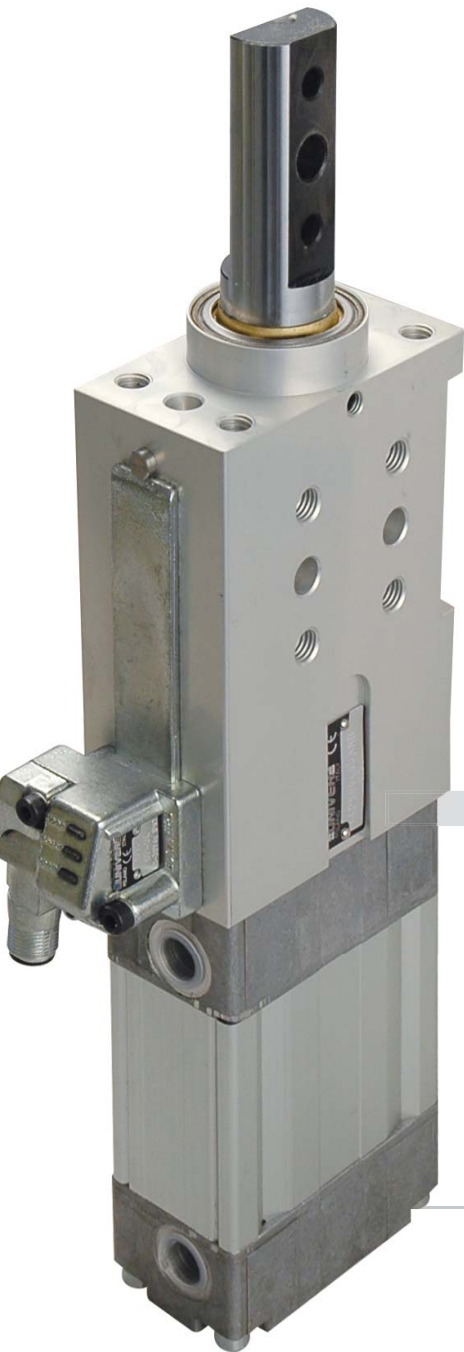

■ LCX

Pneumatic retractable locating pin unit with two rods and handle lever and toggle-joint mechanism



Retractable locating single and double rod

■ LCP

Pneumatic retractable locating pin units with single rod



■ LCG

Pneumatic retractable locating pin units with single rod



Pneumatic retractable locating pin units with handlever



■ LCM

Pneumatic retractable locating pin unit with handlever



■ LCL

Manual retractable locating pin unit



■ LCO

Pneumatic retractable locating pin unit with two rods and handlever



■ LCY

Pneumatic retractable locating pin unit with handlever and toggle-joint mechanism



pin units

■ LCZ

Pneumatic retractable locating pin units with single rod and toggle-joint mechanism



■ LCJ

Pneumatic retractable locating pin units, with improved pull force



■ LCA

Pneumatic retractable locating pin units with double rod



■ LCT

Pneumatic retractable locating pin units with double rod and toggle-joint mechanism





Complete range

Pin Clamps

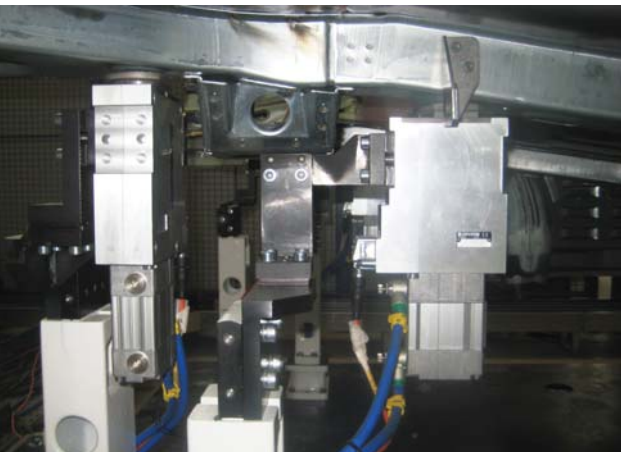

Pneumatic pin clamps

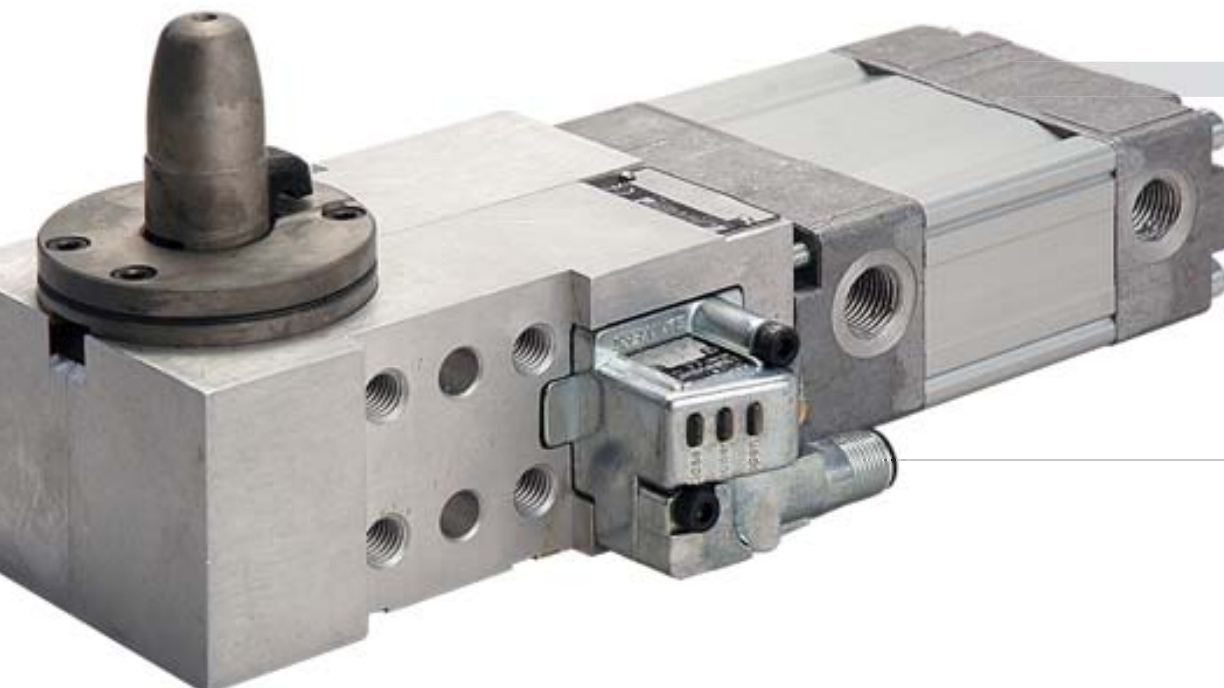

■ LSP

Pneumatic pin clamp



Clamps conforming to the **NAAMS/CNOMO** standard

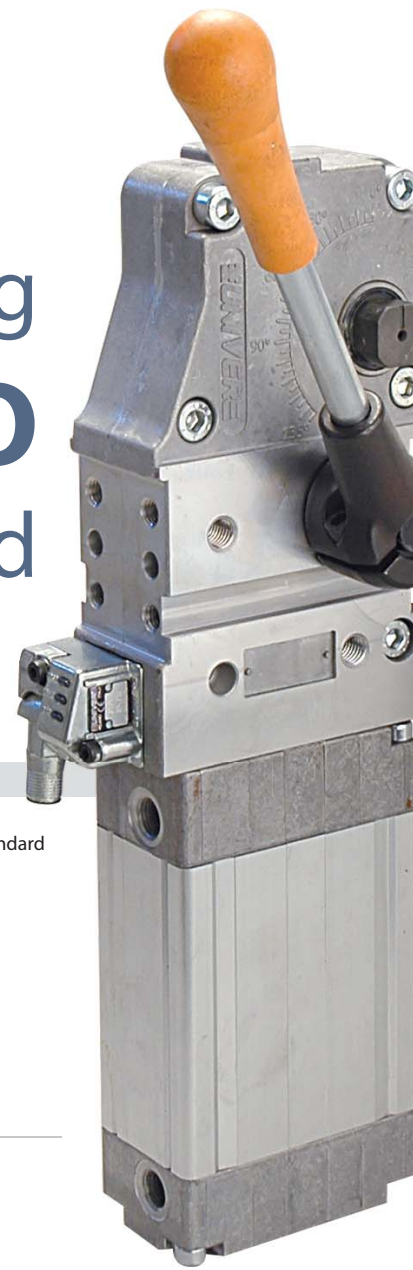

■ UNP

Pneumatic power clamps conforming to the N.A.A.M.S. Standard



■ UNM

Pneumatic power clamps with handlever conforming to the N.A.A.M.S. Standard



■ DMS

Pneumatic power clamps conforming to the CNOMO Standard



■ LSP50U

Pneumatic pin clamp - horizontal shape



■ LTP

Pneumatic pin clamp with vanishing hook



■ LUP

Pneumatic pin clamp with vanishing hook and pin



■ LSL

Manual pin clamp





Complete range

Pivot Units

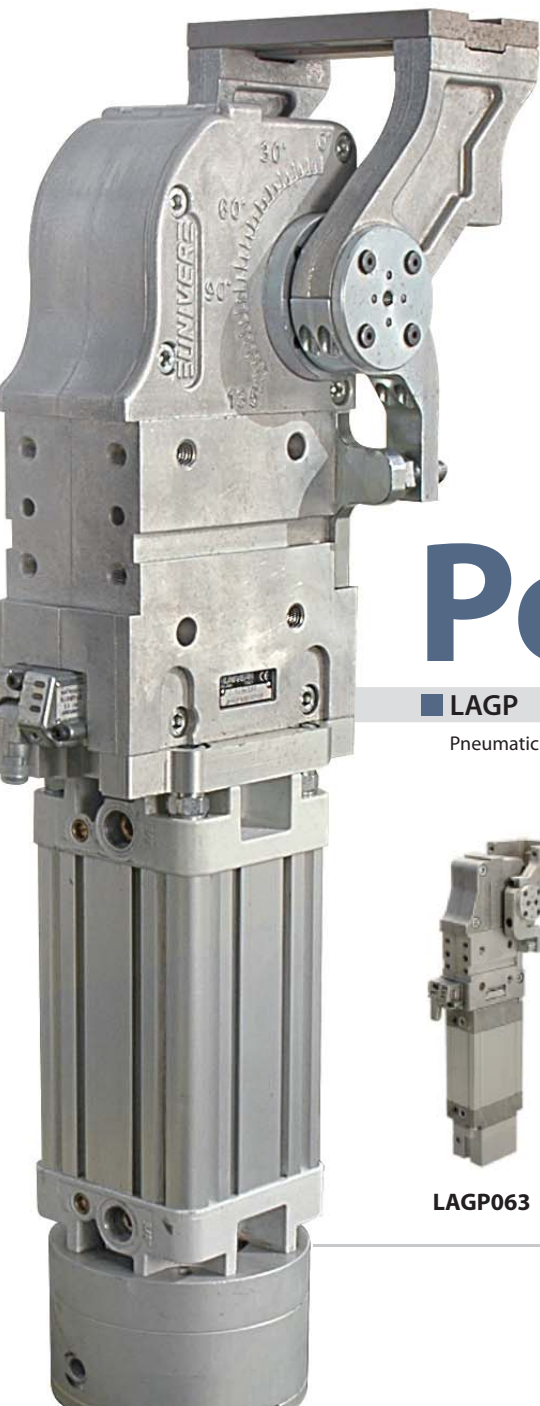

Power Pivots

■ LAGP

Pneumatic power pivots



LAGP063

LAGP075

LAGP080

LAGP120

LAGP155

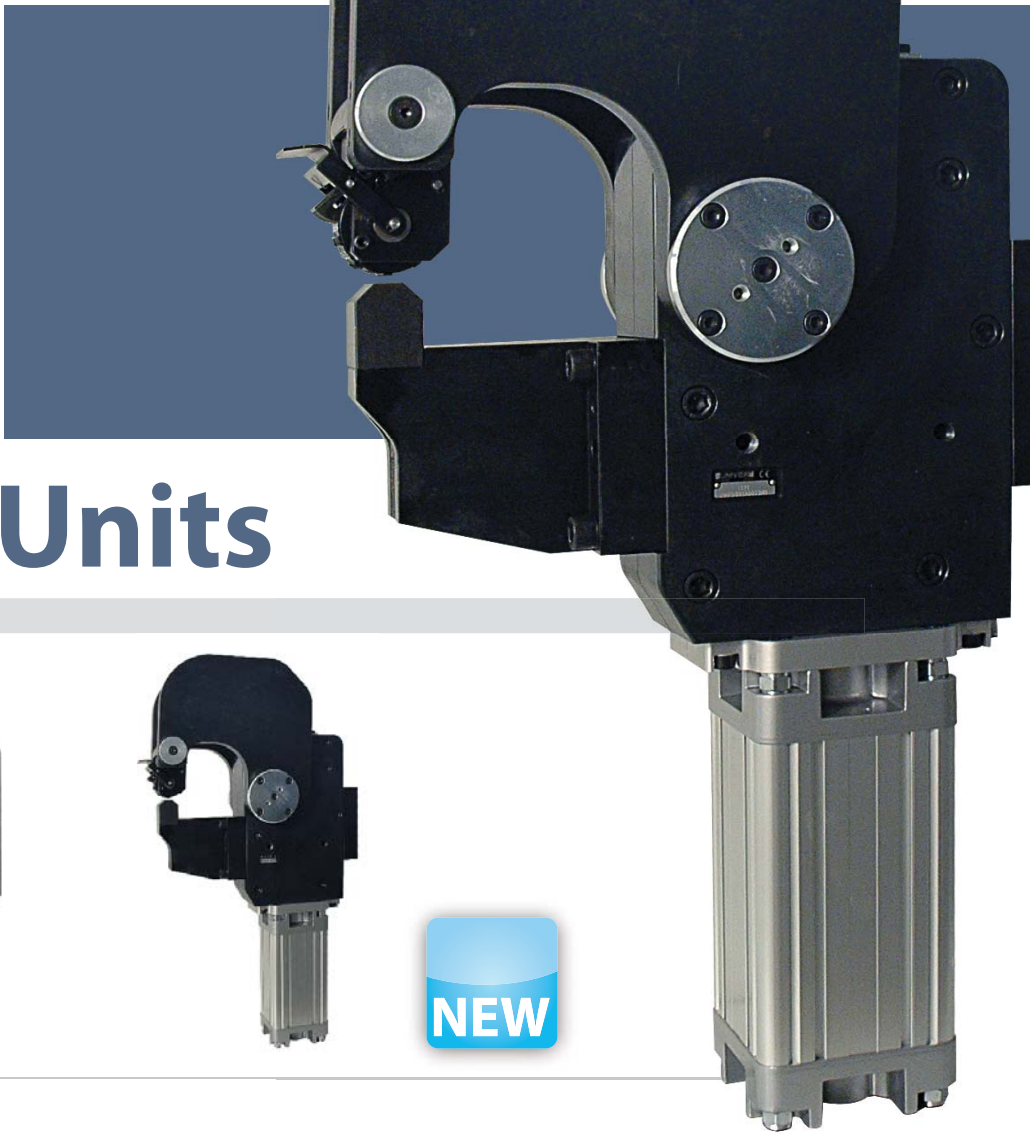

Marking Units

■ PRP

Pneumatic marking unit



NEW



LAGP170



LAGP210



LAGP300-350



LAGP600-605



DMA200



Complete range

Electric Units

LAGE

Electric power pivots



Electric units

LAE

Electric power clamps

LNE

Electric power clamps, fixing conforming to the N.A.A.M.S. Standard

LGE

Electric gripper units



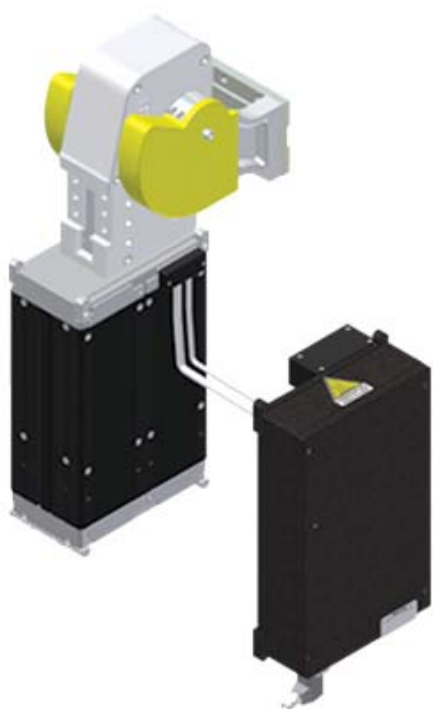

■ LCE

Electric retractable locating pin unit

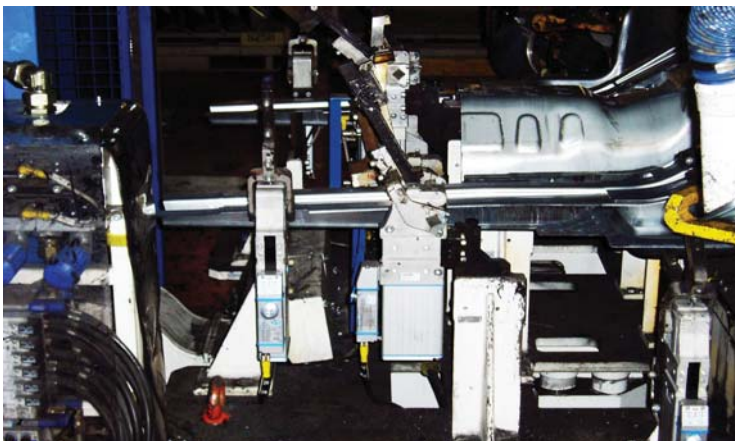



Complete range

Pneumatic Automation for Automotive

■ K

ISO 15552
Pneumatic Cylinders



■ KD

Ø 32 ÷ 125 mm
ISO 15552
Pneumatic Cylinders
HEAVY SERIES TUBE



■ RM

Ø 16 ÷ 100 mm - ISO 21287
Compact Cylinders



■ JL

Guided Compact
Cylinders



Valves

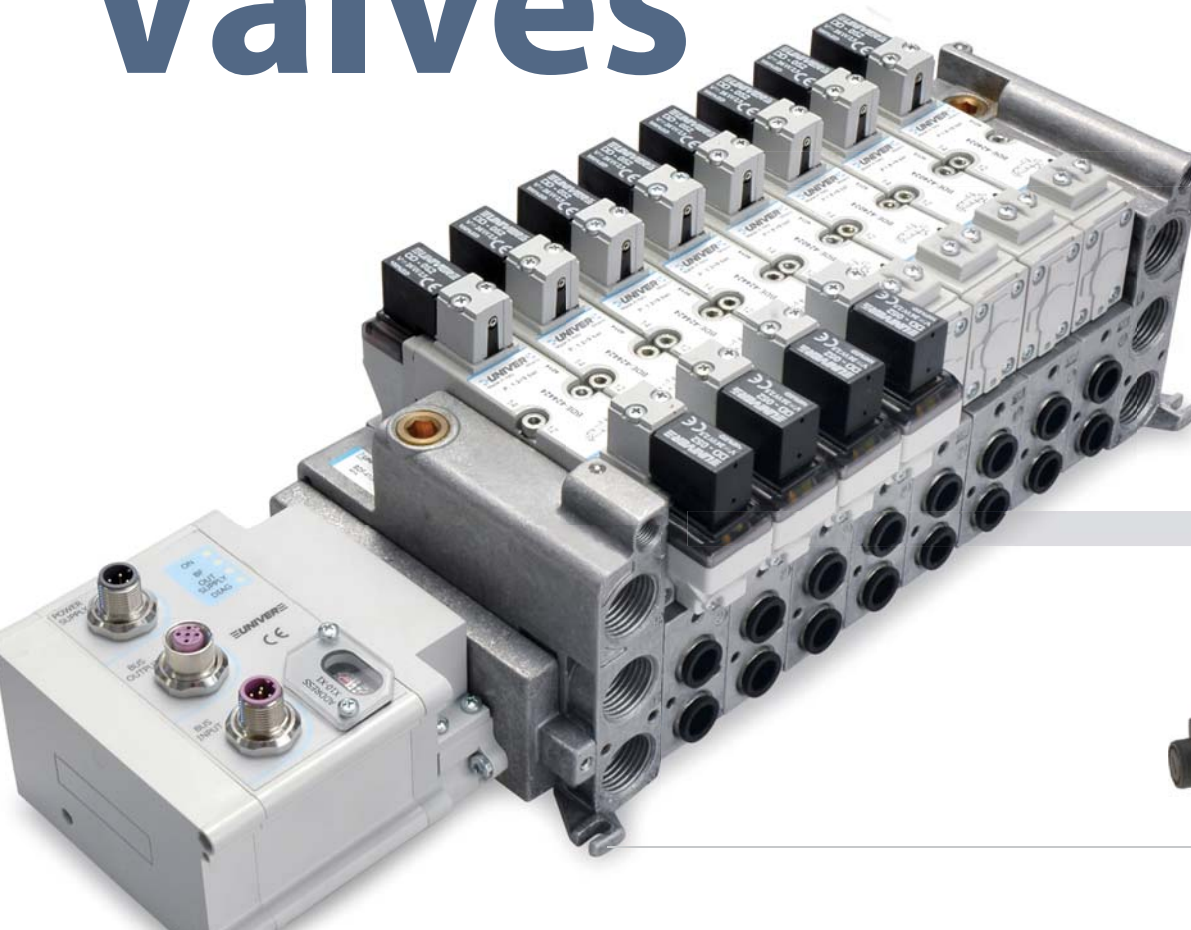

■ BE

ISO 5599/1 Valves size 1-2-3-4



■ AC

Mixed Valves G1/8-G1/4-G1/2



Cylinders

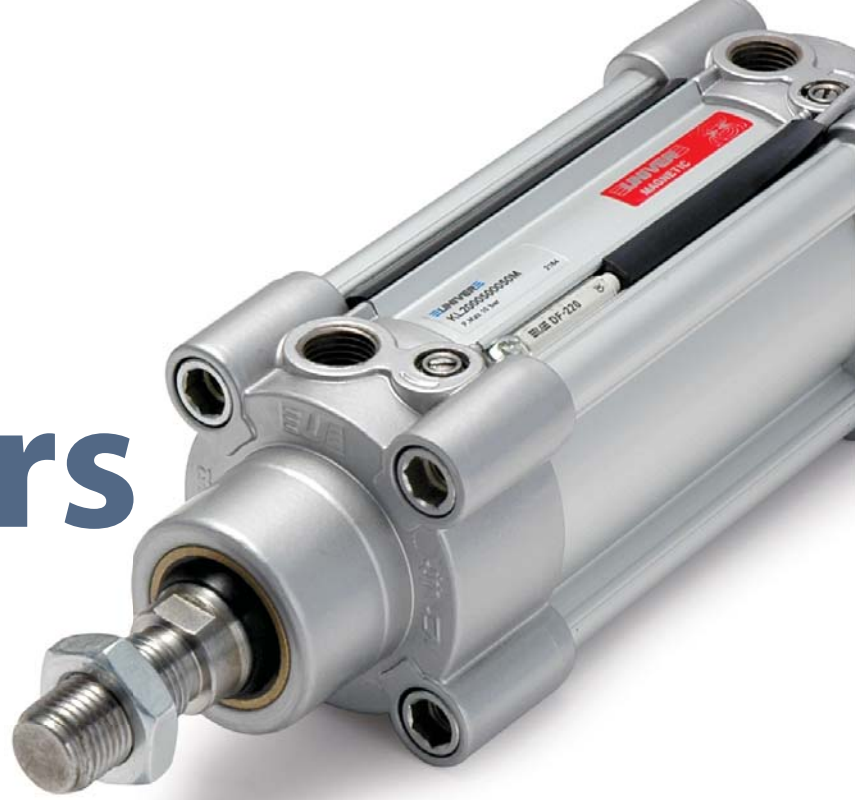

R

Ø 32 ÷ 125 mm
Pneumatic Rotary Actuators



S1

Ø 16 ÷ 50 mm
Rodless Cylinders
Standard version



J

Slide Units
for pneumatic cylinders



RT

Ø 25 ÷ 63 mm
2/3 stage
Telescopic Pneumatic Cylinders



L1-N

Locking unit for
cylinders and piston rods



BE12

ISO 5599/1 Valves size 1-2-3-4



BD 18mm

ISO 15407 -1/2 Valves



BD 26mm

ISO 15407 -1/2 Valves



AG

Poppet Valves for vacuum
G1/8 ÷ G1 1/2



P15

15 mm COMPACT Valves



TC

Serial Communication Systems



CANopen

PROFINET

PROFIBUS

DeviceNet

EtherCAT

EtherNet/IP



Complete range

Pneumatic Automation for Automotive

Air Treatment

- HZE-Y Gradual starter
- HZE-N Diverter block
- HZE-P Lockable valve
- HZE-S Shutt-off valve
- HZE-RL Lockable regulator



- HB Nickel-plated Brass Push-in Fittings
- HA Technopolymer Push-in Fittings



HZE

Size 0 - 1 - 2

G1/4 ÷ G3/4

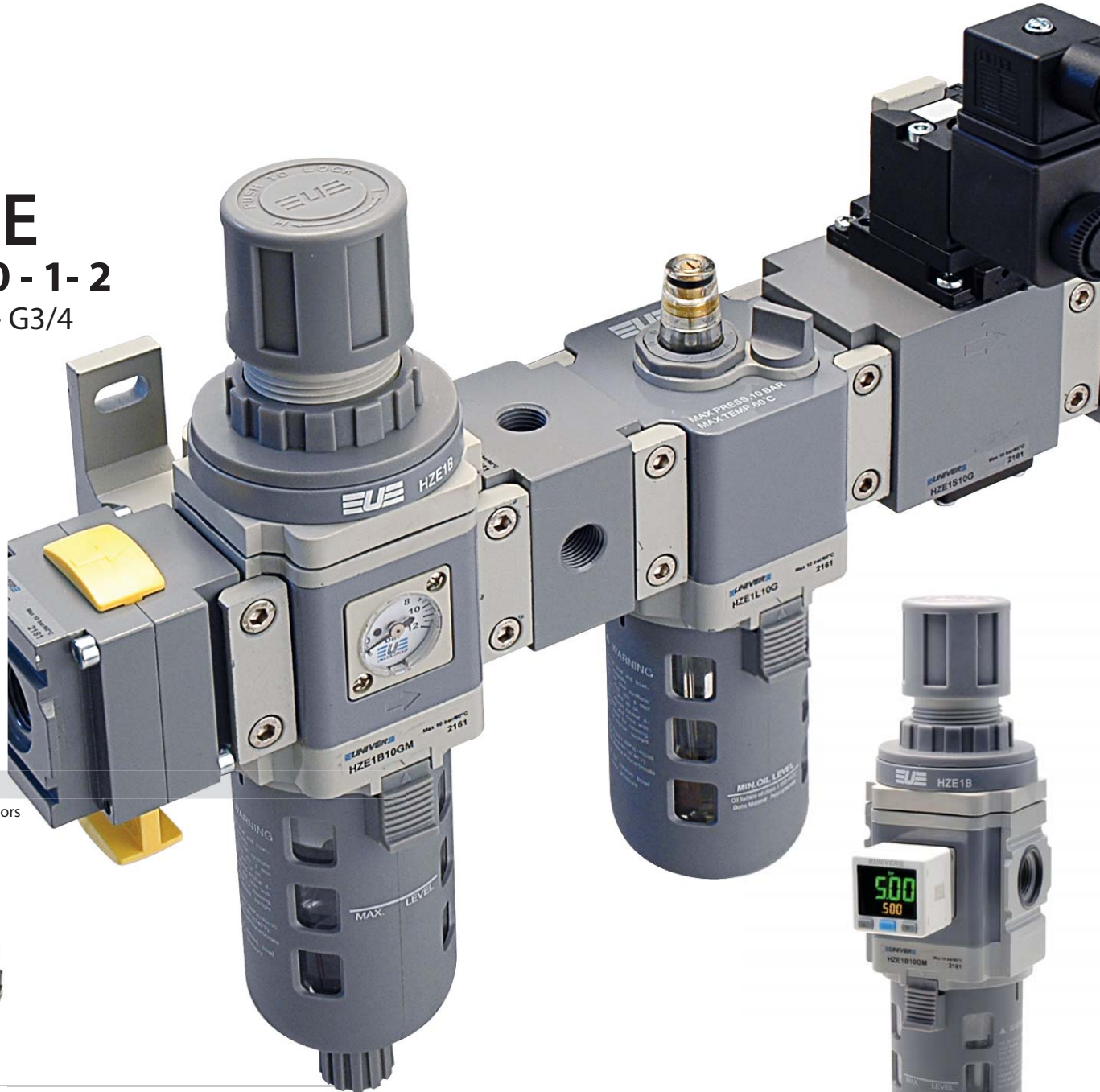

■ HZIP20
Precision regulators

Accessories

■ HGU

Quick Couplings for Compressed Air



■ HC

Fittings and Accessories with pneumatic functions



■ AM-55

Blocking valve



■ AM-53

Economizer G1/8 ÷ G1





GR8

Modular Tooling System

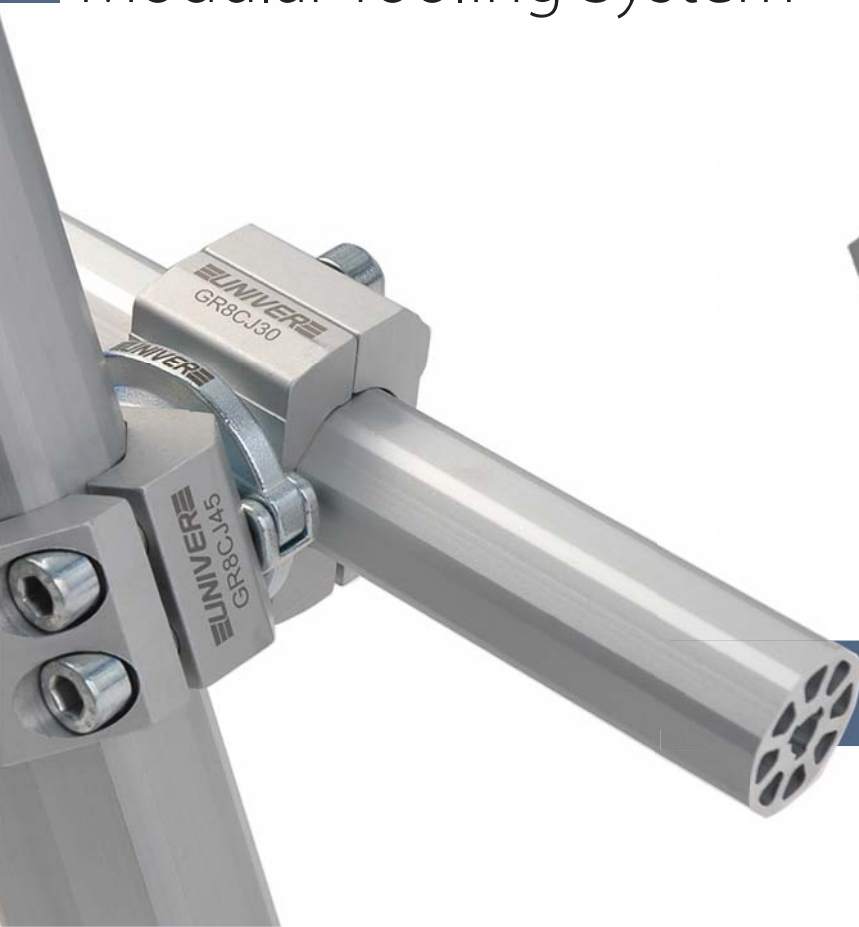

KIT

Considerable **reduction**

Ø 30 - 45 - 70 mm booms

Maximum stiffness and minimum weight



**PATENT
PENDING**

30



45



70



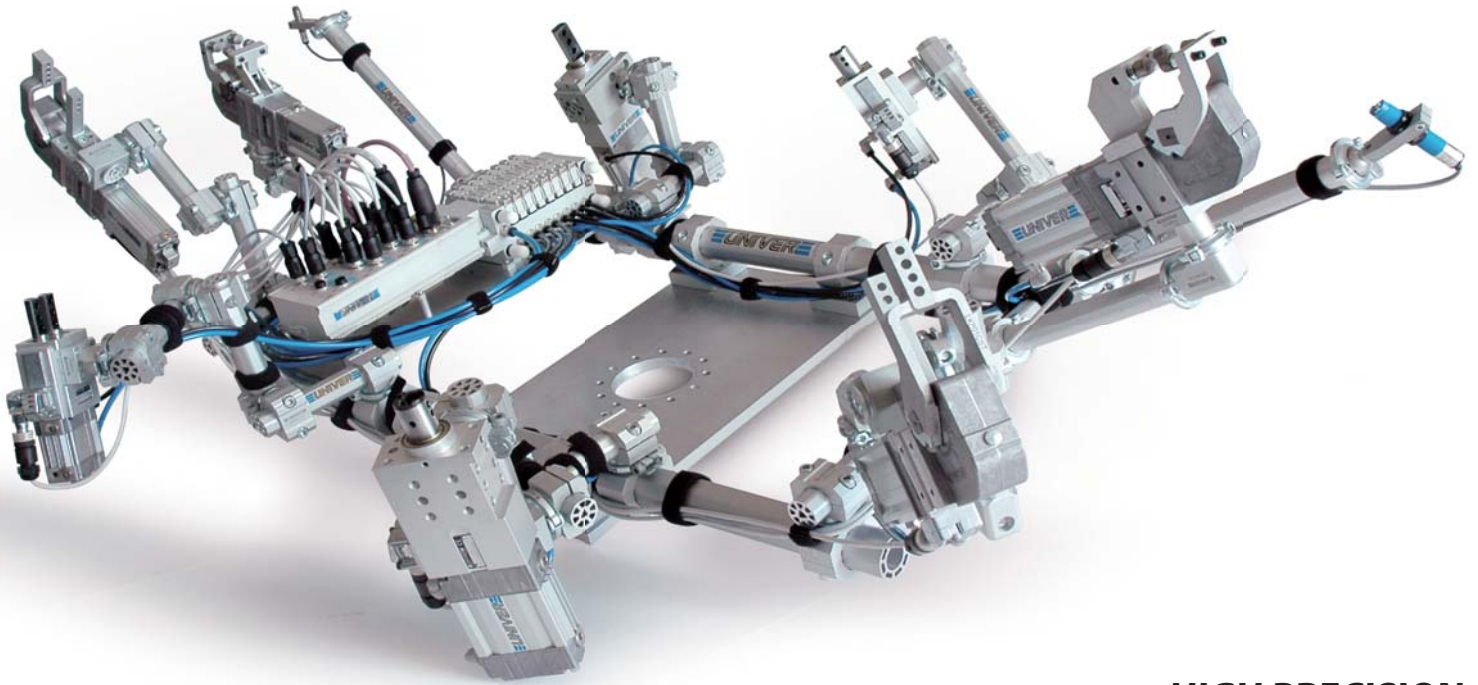

of mounting elements

HIGH PRECISION

High level of positional repeatability; low deflection

MODULAR COMPONENTS

Considerable reduction of mounting components

QUICK INSTALLATION AND SET UP

No welding or doweling required,
easily replaceable components

FULLY ADJUSTABLE

Unlimited orientation in space and free configuration

Locking ring

Precise and efficient system to guarantee a high level of positional accuracy

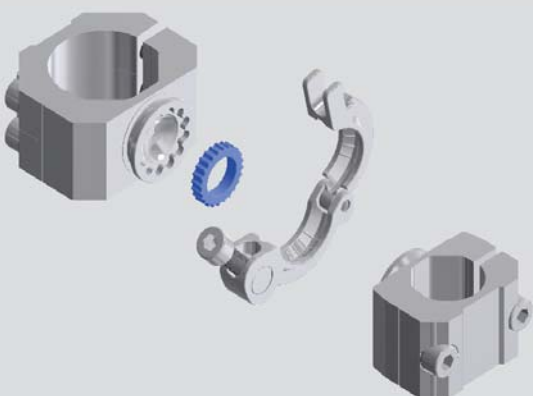

Ball mounting

Unlimited swivel rotation

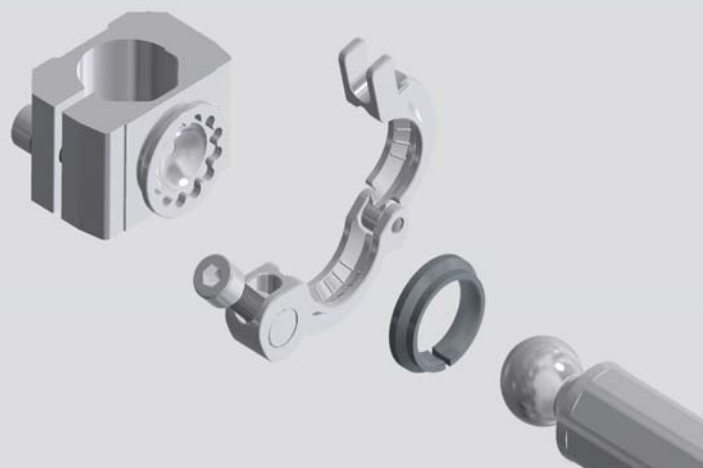



GR8

End Effectors

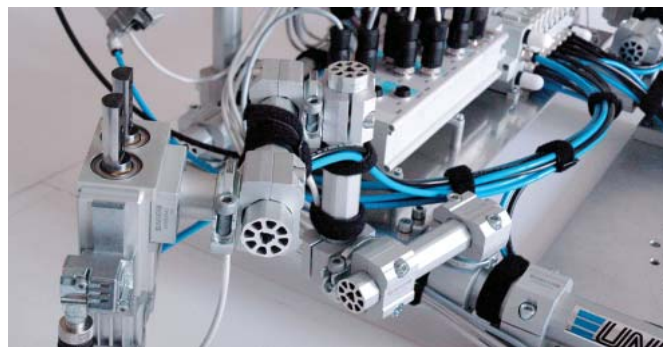
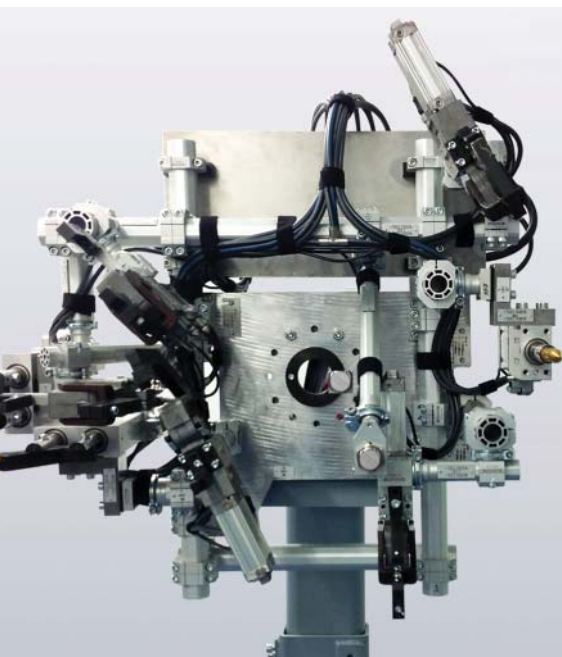

Unlimited and complex configurations
Weight-optimized standard components and brackets
Quick installation and adjustment

Applications and details

Complete Solution with UNIVER Components

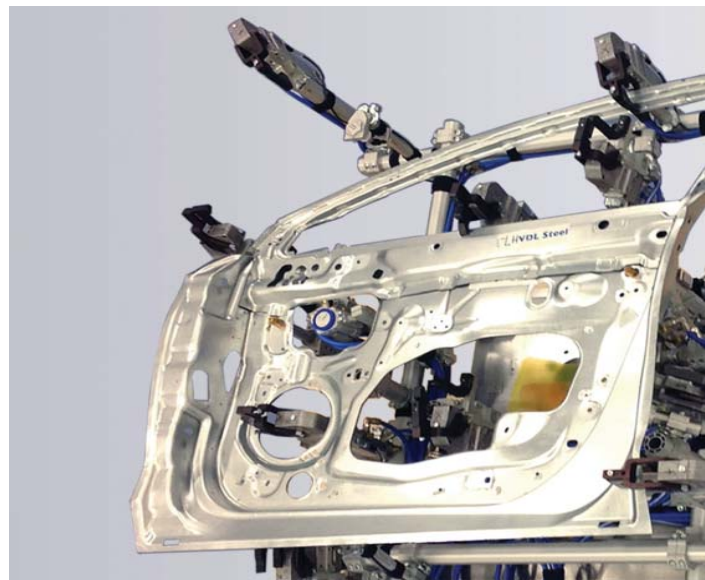
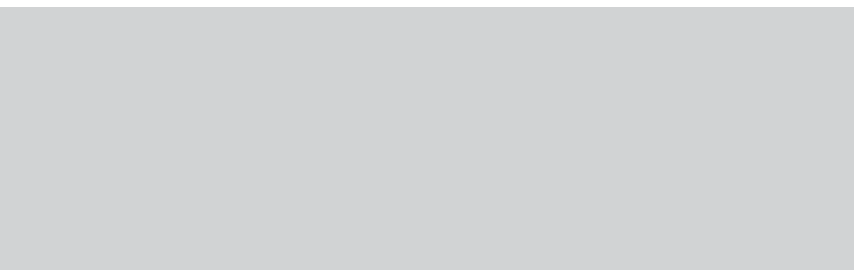
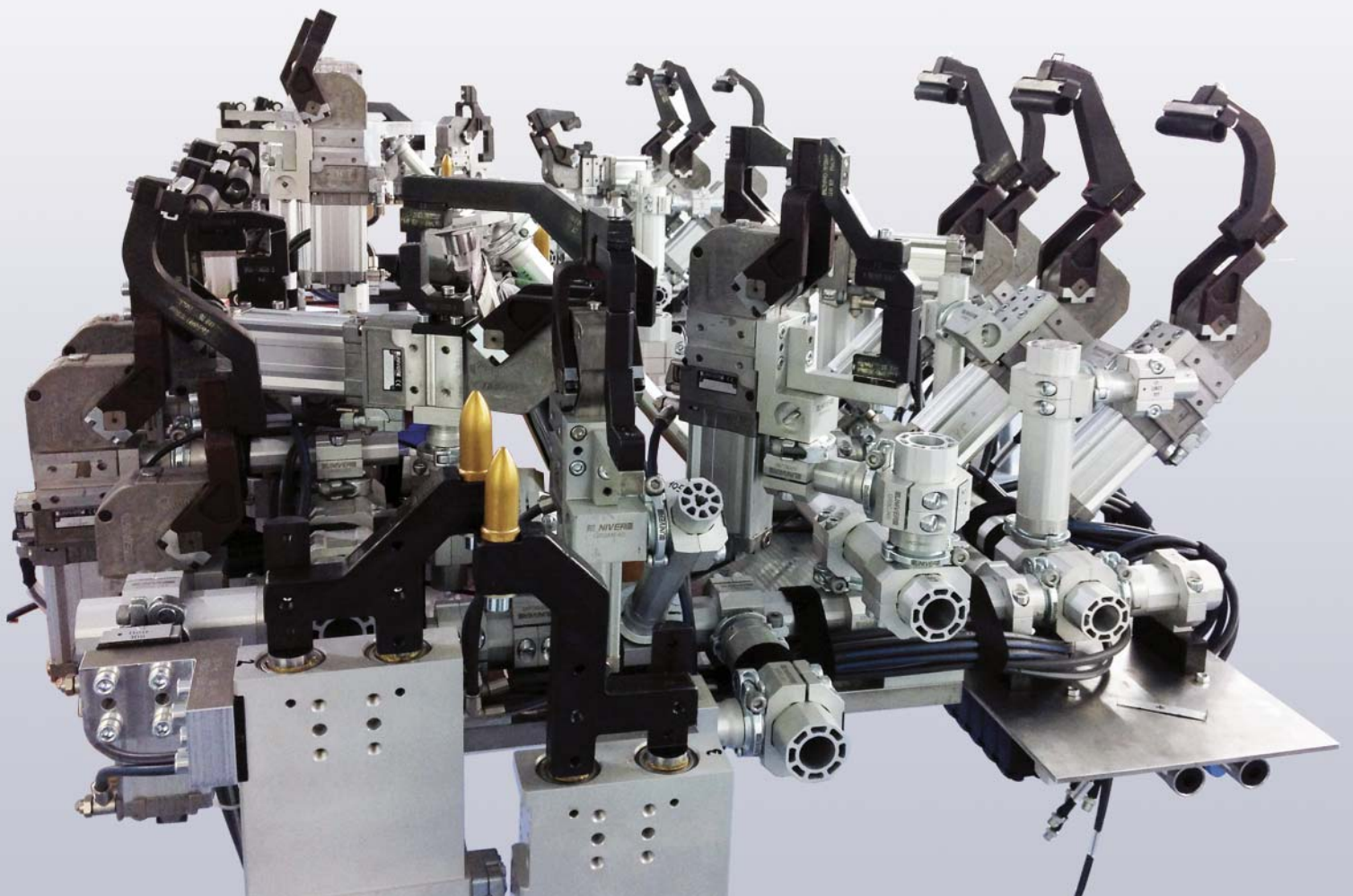



Pneumatic Automation | Automotive

Download our PRODUCT OVERVIEW

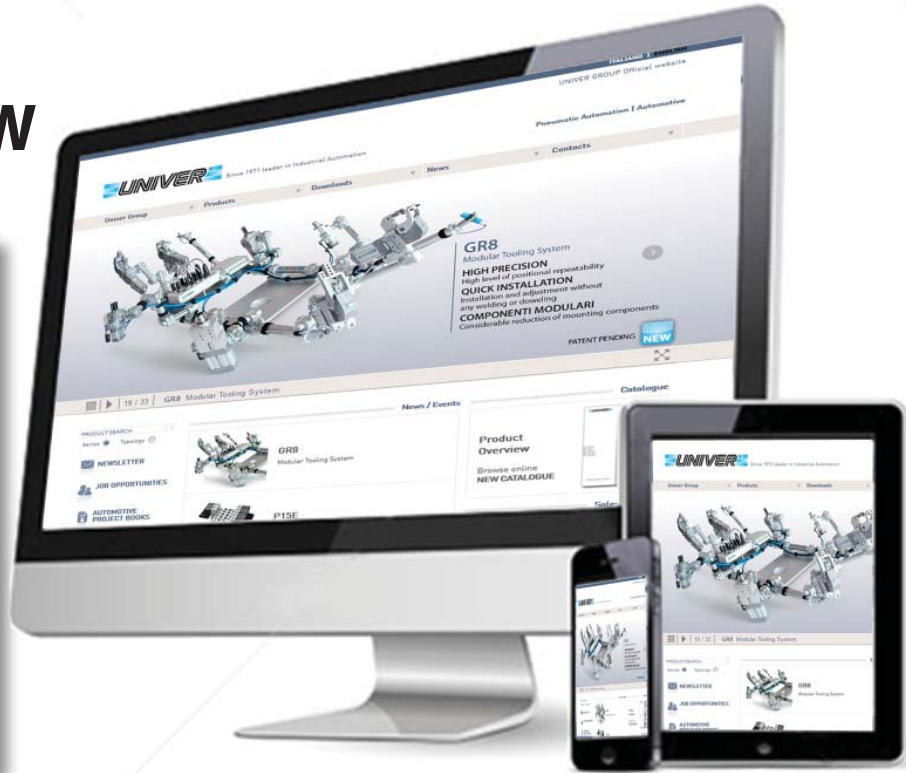

www.univer-group.com

UNIVER S.p.A. Headquarters

I - 20128 Milano
Via Eraclito, 31
Tel. +39 02 25298.1
Fax +39 02 2575254
info@univer-group.com
www.univer-group.com

UNIVER DO BRASIL S/A

Av. Rui Barbosa, 3005 - Ipê
São José dos Pinhais - PR
83055-320, Brasil
Tel. +55 41 3155-4200
Fax +55 41 3155-4205
atendimento@univer.com.br
www.univer.com.br

