

UBQ40

UNIVERSAL Power clamps



U	B	Q	4	0	N	N	K	
1	2	3	4	5	6	7		

1 Series	2 Version	3 Size
----------	-----------	--------

UB = UNIVERSAL Power clamps
fully adjustable opening angle:
0° to 135° Max
The opening angle range may vary
according to the arm position and style

Q = Pneumatic with manual lever

40 = Ø 40 mm

4 Arm position	5 Arm style	6 Sensor
----------------	-------------	----------

V = 90° **O** = 180° **N** = No arm

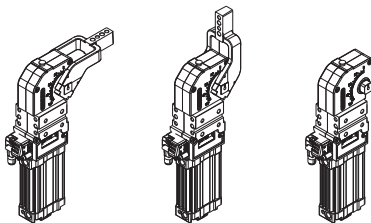

C = Central, 15 mm offset
D = Right, 15 mm offset
S = Left, 15 mm offset
E = Central, 45mm offset
F = Right, 45mm offset
L = Left, 45mm offset
X* = Central, oversized dowel holes Ø 8 H7, 15 mm offset
Y* = Right, oversized dowel holes Ø 8 H7, 15 mm offset
Z* = Left, oversized dowel holes Ø 8 H7, 15 mm offset
N = No arm
***** = Available upon request

N = No sensor
(with protection plate)
K = Electronic sensor PNP (optical)
(DF-K)
D = Pneumatic sensor

7 Arm material

S = Steel
If not specified the aluminium version
is supplied

UBQ40NNK

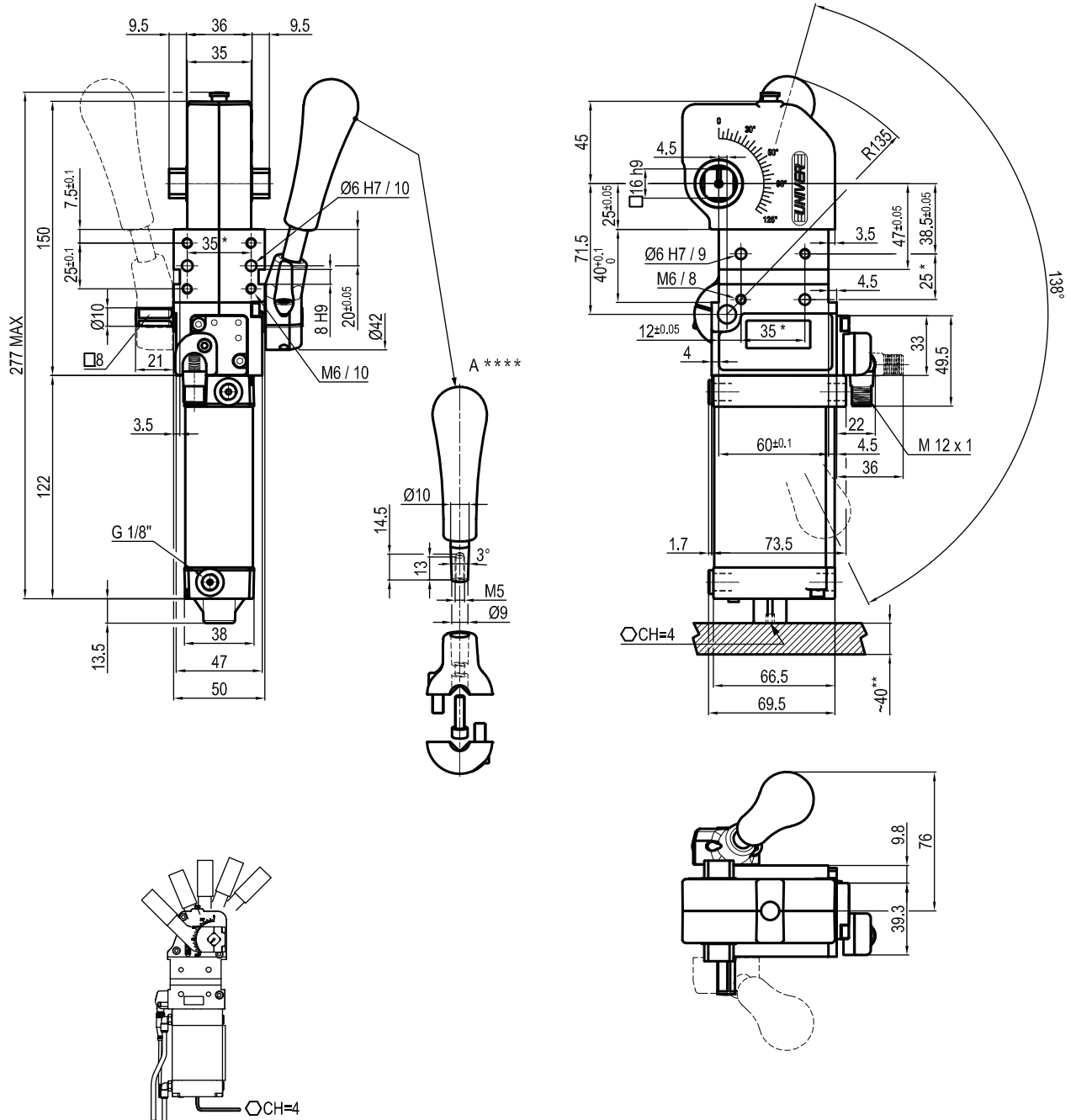

Bore Ø	Holding moment	Clamping moment (0,5 MPa)	Weight (clamping arm not included)
40 mm	600 Nm	170 Nm	1,8 Kg

Min./Max. operating pressure: **0,4 / 0,6 MPa**
 Operating temperature: **5° ÷ 45° C**
 Opening angle: **adjustable**
 Without arm
 With manual lever
 Electronic sensor with M12 swivel connector, from 0° to 90°
 Supply voltage: 10 ÷ 30 Vdc
 IP code: **IP 65**
 Pneumatic ports on both sides

* : TOLERANCE BETWEEN DOWELS ± 0,02, BETWEEN SCREW HOLES ± 0,1
 ** : AREA TO ACCESS ANGLE ADJUSTMENT
 ***: DIMENSIONS TO BE RESPECTED IN CASE OF OTHER MANUAL LEVERS ARE USED
 ****: DIMENSIONS TO BE RESPECTED IN CASE OF OTHER MANUAL LEVERS ARE USED

Subject to technical modifications without notice

LKP01CST

□ 16 mm - offset 15 mm

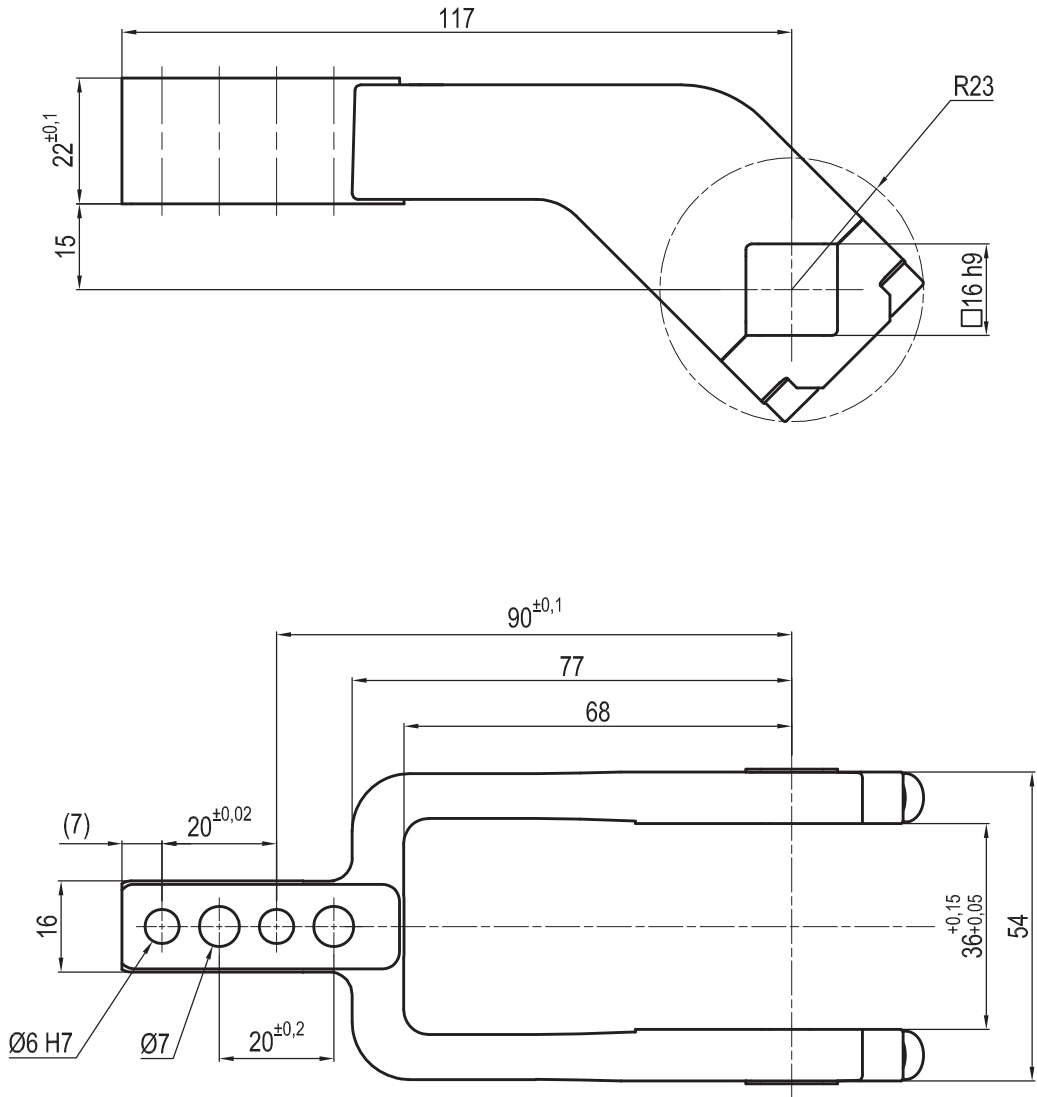

Clamp size	Material	Weight
40 mm	Aluminium	0,2 Kg

THE CLAMPING ARM INCLUDES THE NECESSARY SCREWS

Subject to technical modifications without notice

UP120151442S

□ 16 mm - offset 15 mm

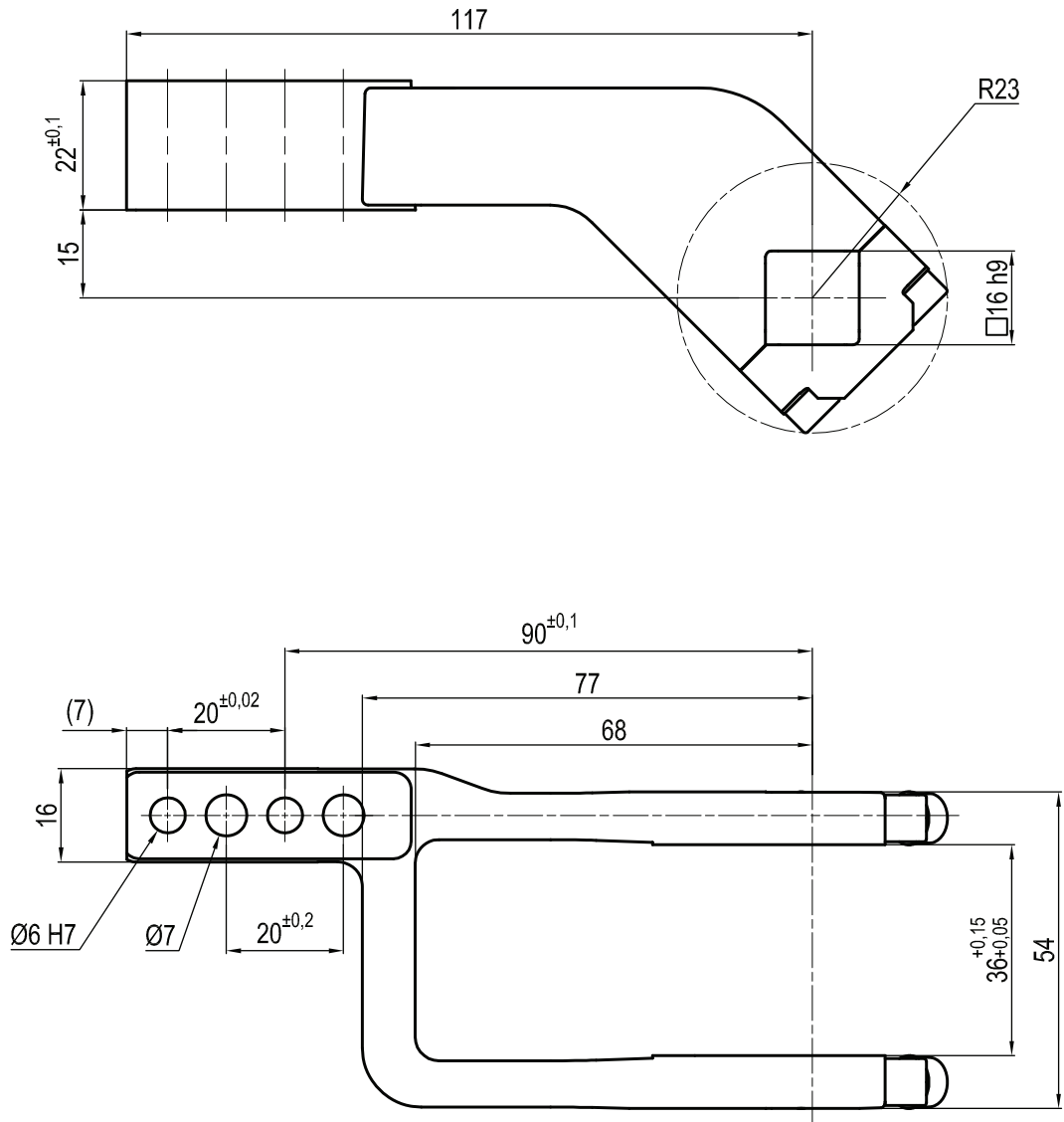

Clamp size	Material	Weight
40 mm	Steel	0,4 Kg

THE CLAMPING ARM INCLUDES THE NECESSARY SCREWS

Subject to technical modifications without notice

Rev. 01 15.01.16

UP120151443S

□ 16 mm - offset 15 mm

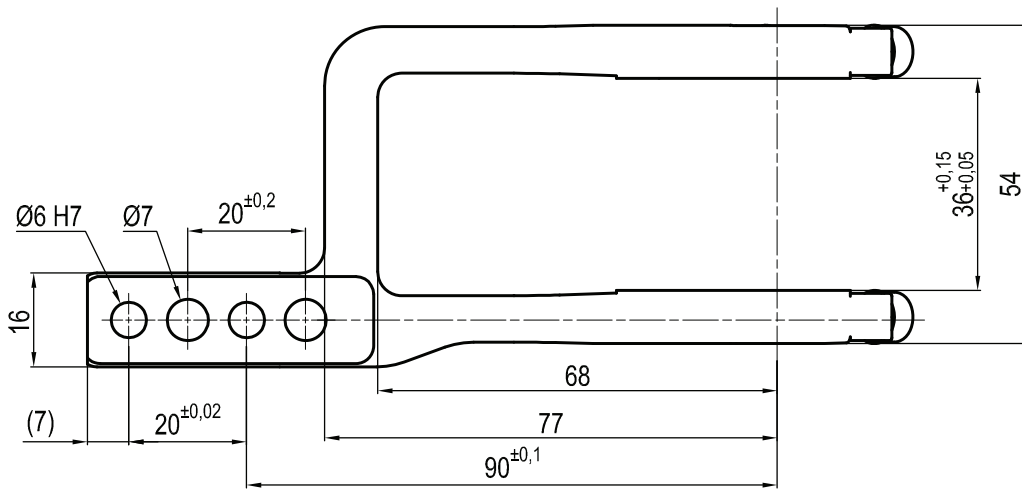
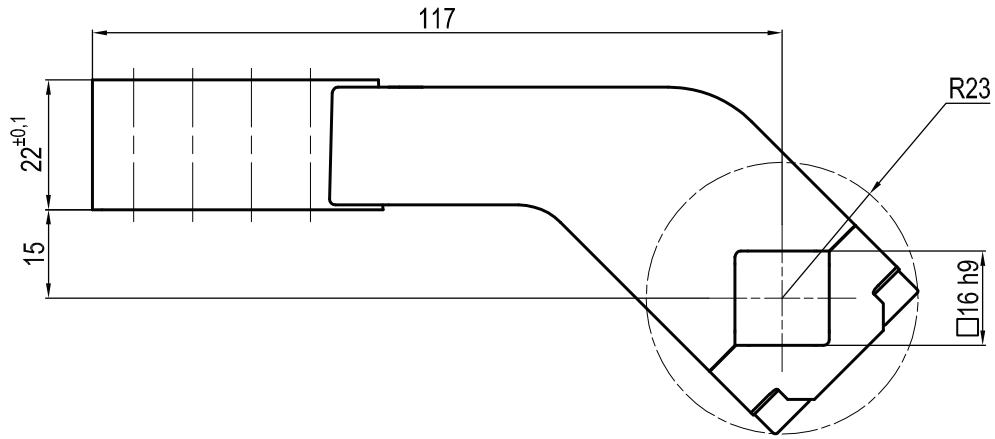

Clamp size	Material	Weight
40 mm	Steel	0,4 Kg

THE CLAMPING ARM INCLUDES THE NECESSARY SCREWS

Subject to technical modifications without notice

Rev. 01 15.01.16

UKP01E

□ 16 mm - offset 45 mm

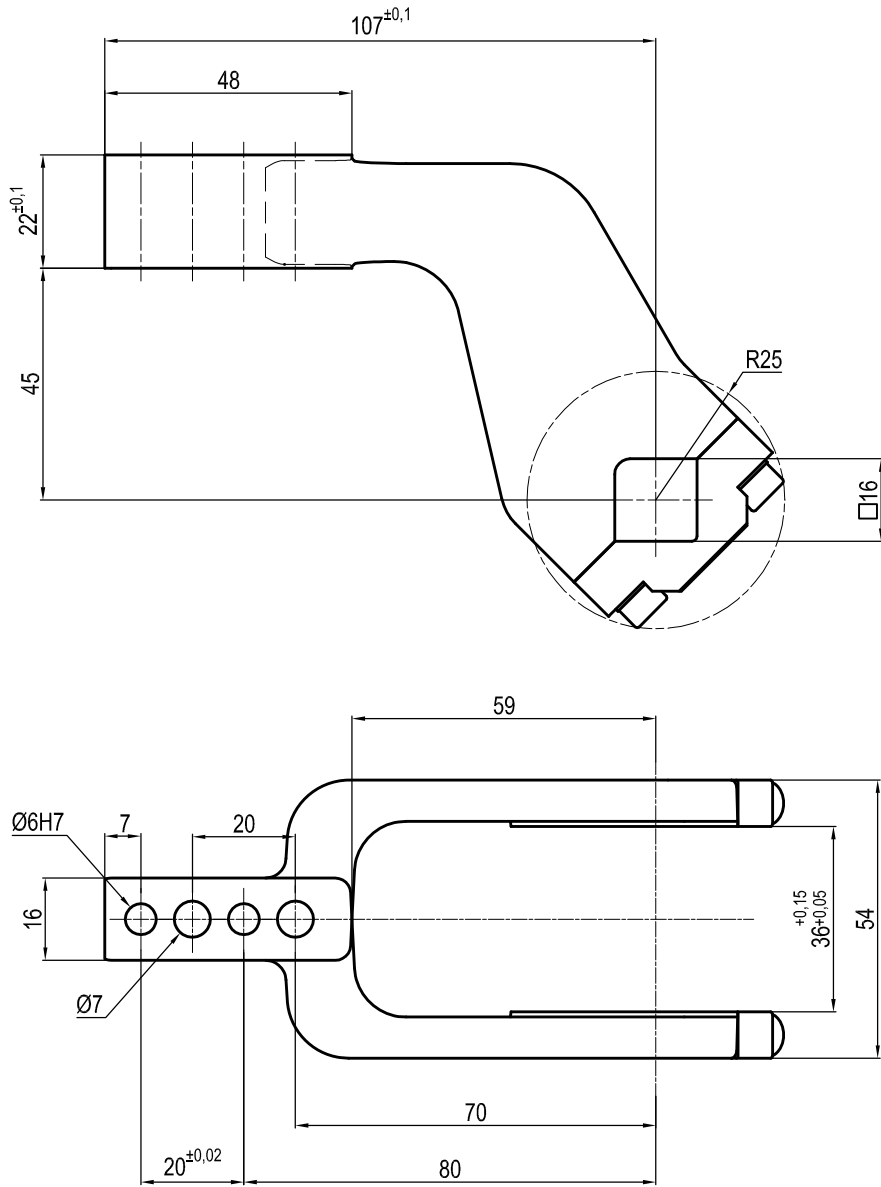

Clamp size	Material	Weight
40 mm	Aluminium	0,25 Kg

THE CLAMPING ARM INCLUDES THE NECESSARY SCREWS

Subject to technical modifications without notice

UKP01F

□ 16 mm - offset 45 mm

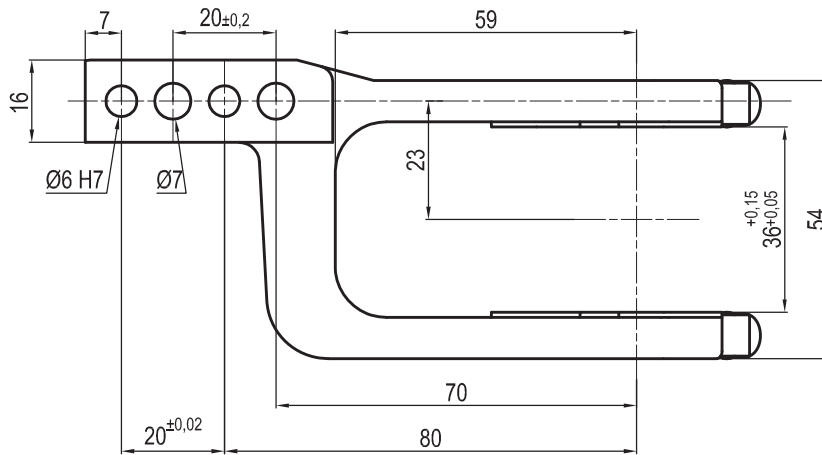
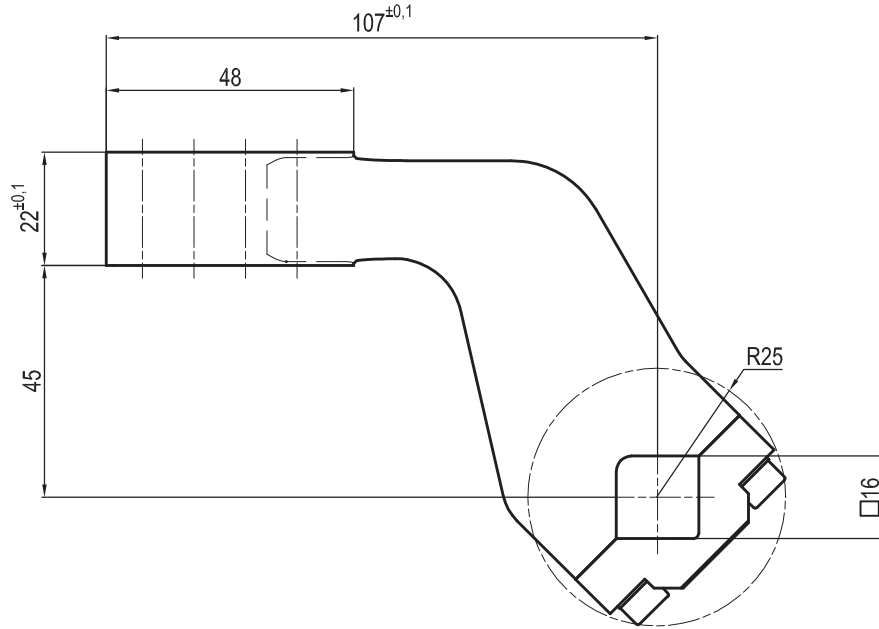

Clamp size	Material	Weight
40 mm	Aluminium	0,25 Kg

THE CLAMPING ARM INCLUDES THE NECESSARY SCREWS

Subject to technical modifications without notice

UKP01L

□ 16 mm - offset 45 mm

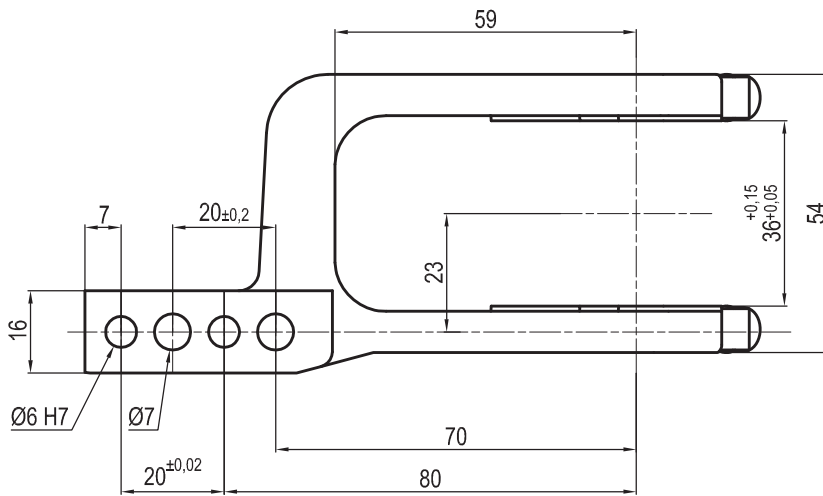
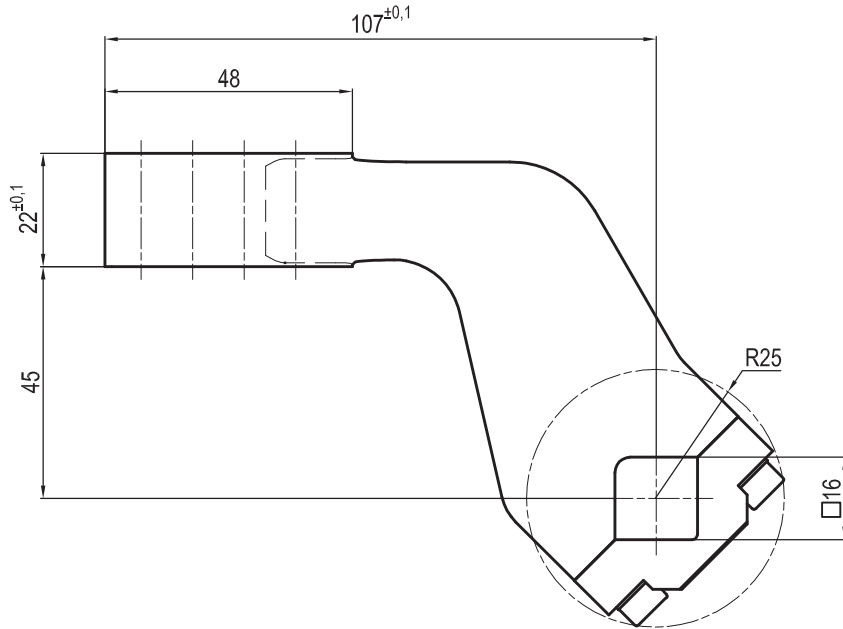

Clamp size	Material	Weight
40 mm	Aluminium	0,25 Kg

THE CLAMPING ARM INCLUDES THE NECESSARY SCREWS

Subject to technical modifications without notice

UKP01ES

□ 16 mm - offset 45 mm

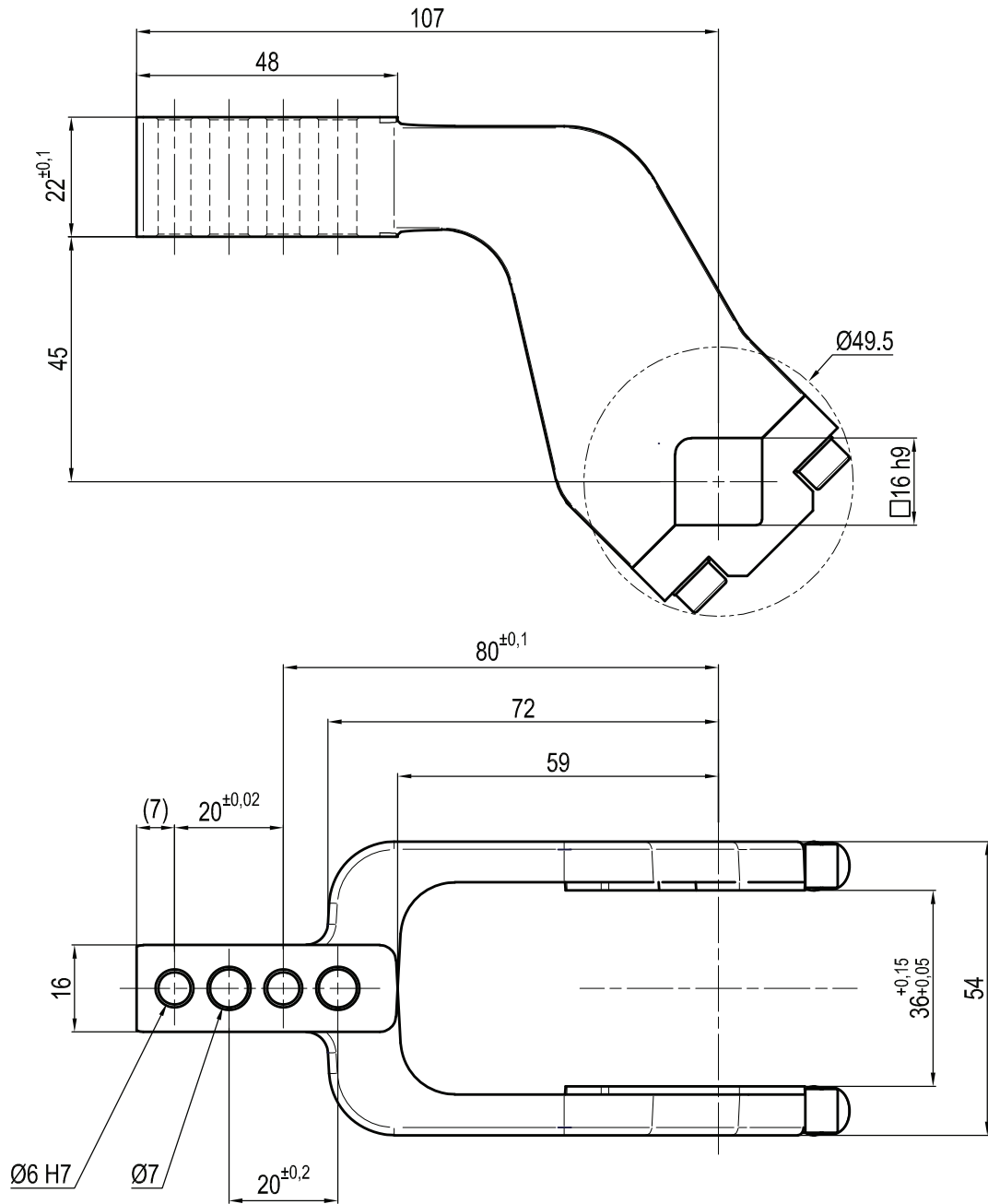

Clamp size	Material	Weight
40 mm	Steel	0,23 Kg

THE CLAMPING ARM INCLUDES THE NECESSARY SCREWS

Subject to technical modifications without notice