

# UBP32

UNIVERSAL Power clamps



U	B	P	3	2	N	N	E
1	2	3	4	5	6		

<b>1 Series</b>	<b>2 Version</b>	<b>3 Size</b>
<p><b>UB = UNIVERSAL</b> Power clamps fully adjustable opening angle:  <b>0° to 135° max</b>                  The opening angle range may vary according to the arm position and style</p>	<p><b>P = Pneumatic-standard</b></p>	<p><b>32 = Ø 32 mm</b></p>

<b>4 Arm position</b>	<b>5 Arm style</b>	<b>6 Sensor</b>
<p><b>V = 90°    O = 180°    N = No arm</b></p>	<p><b>B = Central, 0 mm offset</b>  <b>C = Central, 10 mm offset</b>  <b>N = No arm</b></p>	<p><b>N = No sensor</b>                  (with protection plate)  <b>E = Electronic sensor with M12 swivel connector</b></p>

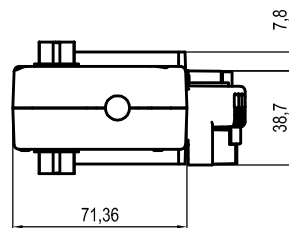
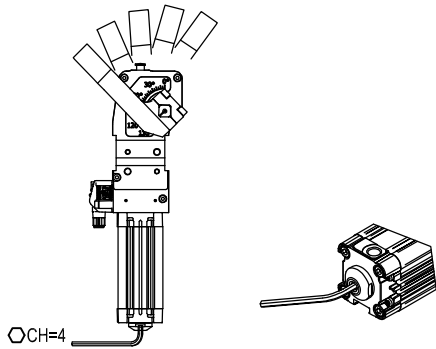
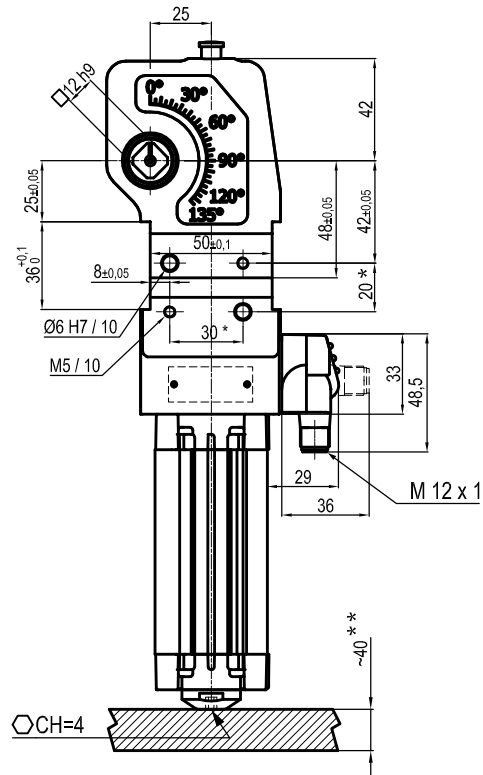
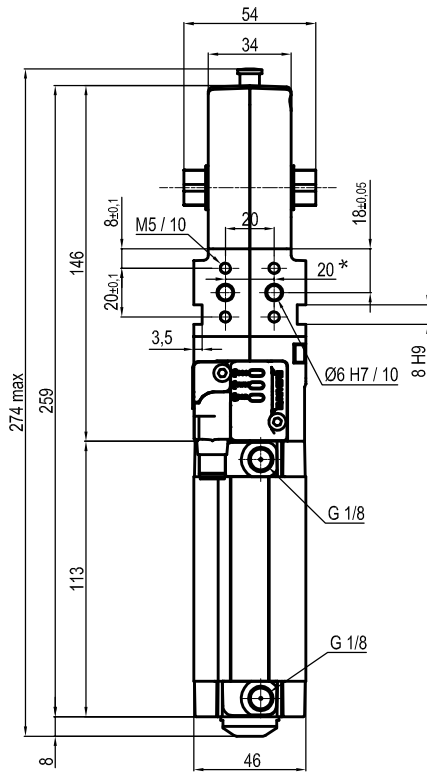

Bore Ø	Holding moment	Clamping moment	Weight (Clamping arm not included)
32 mm	250 Nm	75 Nm	1.3 Kg

Min./Max. operating pressure: **0,4 / 0,8 MPa**

Operating temperature: **5° + 45° C**

Opening angle: **adjustable**

Electronic sensor with M12 swivel connector that can be orientated at 0° or 90°

Supply voltage: 10+30 Vdc

IP code: **IP 65**

Pneumatic ports on both sides

\* : TOLERANCE BETWEEN DOWELS ± 0.02, TO SCREW HOLES ± 0.1

\*\* : AREA TO ACCESS ANGLE ADJUSTMENT

Subject to technical modifications without notice

## UNIVERSAL Pneumatic clamp

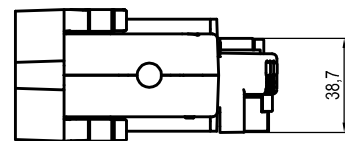
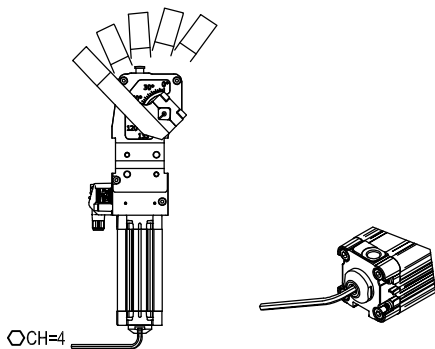
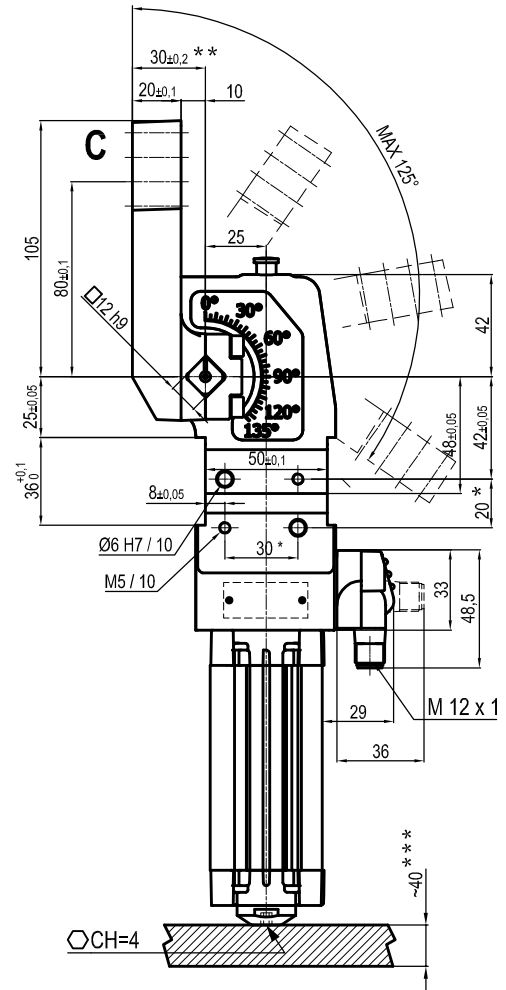
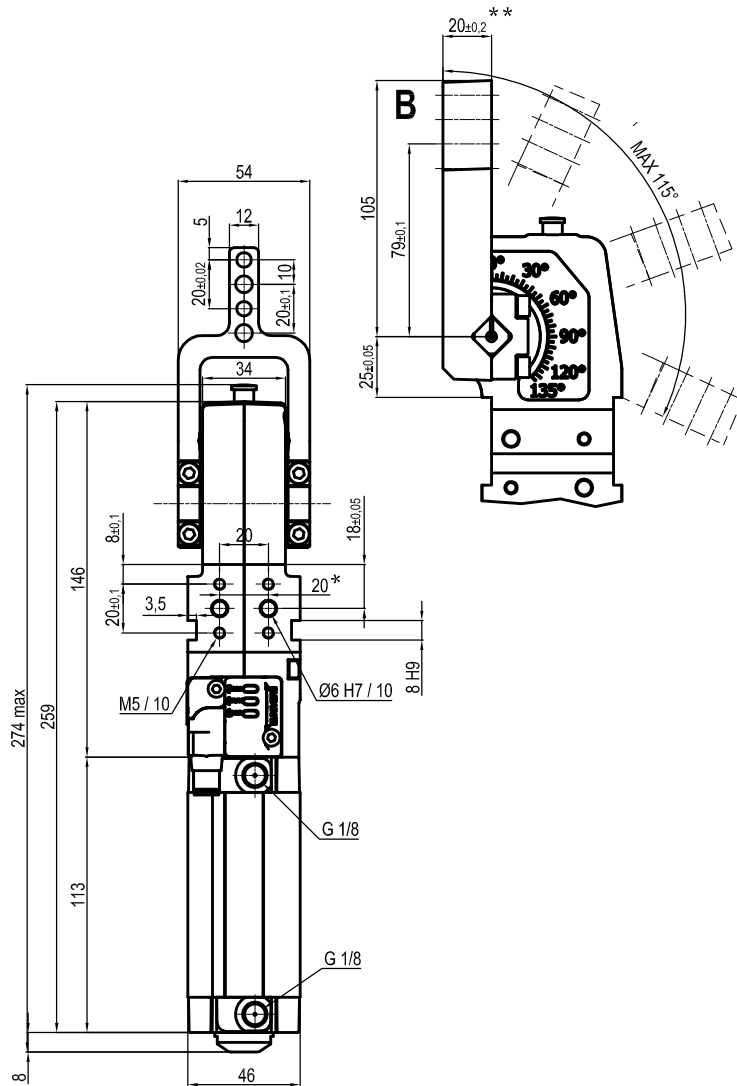

Bore Ø	Holding moment	Clamping moment	Weight (Clamping arm not included)
32 mm	250 Nm	75 Nm	1.3 Kg

Min./Max. operating pressure: 0,4 / 0,8 MPa

Operating temperature: 5° ± 45° C

Opening angle: adjustable from 0° to 125°

Electronic sensor with M12 swivel connector that can be orientated at 0° or 90°

Supply voltage: 10\*30 Vdc

IP code: IP 65

Pneumatic ports on both sides

\* : TOLERANCE BETWEEN DOWELS ± 0.02, TO SCREW HOLES ± 0.1

\*\* : TOLERANCE AT 80 mm FROM PIVOT POINT

\*\*\* : AREA TO ACCES ANGLE ADJUSTMENT

Subject to technical modifications without notice

## UNIVERSAL Pneumatic clamp

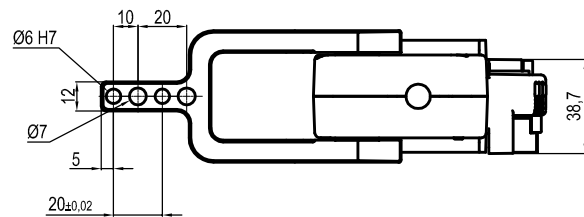
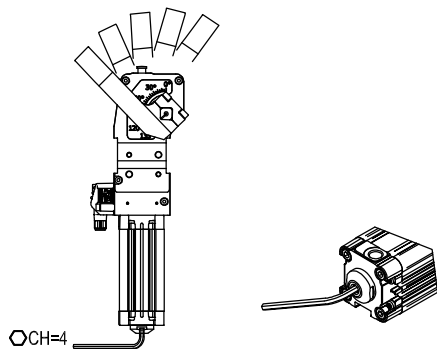
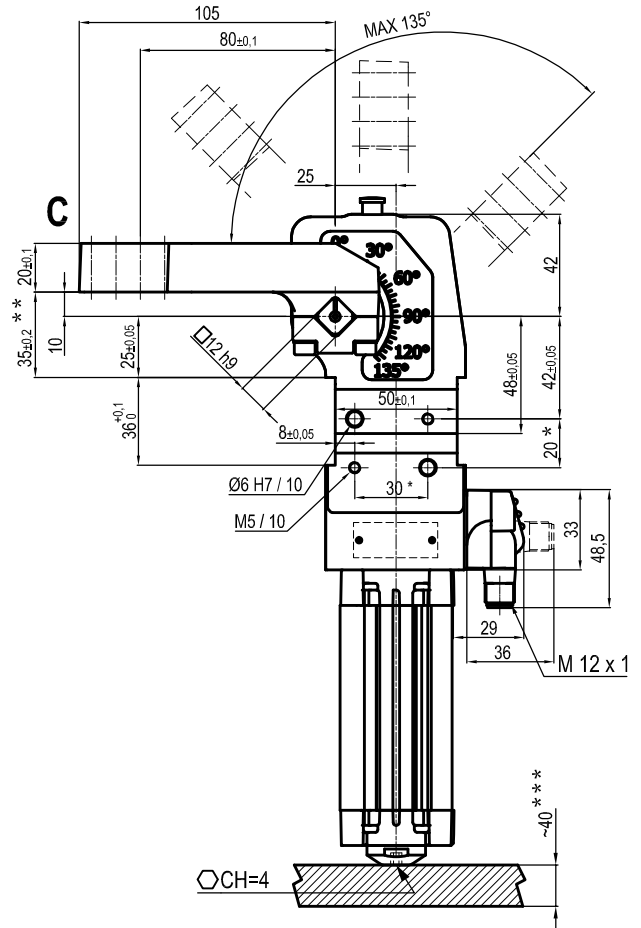
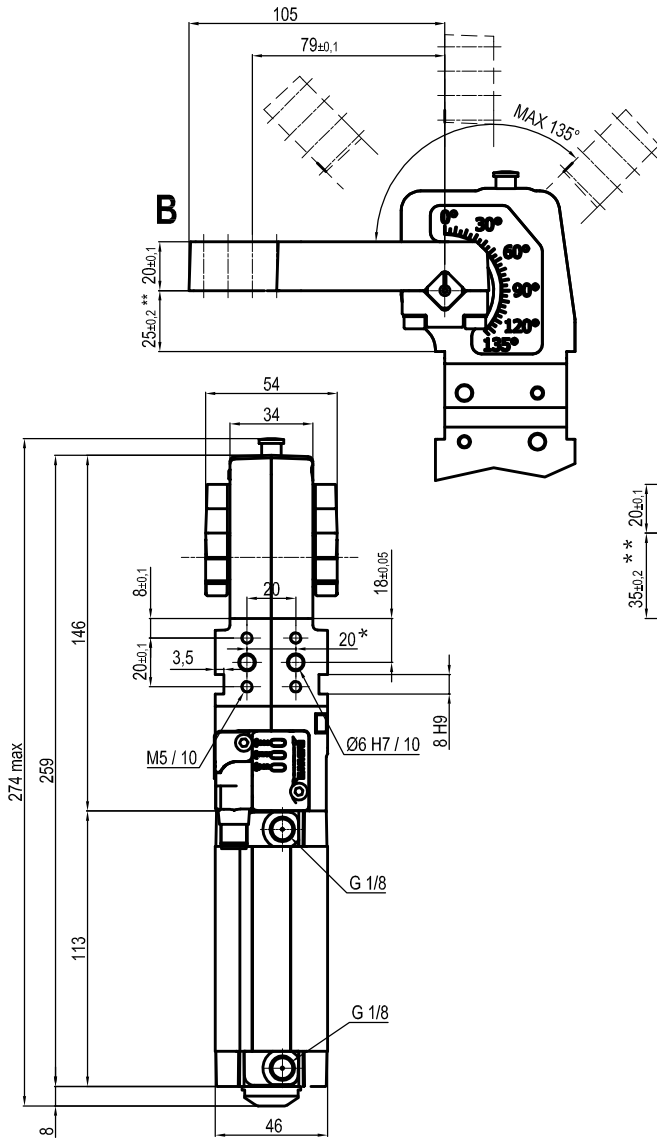

Bore Ø	Holding moment	Clamping moment	Weight (Clamping arm not included)
32 mm	250 Nm	75 Nm	1.3 Kg

Min./Max. operating pressure: 0,4 / 0,8 MPa

Operating temperature: 5° + 45° C

Opening angle: adjustable from 0° to 135°

Electronic sensor with M12 swivel connector that can be orientated at 0° or 90°

Supply voltage: 10+30 Vdc

IP code: IP 65

Pneumatic ports on both sides

\* : TOLERANCE BETWEEN DOWELS ± 0.02, TO SCREW HOLES ± 0.1

\*\* : TOLERANCE AT 80 mm FROM PIVOT POINT

\*\*\* : AREA TO ACCES ANGLE ADJUSTMENT

Subject to technical modifications without notice