

UBM63

UNIVERSAL Power clamps

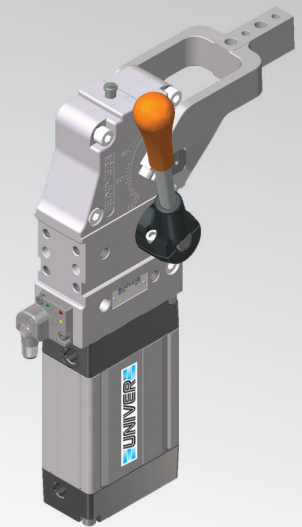

U	B	M	6	3	O	E	K	
1	2	3	4	5	6	7		

1 Series	2 Version	3 Size
----------	-----------	--------

UB = UNIVERSAL Power clamps
fully adjustable opening angle:
0° to 135° Max
The opening angle range may vary
according to the arm position and style

M = Pneumatic with manual lever

63 = Ø 63 mm

4 Arm position	5 Arm style	6 Sensor
----------------	-------------	----------

V = 90° **O** = 180° **N** = No arm

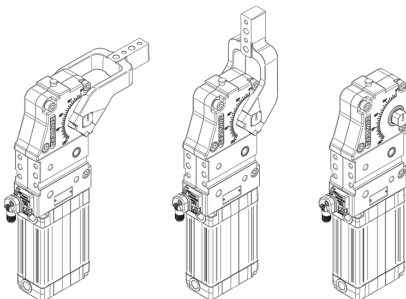

C = Central, 15 mm offset

D = Right, 15 mm offset

S = Left, 15 mm offset

E = Central, 45 mm offset

F = Right, 45 mm offset

L = Left, 45 mm offset

X* = Central, oversized dowel holes Ø 8 H7, 15 mm offset

Y* = Right, oversized dowel holes Ø 8 H7, 15 mm offset

Z* = Left, oversized dowel holes Ø 8 H7, 15 mm offset

T* = Central, oversized dowel holes Ø 8 H7, 45 mm offset

U* = Right, oversized dowel holes Ø 8 H7, 45 mm offset

V* = Left, oversized dowel holes Ø 8 H7, 45 mm offset

N = No arm

***** = Available upon request

N = No sensor

(with protection plate)

K = Electronic sensor PNP (optical)
(DF-K)

D = Pneumatic sensor

7 Arm material

S = Steel

If not specified the aluminium version
is supplied

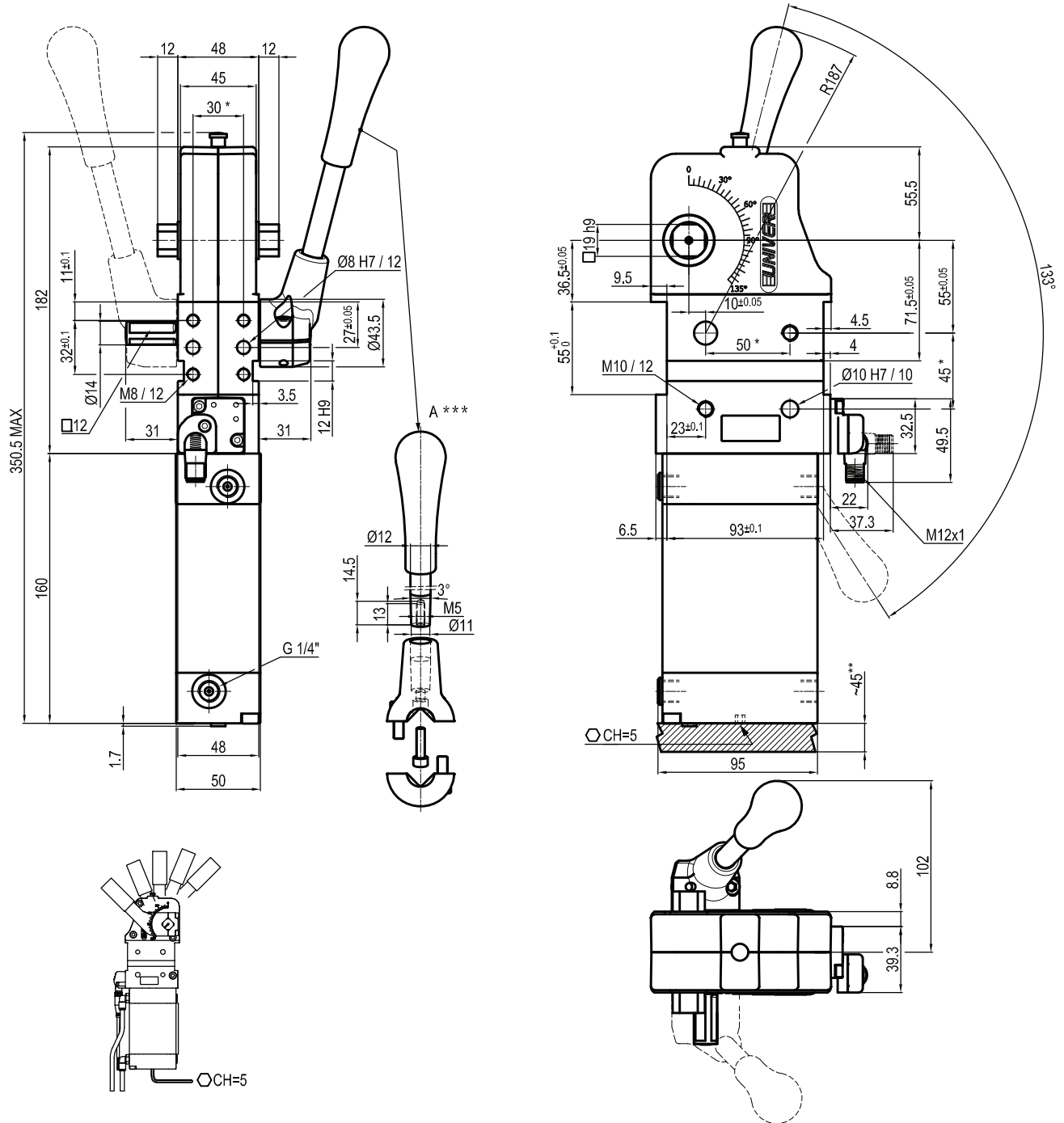
UBM63NNK

Bore Ø	Holding moment	Clamping moment (0,5 MPa)	Weight (clamping arm not included)
63 mm	1750 Nm	420 Nm	3,6 Kg

 Min./Max. operating pressure: **0,4 / 0,6 MPa**

 Operating temperature: **5° ÷ 45° C**

 Opening angle: **adjustable**

Without arm

With manual lever

Electronic sensor with M12 swivel connector, from 0° to 90°

Supply voltage: 10 ÷ 30 Vdc

 IP code: **IP 65**

Pneumatic ports on both sides

*: TOLERANCE BETWEEN DOWELS ± 0,02, BETWEEN SCREW HOLES ± 0,1

**: AREA TO ACCESS ANGLE ADJUSTMENT

***: DIMENSIONS TO BE RESPECTED IN CASE OTHER MANUAL LEVERS ARE USED

Subject to technical modifications without notice

Rev. 00 05.02.20

LKP00CL

□ 19 mm - offset 15 mm

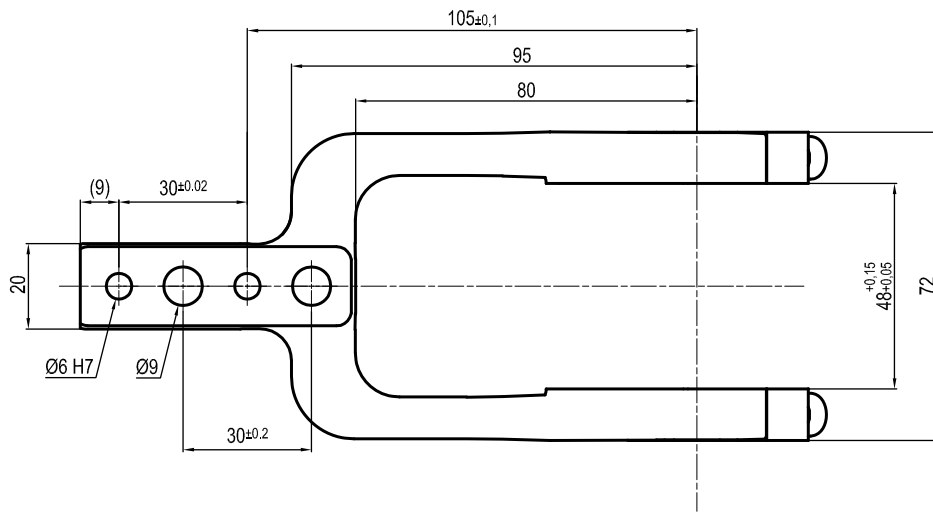
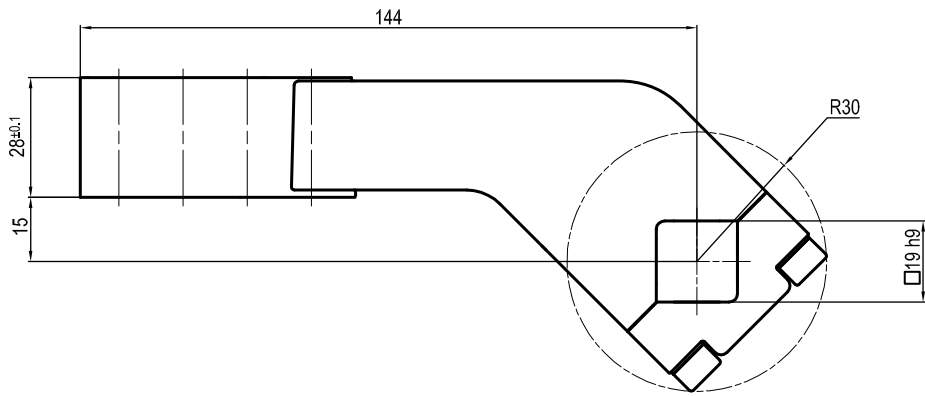

Clamp size	Material	Weight
50/63 mm	Aluminium	0,4 Kg

THE CLAMPING ARM INCLUDES THE NECESSARY SCREWS

Subject to technical modifications without notice

Rev. 01 09.02.16

LKP00DL

□ 19 mm - offset 15 mm

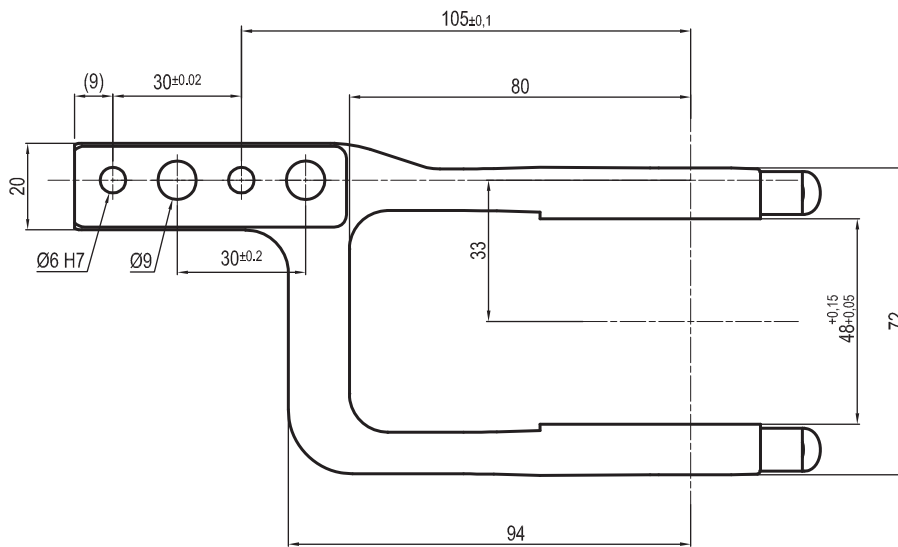
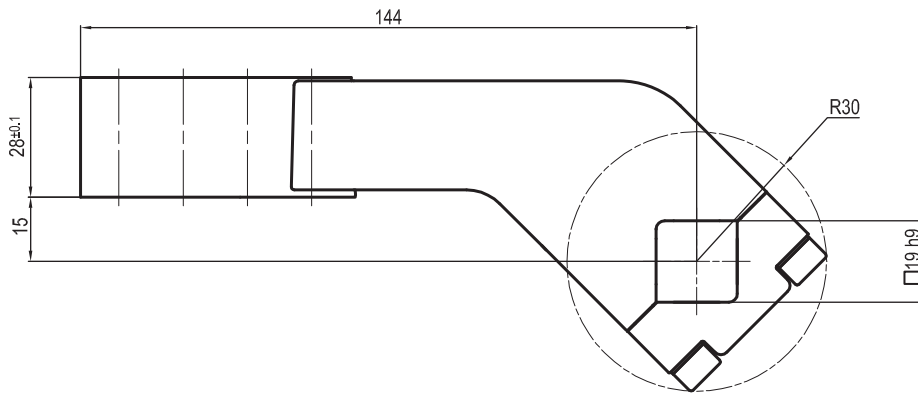

Clamp size	Material	Weight
50/63 mm	Aluminium	0,4 Kg

THE CLAMPING ARM INCLUDES THE NECESSARY SCREWS

Subject to technical modifications without notice

Rev. 02 14.07.16

LKP00SL

□ 19 mm - offset 15 mm

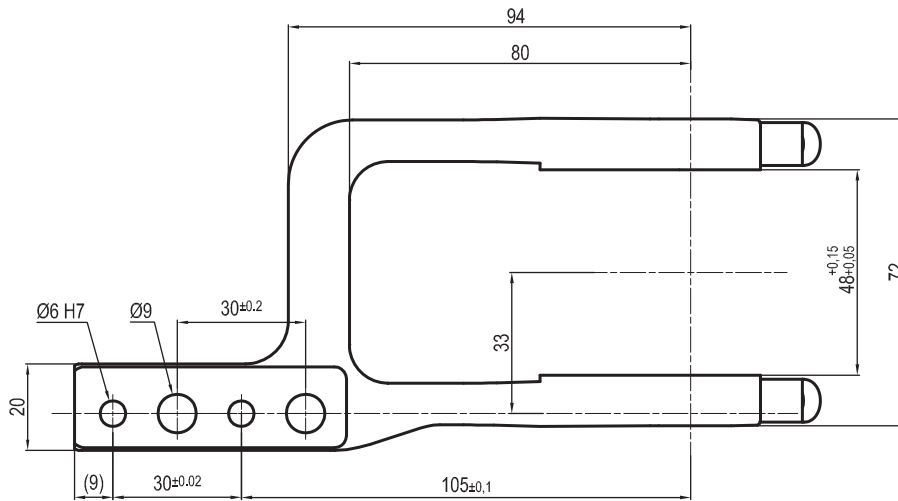
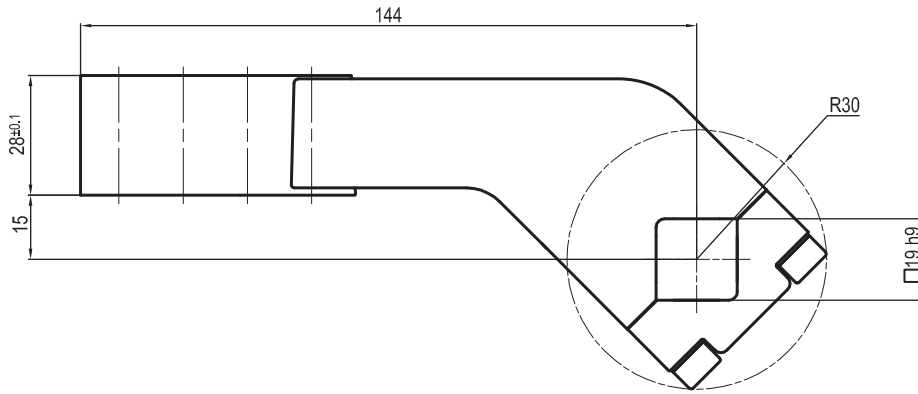

Clamp size	Material	Weight
50/63 mm	Aluminium	0,4 Kg

THE CLAMPING ARM INCLUDES THE NECESSARY SCREWS

Subject to technical modifications without notice

Rev. 02 15.07.16

UP210151441G

□ 19 mm - offset 15 mm

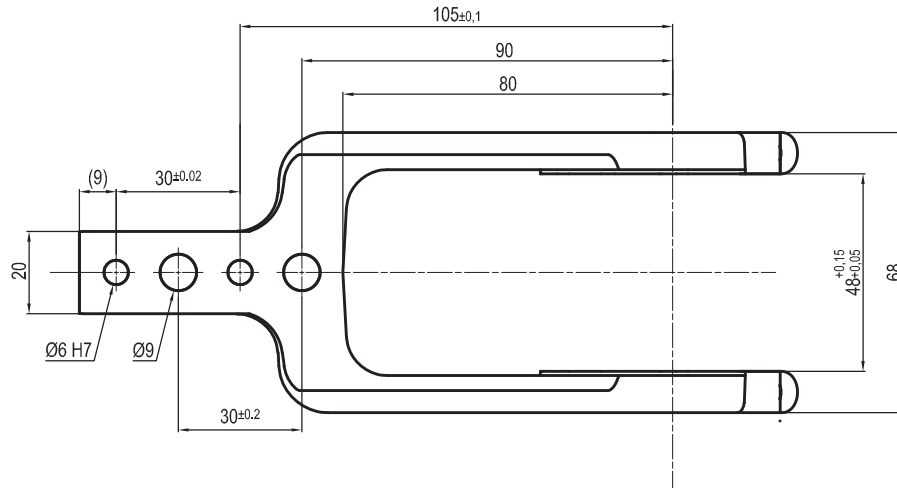
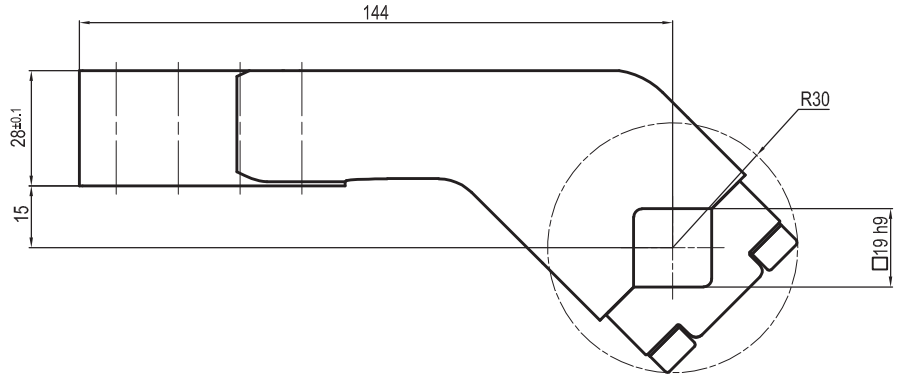

Clamp size	Material	Weight
50/63 mm	Steel	0,8 Kg

THE CLAMPING ARM INCLUDES THE NECESSARY SCREWS

Subject to technical modifications without notice

Rev. 01 15.01.16

UP210151442G

□ 19 mm - offset 15 mm

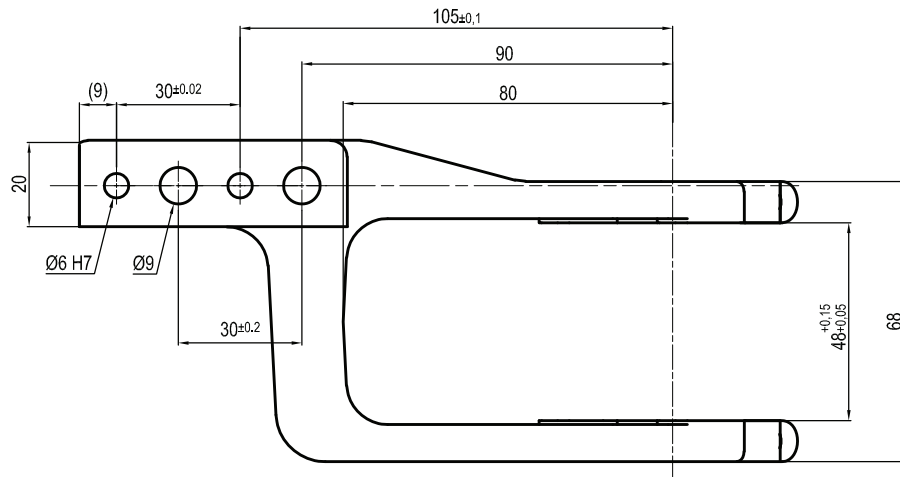
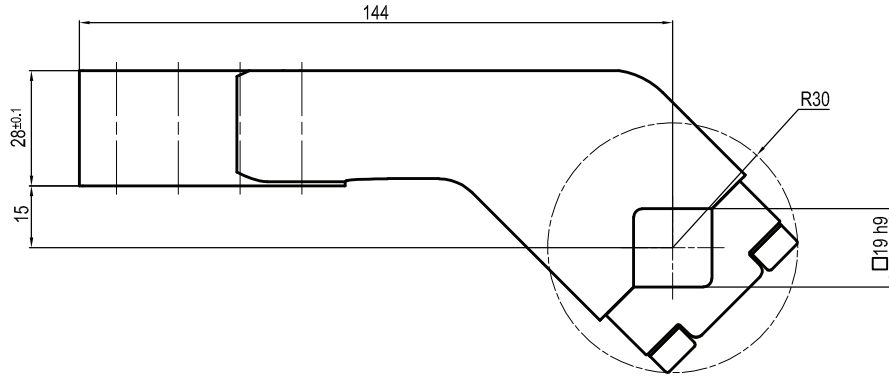

Clamp size	Material	Weight
50/63 mm	Steel	0,8 Kg

THE CLAMPING ARM INCLUDES THE NECESSARY SCREWS

Subject to technical modifications without notice

Rev. 01 15.01.16

UKP5063E

□ 19 mm - offset 45 mm

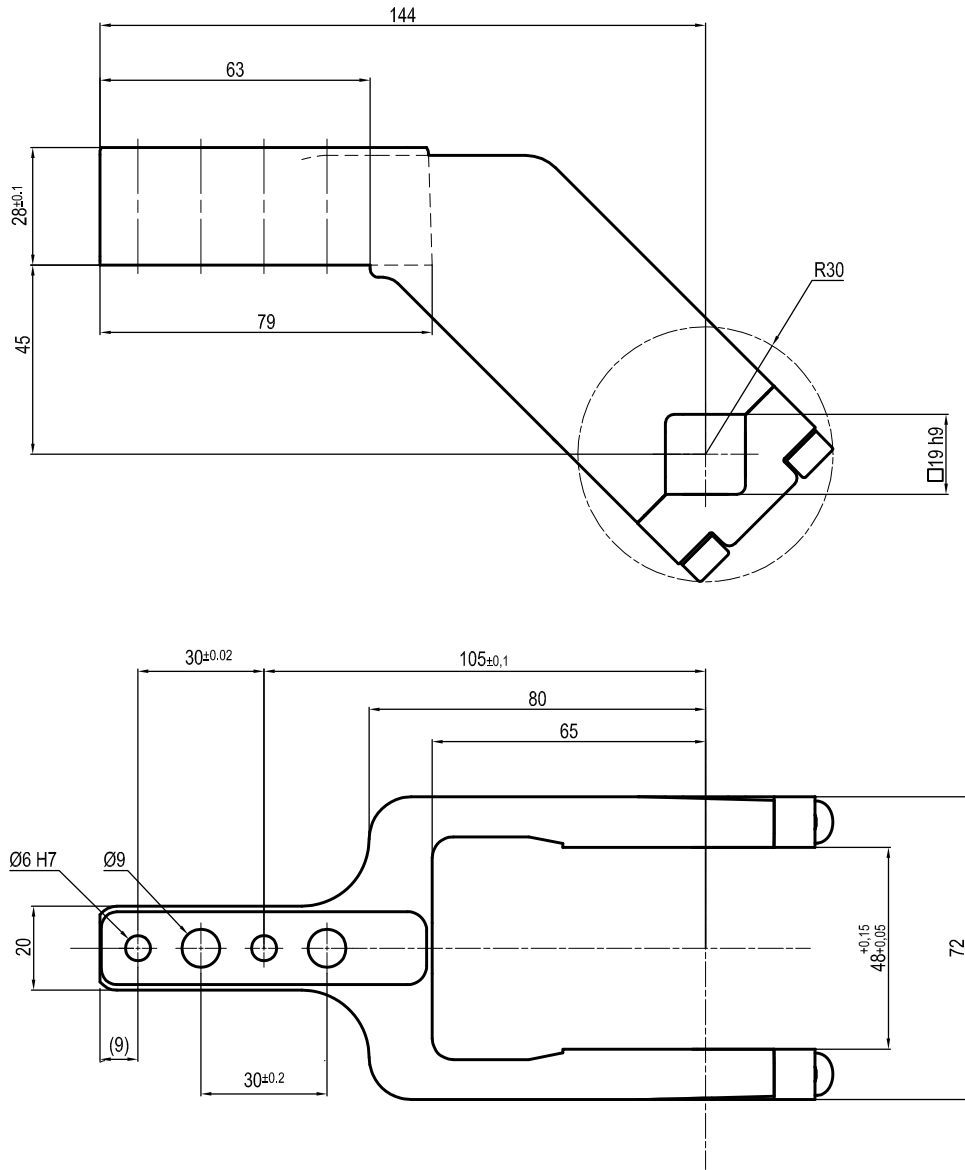

Clamp size	Material	Weight
50/63 mm	Aluminium	0,45 Kg

THE CLAMPING ARM INCLUDES THE NECESSARY SCREWS

Subject to technical modifications without notice

UKP63F

□ 19 mm - offset 45 mm

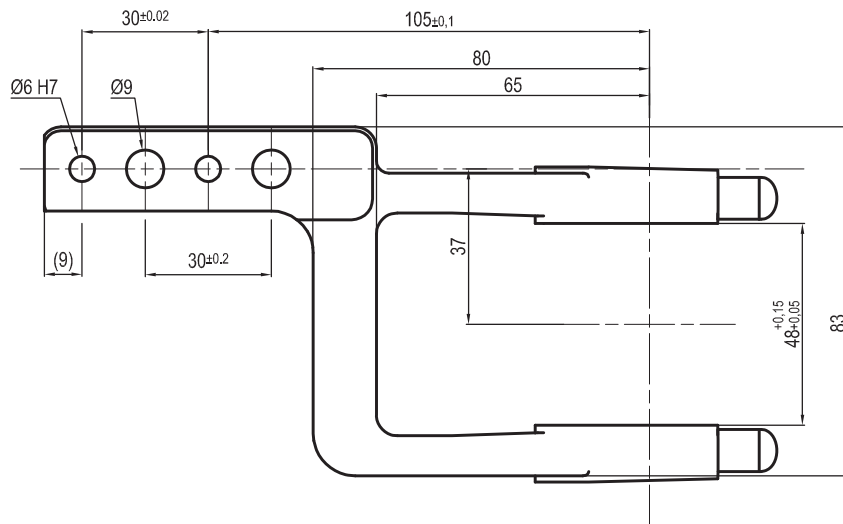
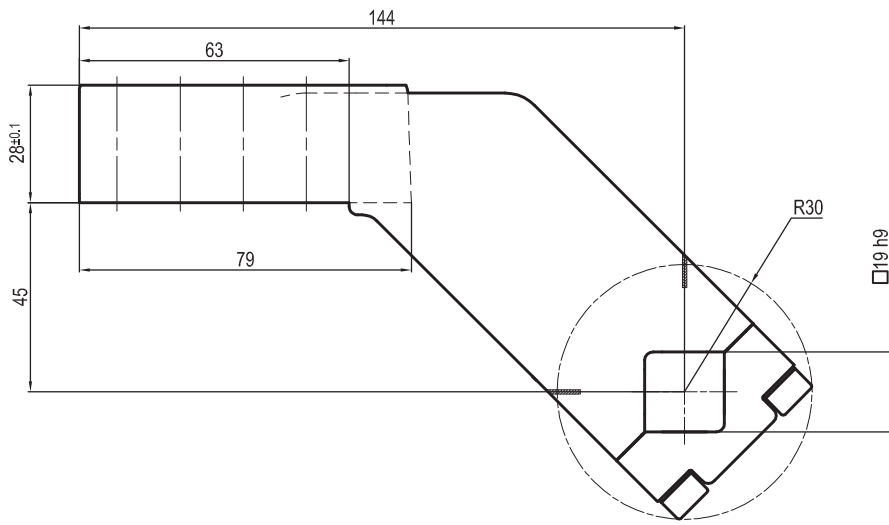

Clamp size	Material	Weight
63 mm	Aluminium	0,45 Kg

THE CLAMPING ARM INCLUDES THE NECESSARY SCREWS

Subject to technical modifications without notice

UKP63L

□ 19 mm - offset 45 mm

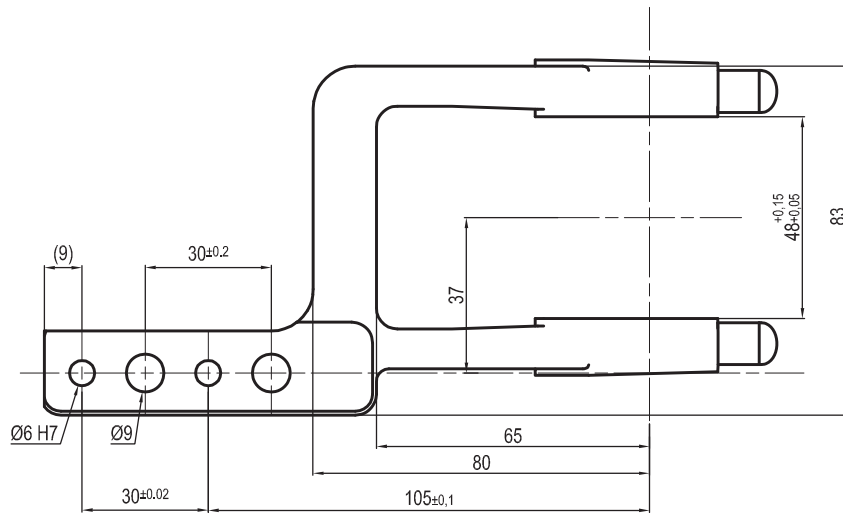
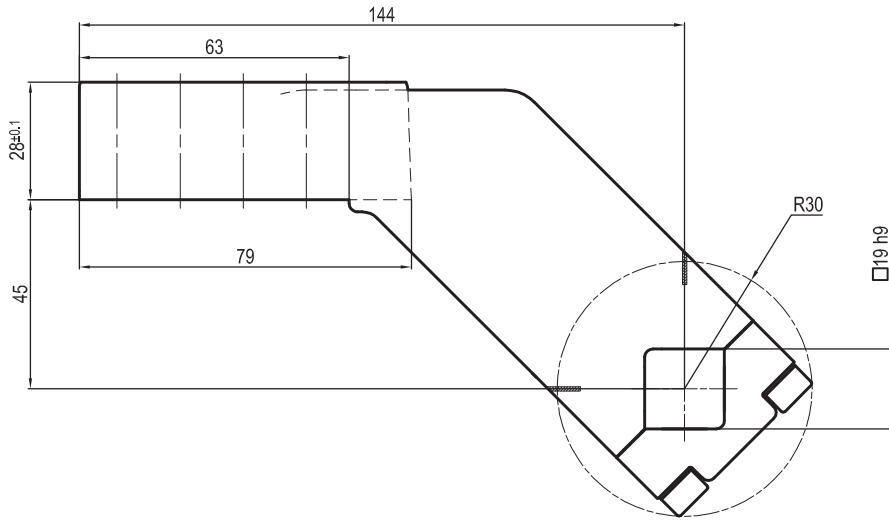

Clamp size	Material	Weight
63 mm	Aluminium	0,45 Kg

THE CLAMPING ARM INCLUDES THE NECESSARY SCREWS

Subject to technical modifications without notice

Rev. 01 15.07.16

UKP5063ES

□ 19 mm - offset 45 mm

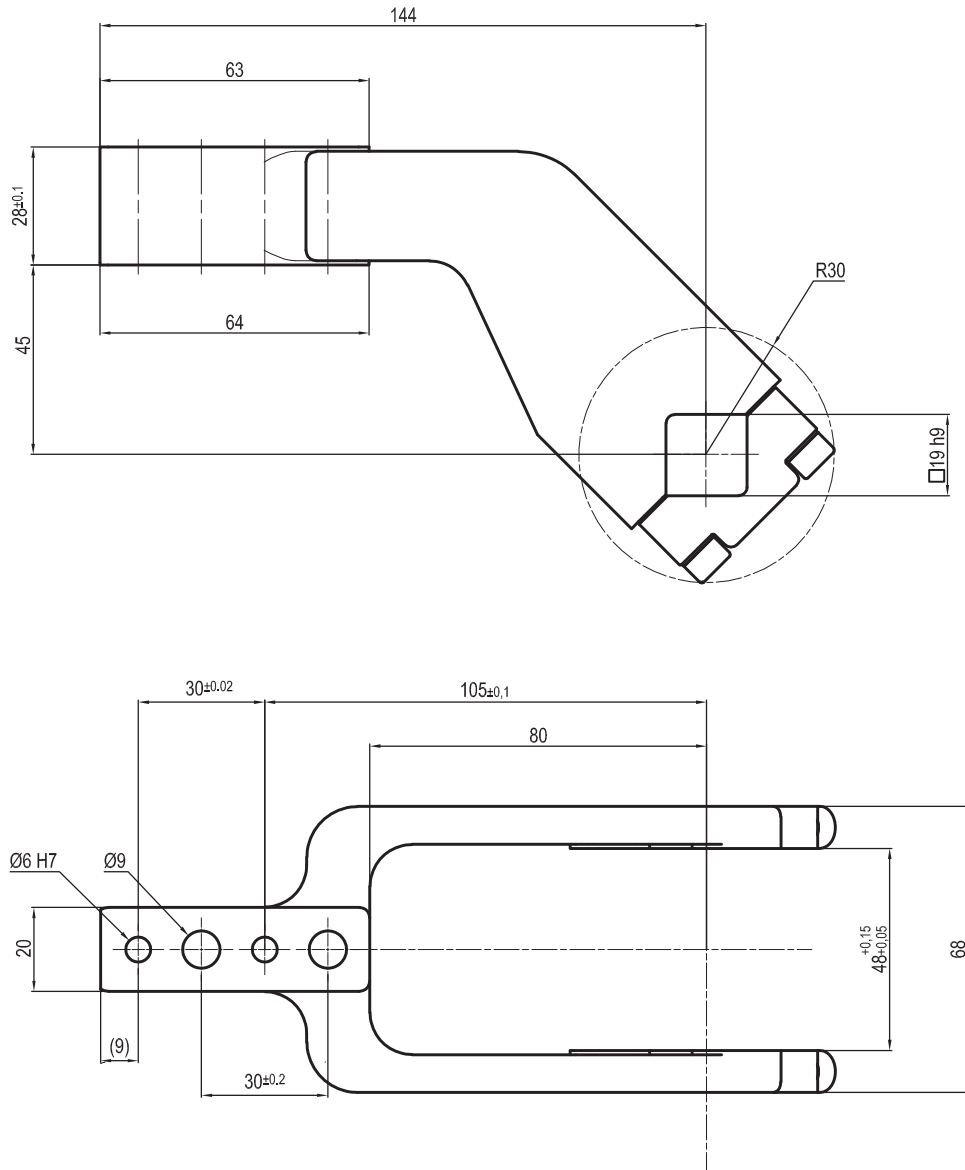

Clamp size	Material	Weight
50/63 mm	Steel	0,92 Kg

THE CLAMPING ARM INCLUDES THE NECESSARY SCREWS

Subject to technical modifications without notice

UKP63FS

□ 19 mm - offset 45 mm

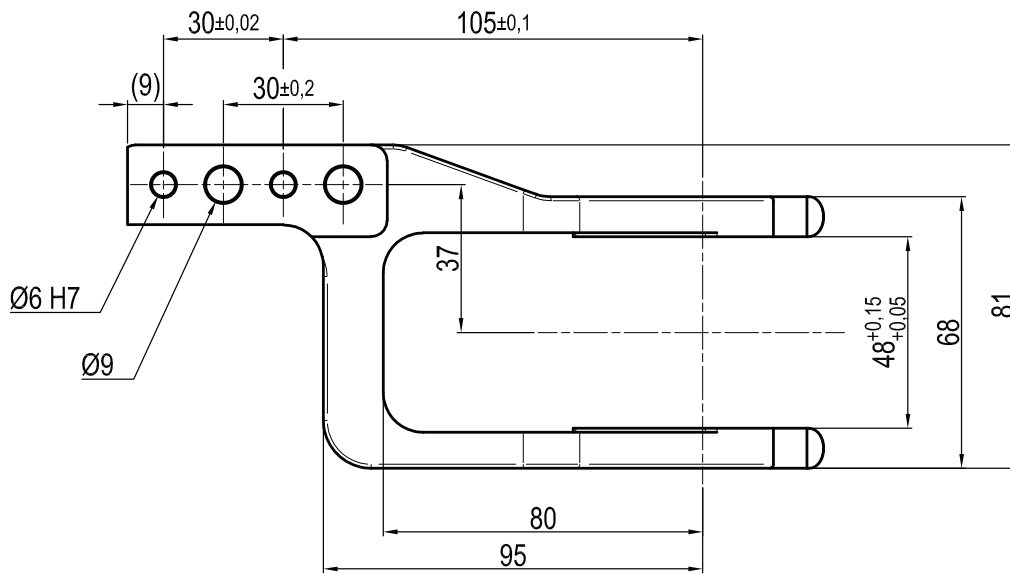
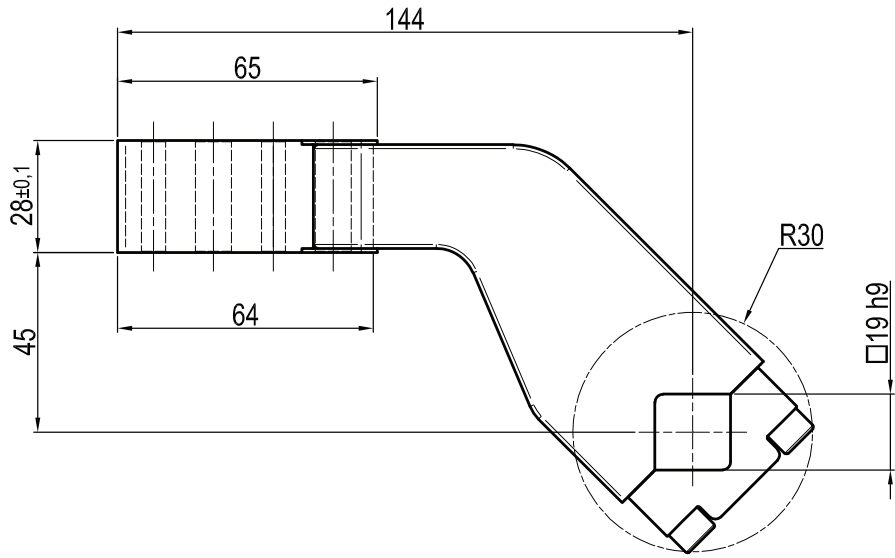

Clamp size	Material	Weight
63 mm	Steel	1,2 Kg

THE CLAMPING ARM INCLUDES THE NECESSARY SCREWS

Subject to technical modifications without notice

Rev. 00 24.07.20

UKP63LS

□ 19 mm - offset 45 mm

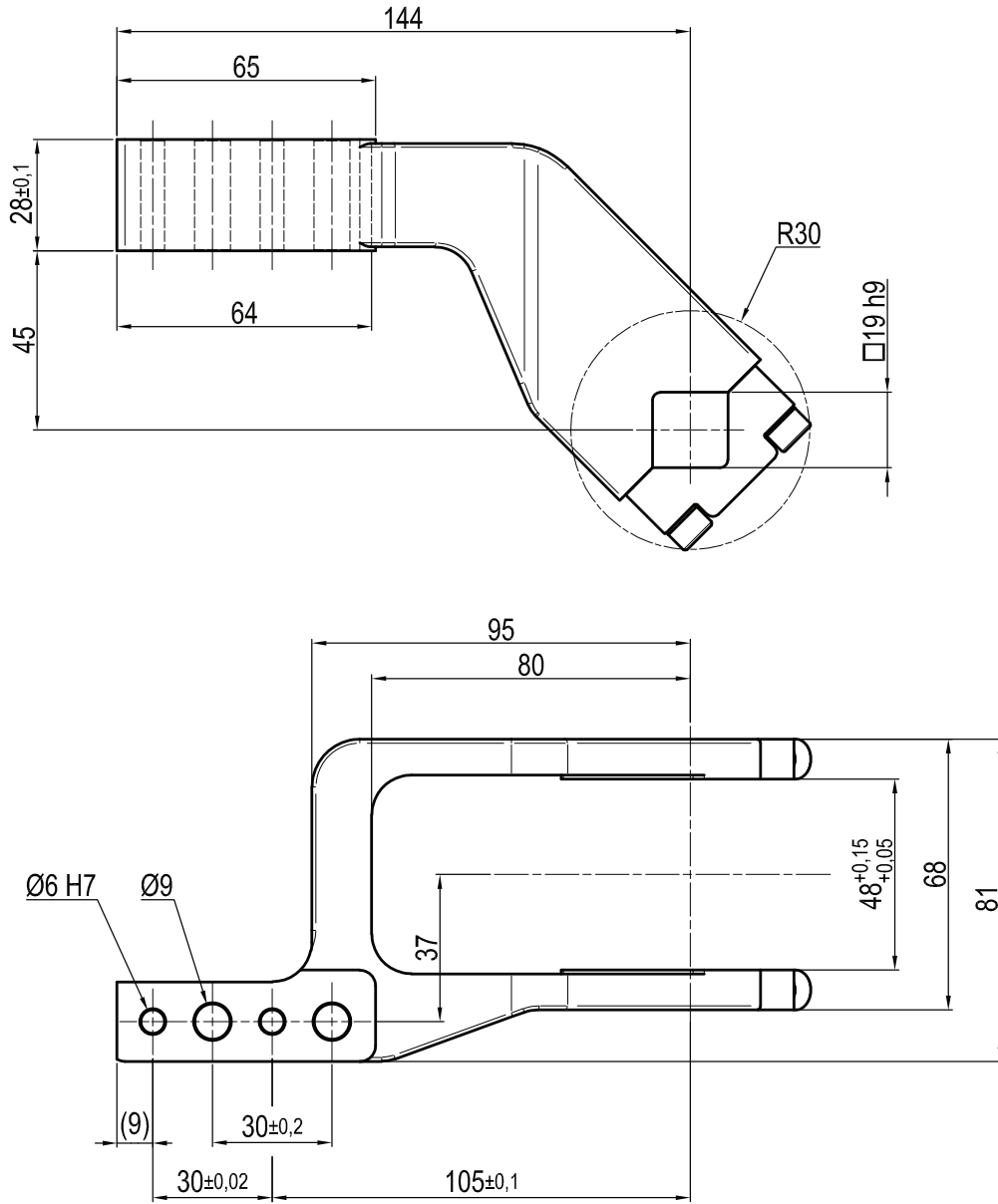

Clamp size	Material	Weight
63 mm	Steel	1,2 Kg

THE CLAMPING ARM INCLUDES THE NECESSARY SCREWS

Subject to technical modifications without notice

Rev. 00 24.07.20