

YR2

Rotary Actuators for Process Automation

- Pneumatic connections configuration: **NAMUR interface - VDI/VDE 3845**
- Top pinion: **VDI/VDE 3845**
- Holes for sensor box connection: **VDI/VDE 3845**
- Bottom holes for connecting valves: **ISO 5211 - DIN 3337**
- Single acting actuators available (2-3-4-5-6 springs)

Standard supplied ATEX version



TECHNICAL CHARACTERISTICS

Ambient temperature	-20° ÷ 80 °C
Fluid	filtered air, with or without lubrication, neutral gases
Working pressure	single acting: 4 ÷ 8 bar double acting: 2 ÷ 8 bar
Connections ^(A)	NAMUR interface (G1/4)
Rotation	0 - 90° ± 3° (external regulation)
Max pressure	10 bar

CONSTRUCTIVE CHARACTERISTICS

End-caps	die-cast aluminium
Piston	die-cast aluminium
Guide slide	acetalic resin
Piston seal	nitrile rubber (NBR)
Body	hard anodized aluminum extrusion
Pinion	nickel plated steel
Screws and nuts	stainless steel

CODIFICATION KEY

Y	R	2	0	1	D	A	0
1		2			3		

1 Series	2 Size (mm)	3 Version
YR2 = Rotary Actuators for Process Automation	00 = 32 mm (DA0 only) 01 = 50 mm 2A = 63 mm (F04) 2B = 63 mm (F05) 03 = 75 mm 35 = 85 mm 04 = 100 mm 45 = 115 mm 05 = 125 mm 55 = 145 mm 06 = 160 mm 08 = 200 mm 10 = 250 mm	DA0 = Double acting S12 = Single acting 12 springs standard (different number of springs upon request)

(A) = bottom hole for ball valve installation in compliance with ISO 5211/DIN 3337 standards.
Solenoid valve interface, shaft top-end and top hole for accessory fixing in compliance with VDI/VDE 3845 NAMUR standards.

Functioning

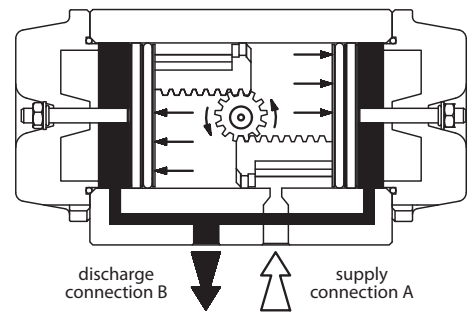

Opening movement of pistons, anticlockwise rotation when supplying to connection A

Weight (Kg)

	YR200	YR201	YR22A/2B	YR203	YR235	YR204	YR245	YR205	YR255	YR206	YR208	YR210
Single acting	-	1,27	1,85	3,36	4,81	6,92	9,72	14,15	17,35	25,90	48,62	101
Double acting	0,58	1,15	1,60	2,80	4,28	5,80	8,26	11,63	14,15	21,70	40,10	77

Opening and closing time at 5,6 bar (sec)

	YR200	YR201	YR22A/2B	YR203	YR235	YR204	YR245	YR205	YR255	YR206	YR208	YR210
Single acting	-	1 Max	1 Max	1 Max	1,5 Max	1,5 Max	1 Max	1,5 ÷ 2	2 Max	2 ÷ 3	4 ÷ 6	7 ÷ 8
Double acting	0,5 Max	1 Max	1 Max	1 Max	1 Max	1 Max	1 Max	1,25 Max	1,5 Max	1,5 ÷ 2	3 ÷ 4	5 ÷ 6

Air consumption for stroke (l)

	YR200	YR201	YR22A/2B	YR203	YR235	YR204	YR245	YR205	YR255	YR206	YR208	YR210
Opening	0,04	0,08	0,12	0,24	0,48	0,68	1	1,4	1,6	3,2	5,3	14,2
Closing	0,05	0,1	0,16	0,44	0,56	0,96	1,6	2,16	2,56	4	8,6	16,5

Torque output double acting actuators (Nm)

	Working pressure (bar)							
	2	3	4	5	6	7	8	
YR200DA0	2,4	3,6	4,8	6	7,3	8,5	9,7	
YR201DA0	5,9	8,9	11,8	14,8	17,7	21,7	24,8	
YR224DA0-YR22BDA0	9,4	14,1	18,8	23,5	28,2	32,9	37,6	
YR203DA0	20	30	40	50	60	70	80	
YR235DA0	34	51	68	85	102	119	136	
YR204DA0	48	71	95	119	142	168	192	
YR245DA0	87,2	130,8	174,4	218	261,6	305,2	348,8	
YR205DA0	111	167	222	278	333	388,5	444	
YR255DA0	157,6	236,4	315,3	394,1	473	551,8	630,6	
YR206DA0	227	340	454	567	680	794,5	908	
YR208DA0	428	638	851	1064	1276	1491	1704	
YR210DA0	1078	1617	2156	2695	3234	3773	4312	

Torque output single acting actuators (Nm)

	Working pressure (bar)									
	4		5		6		7		8	
	0°	90°	0°	90°	0°	90°	0°	90°	0°	90°
YR201S12	-	-	7,6	4,3	10,5	7,2	14,5	11,2	17,6	14,3
YR224S12-YR22BS12	-	-	12,1	6,7	16,8	11,4	21,5	16,1	26,2	20,8
YR203S12	-	-	26	14	36	24	46	34	56	44
YR235S12	-	-	47	22	64	39	81	56	106,4	73
YR204S12	-	-	64	33	87	56	113	82	137	88,8
YR245S12	72,4	14,4	116	58	159,6	101,6	203,2	145,2	246,8	188,8
YR205S12	-	-	148	75	203	130	258,5	185,5	314	241
YR255S12	145,3	15,3	224,1	94,1	303	173	381,8	241,8	460,6	330,6
YR206S12	-	-	316	147	429	260	543,5	374,5	657	488
YR208S12	-	-	584	308	796	520	1011	735	1224	948
YR210S12	-	-	-	-	1909	1254	2448	1793	2987	2332

- The torque of the actuator must not be lower than the torque needed by the valve.
- The torque needed by the valve is increased by 25% as a safety coefficient

YR200

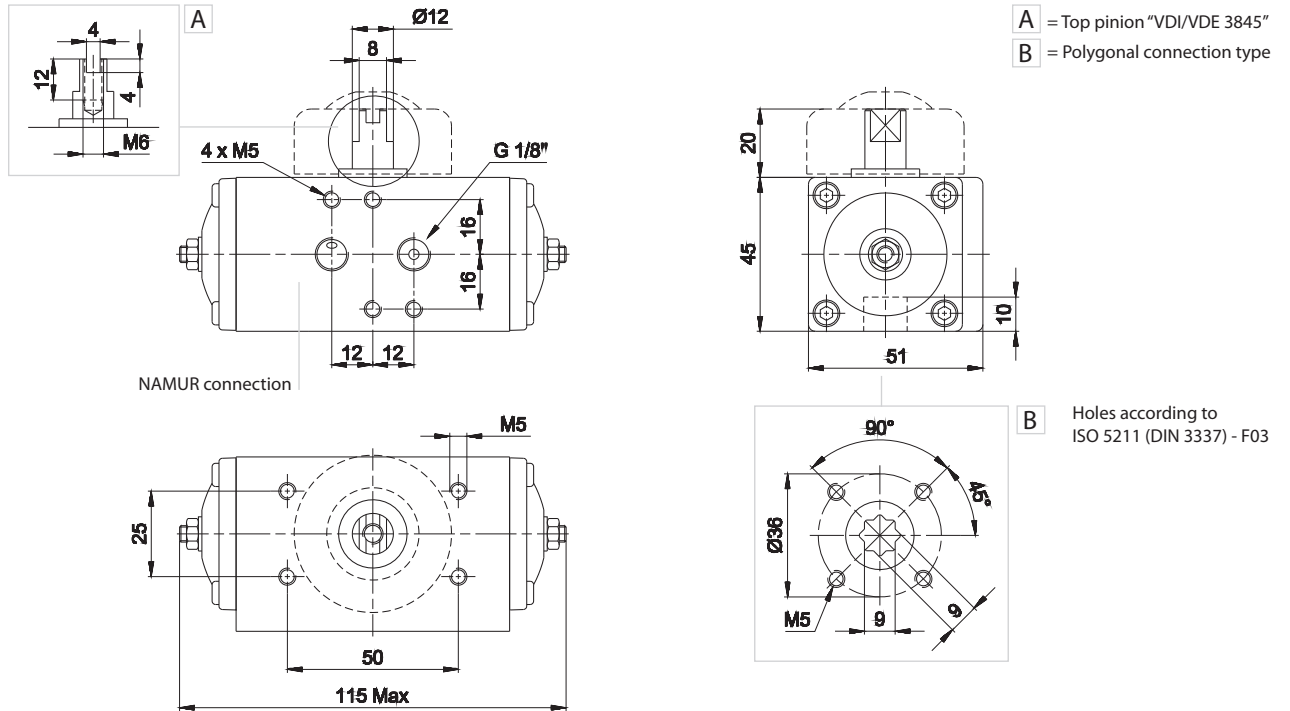

YR2_ _

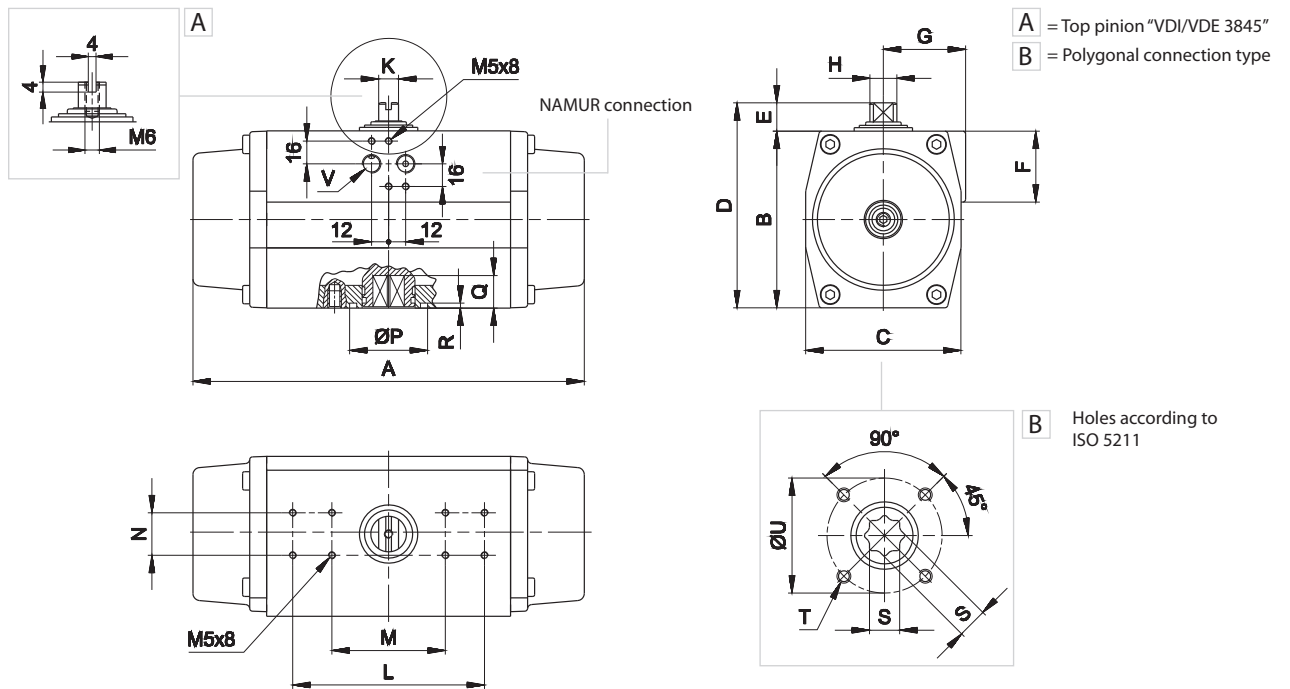

	A	B	C	D	E	F	G	H	K	L	M	N	P	Q	R	S	T	U	V	ISO 5211
YR201	142	67	60	87	20	42	41	12	8	-	80	30	25	10	2	9	M5/M6	36/50	G1/8	F03/F05
YR22A	155	83	73	103	20	42	44,5	12	8	-	80	30	30	12	2	11	M5	42	G1/4	F04
YR22B	155	83	73	103	20	42	44,5	12	8	-	80	30	35	12	2	11	M6	50	G1/4	F05
YR203	213	100	85	120	20	50	49,5	14	10	-	80	30	35	16	3	14	M6/M8	50/70	G1/4	F05/F07
YR235	236	110	98	130	20	50	53	19	14	-	80	30	55	20	3,5	17	M/8	70	G1/4	F07
YR204	276	125	110	145	20	50	58	19	14	-	80	30	55	20	3,5	17	M8/M10	70/102	G1/4	F07/F10
YR245	310	142	128	172	30	58	69	28	20	130	80	30	70	24	3,5	22	M10	102	G1/4	F10
YR205	366	155	140	185	30	-	-	28	20	130	80	30	70	24	3,5	22	M10	102	G1/4	F10
YR255	388	176	160	206	30	-	-	36	28	130	80	30	85	29	3,5	27	M12	125	G1/4	F12
YR206	468	200	175	230	30	-	-	36	28	130	80	30	85	29	3,5	27	M12	125	G1/4	F12
YR208	563	250	215	300	50	-	-	48	32	130	-	30	100	38	5	36	M16	140	G1/4	F14
YR210	750	335	290	385	50	-	-	48	32	130	-	30	130	50	5	46	M20	165	G1/4	F16