

# R

## Ø 32 ÷ 125 mm - Pneumatic Rotary Actuators

The rotating action pneumatic cylinders are thought to transform a linear motion to a circular motion with standard or customized angles of rotation. Made of proved components, they include the backlash recovery of the rack and the rotating pignon supported by ball-bearing, making these units ideal to be used in the most demanding applications.

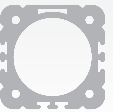

### TECHNICAL CHARACTERISTICS

Ambient temperature	-20 ÷ 80 °C
Fluid	filtered air, with or without lubrication
Working pressure	1,5 ÷ 10 bar
Bores	Ø 32 - 40 - 50 - 63 - 80 - 100 - 125 mm
Cushionings	adjustable in both sides

### CONSTRUCTIVE CHARACTERISTICS

End-caps	die-cast aluminium (painted)
Barrel	anodize aluminium
Piston	die-cast aluminium
Guide slide	acetalic resin
Rack	steel
Piston seal	double-lip nitril rubber (NBR)
Pinion	nitrided steel
Shock absorber seals	nitrile rubber (NBR) on both sides
Magnet	plasto-ferrite

### CODIFICATION KEY

R	1	1	0	3	2	1	8	0	
1	2	3	4	5					

1 Series	2 Type	3 Bore (mm)
R = Ø 32÷125 mm Pneumatic rotary actuators	<b>11</b> = Male pinion without adjustment (degree of accuracy ± 3°) <b>12</b> = Male pinion with adjustment ± 5° <b>13</b> = Female pinion without adjustment (degree of accuracy ± 3°) <b>14</b> = Female pinion with adjustment ± 5°	<b>032</b> = Ø32 <b>040</b> = Ø40 <b>050</b> = Ø50 <b>063</b> = Ø63 <b>080</b> = Ø80 <b>100</b> = Ø100 <b>125</b> = Ø125

4 Angle of rotation	5 Magnetic
<b>090</b> = 90° <b>180</b> = 180° <b>270</b> = 270° <b>360</b> = 360°	<b>M</b> = Magnetic version

Theoretical torque at 1 bar

Ø	Torque	Max kinetic energy
	Nm	Nm
32	1,2	1,8
40	2,25	2,5
50	3,9	4,5
63	7,3	8
80	15,7	12
100	26,5	21
125	51	36

Multiply the value in the table by the operating pressure

Maximum absorbable kinetic energy

The adjustment of the rotation angle reduces the effect of the cushioning (R12 - R14)

Static loads acceptable for the pinion

Ø	Fa
	N
32	100
40	100
50	120
63	120
80	200
100	250
125	300

Fa = axial loads max (N) with Fr = 0

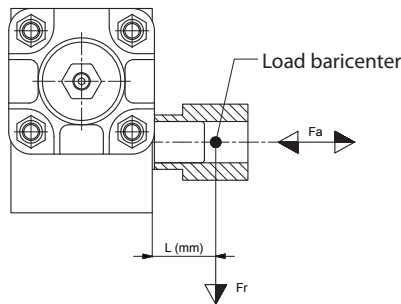

1 CYLINDERS

Radial loads max based on protrusion

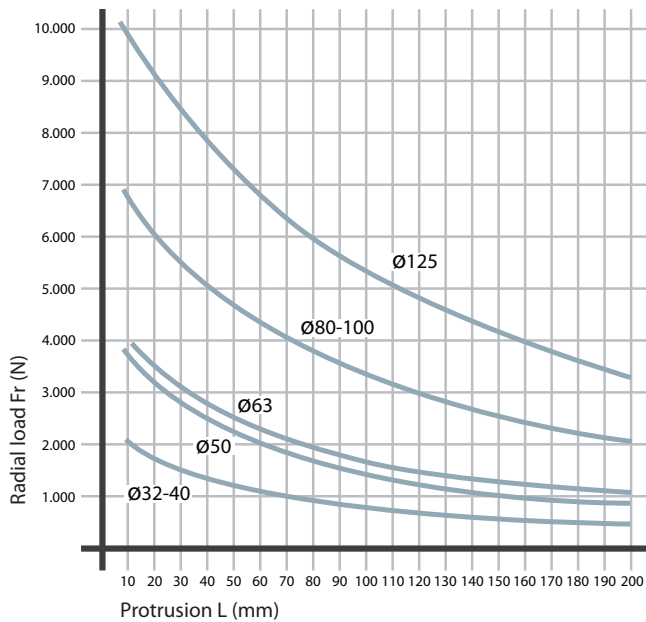

Fr = radial loads Max (N) with Fa = 0 based on L protrusion

■ Technical characteristics and accessories

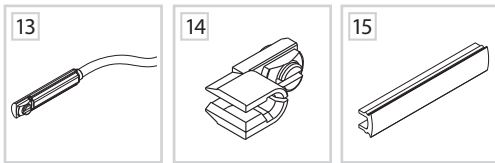
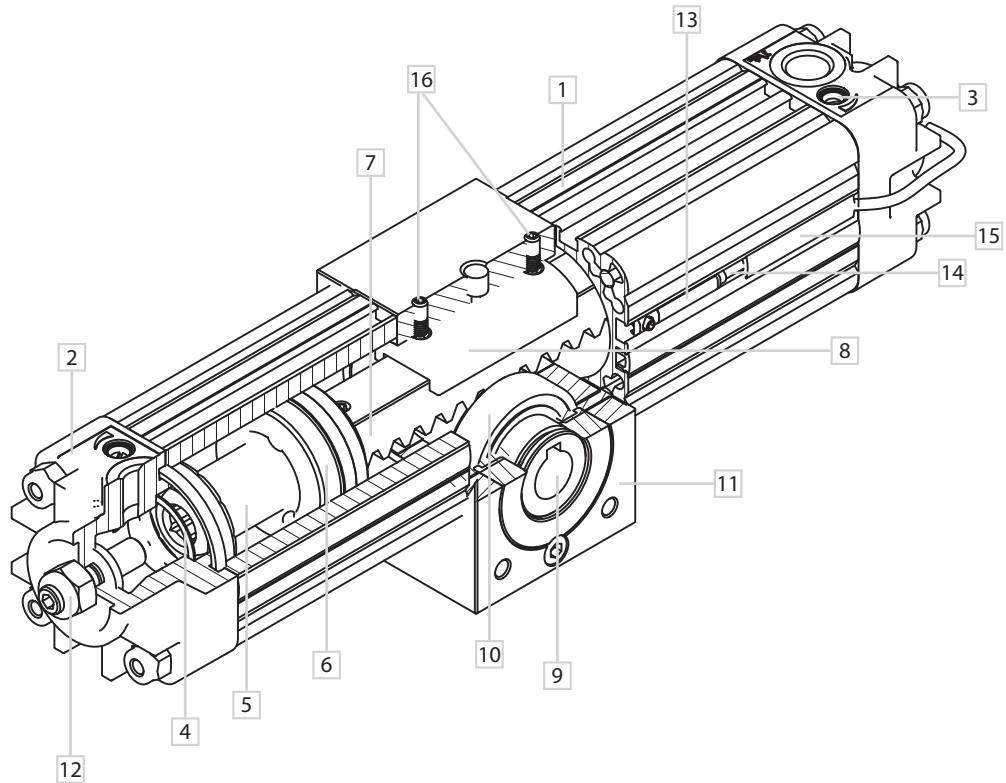

DESCRIPTION	PART NO.
1 Cylinder barrel: extruded profile in aluminium	
2 Die-cast end-caps in aluminium	
3 Pneumatic adjustable cushionings	
4 Shock absorber seals	
5 Die-cast piston in aluminium alloy and acetalic resin guide slide	
6 Piston seals in nitrile rubber compound	
7 Standards-based steel square rack	
8 Guide slide for rack (with self-adjusting backlash recovery system)	
9 Nitrided steel pinion	
10 Ball bearings for pinion support	
11 Anodized aluminum central body	
12 Adjustment screws: angle of rotation $\pm 2,5^\circ$	
13 DF magnetic sensor	DF-____
14 Cable clamping for DF sensor	DF-001
15 DHF covering strip	DHF-0020100
16 Screw for backlash recovery	

Male/female pinion with or without adjustment

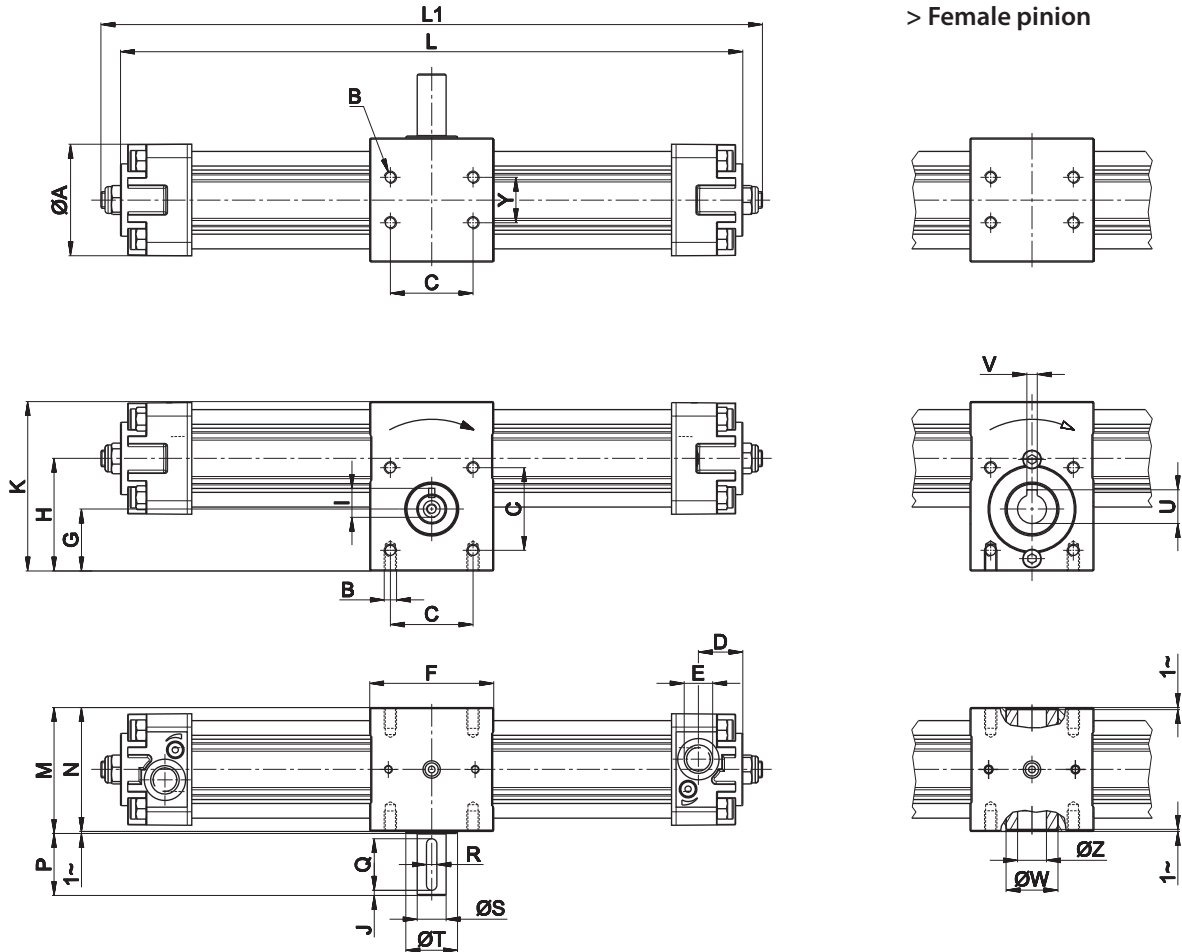

CYLINDERS 1

Ø	A	B	C	D	E	F	G	H	I	J	K	M	N	P	Q	R	S	T	U	V	W	X	Y	Z
			±0,1													H7	g 6			M7			±0,1	H7
32	48	M6	33	18	G1/8	50	25	46,5	16	2,5	71,5	51	50	30	25	5	14	25	16,3	5	25	M5	18	14
40	54	M6	40	22	G1/4	60	30	54,5	16	2,5	82	61	60	30	25	5	14	25	16,3	5	25	M5	22	14
50	67	M8	50	22	G1/4	70	32,5	60,5	21,5	2,5	94	66	65	40	35	6	19	30	21,8	6	30	M6	25	19
63	78	M8	60	25,5	G3/8	75	37	70,8	27	2,5	110	76	75	40	35	8	24	30	21,8	6	30	M8	35	19
80	97	M10	80	27	G3/8	99	50	93,5	31	2,5	142	100	99	50	45	8	28	45	27,3	8	45	M8	50	24
100	115	M10	80	27,5	G1/2	115	54	99	41	2,5	156,5	116	115	50	45	10	38	50	31,3	8	50	M10	60	28
125	140	M12	90	31,5	G1/2	125	60	118	41	2,5	188	141	140	50	45	10	38	60	31,3	8	60	M10	70	28

R = UNI 6604-A DIN 6885/A

Overall dimensions L - L1 and weights with standard rotations

Ø	Rotation 90°				Rotation 180°				Rotation 270°				Rotation 360°			
	L		Kg		L		Kg		L		Kg		L		Kg	
	L	L1	male pinion	female pinion	L	L1	male pinion	female pinion	L	L1	male pinion	female pinion	L	L1	male pinion	female pinion
32	206	234	1,300	1,200	254	282	1,420	1,320	302	330	1,540	1,440	348	378	1,660	1,560
40	246	278	2,010	1,900	304	336	2,210	2,900	360	394	2,390	2,280	418	450	2,580	2,470
50	268	308	3,070	2,840	332	372	3,340	3,110	394	436	3,610	3,380	458	498	3,880	3,650
63	310	356	4,990	4,640	386	432	5,500	5,170	460	508	6,010	5,700	536	582	6,520	6,230
80	376	426	9,840	9,220	476	526	10,840	10,230	574	626	11,840	11,240	674	726	12,840	12,250
100	404	456	13,650	12,680	512	564	14,860	13,870	618	672	16,070	15,060	726	778	17,280	16,250
125	474	520	23,370	22,220	606	654	25,720	24,520	738	786	28,070	26,820	870	918	30,420	29,120

L = overall dimensions without stroke regulation (R11 - R13)

L1 = overall dimensions with stroke regulation (R12 - R14)

Overall dimensions with intermediate rotations

Intermediate rotations can be obtained by reducing the length of the right-hand piston housing. For this purpose select the standard model having a rotation degree slightly higher than the one required. The length dimensions L-L1 are then reduced in accordance with the following table for each rotation degree.

Ø	Reduction
	mm
32	0,262
40	0,315
50	0,350
63	0,415
80	0,550
100	0,594
125	0,733

The left-hand piston housing maintains standard dimensions

$$\left( \frac{L}{2}, \frac{L_1}{2} \right)$$